

HILLTOP PLAYSET F29080

Before you begin / Antes de comenzar
Avant de commencer

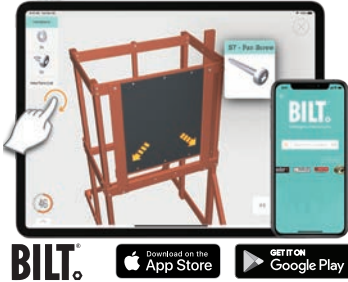

3D-GUIDED INTERACTIVE ASSEMBLY
INSTRUCTIONS CAN BE FOUND IN BILT
DOWNLOAD THE FREE APP

LAS INSTRUCCIONES DE ENSAMBLAJE INTERACTIVO
GUIADAS EN 3D SE PUEDEN ENCONTRAR EN BILT
DESCARGA LA APLICACIÓN GRATUITA

LES INSTRUCTIONS D'ASSEMBLAGE INTERACTIF
GUIDÉES EN 3D SE TROUVENT SUR BILT
TÉLÉCHARGER L'APPLICATION GRATUITE

INSTALLATION AND OPERATING INSTRUCTIONS



WARNING

To reduce the risk of serious injury or death, you must read and follow these instructions. Keep and refer to these instructions often and give them to any future owner of this play set. Manufacturer contact information provided below.

OBSTACLE FREE SAFETY ZONE - 32' 5" x 24' 4" (9.9 x 7.4 m) area requires Protective Surfacing. See page 3.

MAXIMUM VERTICAL FALL HEIGHT - 7' 8" (2.34 m)

CAPACITY - 12 Users Maximum, Ages 3 to 10; Weight Limit 110 lbs. (49.9 kg) per child.

RESIDENTIAL HOME USE ONLY. Not intended for public areas such as multi-unit residences, schools, churches, nurseries, day cares or parks.

Warning. Only for domestic use.

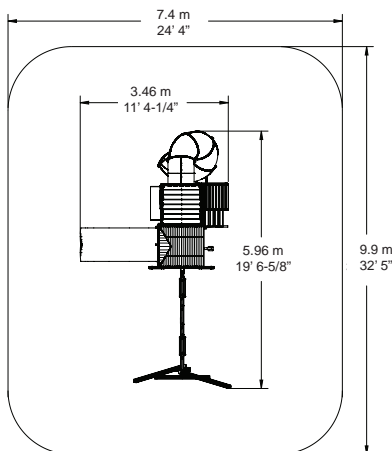

**TWO PERSON
ASSEMBLY**

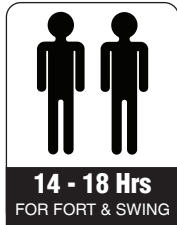

**TWO PERSON
ASSEMBLY**

Cedar Summit by KidKraft
4630 Olin Road
Dallas, TX 75244, United States

customerservice@kidkraft.com
Online Parts Replacement: parts.kidkraft.com
To warranty your product: kidkraft.com/warranty/
Customer Service:
1(800) 933-0771 or (972) 385-0100

KidKraft Netherlands BV
Olympisch Stadion 8
1076 DE Amsterdam, The Netherlands

Europe Customer Service: +31 (0)20 305 8620
europecustomerservice@kidkraft.com
EU Online Parts Replacement: parts.kidkraft.eu

Table of Contents

Warnings and Safe Play Instructions.....	pg. 2
Protective Surfacing Guidelines.....	pg. 3
Instructions for Proper Maintenance.....	pg. 4
About Our Wood – Limited Warranty.....	pg. 5
Keys to Assembly Success.....	pg. 7
Part ID.....	pg. 10
Step-By-Step Instructions.....	pg. 21
Installation of I.D./Warning Plaque.....	pg. 113

9409080

Rev 08/10/2020



Warnings and Safe Play Instructions



CONTINUOUS ADULT SUPERVISION REQUIRED. Most serious injuries and deaths on playground equipment have occurred while children were unsupervised! Our products are designed to meet mandatory and voluntary safety standards. Complying with all warnings and recommendations in these instructions will reduce the risk of serious or fatal injury to children using this play system. Go over the warnings and safe play instructions regularly with your children and make certain that they understand and follow them. Remember on-site adult supervision is required for children of all ages.



WARNING

SERIOUS HEAD INJURY HAZARD

Installation over concrete, asphalt, dirt, grass, carpet and other hard surface creates a risk of serious injury or death from falls to the ground. Install and maintain shock absorbing material under and around play-set as recommended on page 3 of these instructions.

COLLISION HAZARD

Place play-set on level ground at least 2m from any obstruction such as a garage or house, fences, poles, trees, sidewalks, walls, landscape timbers, rocks, pavement, planters, garden borders, overhanging branches, laundry lines, and electrical wires. (See OBSTACLE FREE SAFETY ZONE on cover)

CHOKING HAZARD/SHARP EDGES & POINTS

Adult assembly required. This product contains small parts and parts with sharp edges and points. Keep parts away from children until fully assembled.

WARNING LABEL

Owners shall be responsible for maintaining the legibility of the warning labels.

STRANGULATION HAZARD

- NEVER allow children to play with ropes, clotheslines, pet leashes, cables, chains or cord-like items when using this play-set or to attach these items to play-set.
- NEVER allow children to wear loose fitting clothing, ponchos, hoods, scarves, capes, necklaces, items with draw-strings, cords or ties when using this play-set.
- NEVER allow children to wear bike or sport helmets when using this play-set.

Failure to prohibit these items, even helmets with chin straps, increases the risk of serious injury and death to children from entanglement and strangulation.

TIP OVER HAZARD

Choose a level location for the equipment. This can reduce the likelihood of the play set tipping over and loose-fill surfacing materials washing away during heavy rains.

DO NOT allow children to play on the play-set until the assembly is complete and the unit is properly anchored.

Never add extra length to chain or rope. The chains or ropes provided are the maximum length designed for the swinging element(s).



WARNING – Safe Play Instructions

- ✓ Observe capacity limitations of your play-set. See front cover.
- ✓ Dress children with well fitting and full foot enclosing footwear.
- ✓ Teach children to sit with their full weight in the center of the swing seat to prevent erratic swing motion or falling off.
- ✓ Check for splintered, broken or cracked wood; missing, loose, or sharp edged hardware. Replace, tighten and or sand smooth as required prior to playing.
- ✓ Verify that suspended climbing ropes, rope ladders, chain or cable are secured at both ends and cannot be looped back on itself as to create an entanglement hazard.
- ✓ On sunny and or hot days, check the slide and other plastic rides to assure that they are not very hot as to cause burns. Cool hot slide and rides with water and wipe dry prior to using.
- ✓ Orientate slide such that it gets the least amount of exposure to the sun.
- ✗ Do not allow children to wear open toe or heel footwear like sandals, flip-flops or clogs.
- ✗ Do not allow children to walk, in front, between, behind or close to moving rides.
- ✗ Do not let children twist swing chains or ropes or loop them over the top support bar. This may reduce the strength of the chain or rope and cause premature failure.
- ✗ Do not let children get off rides while they are in motion.
- ✗ Do not permit climbing on equipment when it is wet.
- ✗ Do not permit rough play or use of equipment in a manner for which it was not intended. Standing on or jumping from the roof, elevated platforms, swings, climbers, ladders or slide can be dangerous.
- ✗ Do not allow children to swing empty rides or seats.
- ✗ Do not allow children to go down slide head first or run up slide.

Protective Surfacing - Reducing Risk of Serious Head Injury From Falls

One of the most important things you can do to reduce the likelihood of serious head injuries is to install shock-absorbing protective surfacing under and around your play equipment. The protective surfacing should be applied to a depth that is suitable for the equipment height in accordance with ASTM F1292. There are different types of surfacing to choose from; whichever product you select, follow these guidelines:

Loose-Fill Materials

- Maintain a minimum depth of 9 inches (23 cm) of loose-fill materials such as wood mulch/chips, engineered wood fiber (EWF), or shredded/recycled rubber mulch for equipment up to 8 feet (2,45 m) high; and 9 inches (23 cm) of sand or pea gravel for equipment up to 5 feet (1,5 m) high. NOTE: An initial fill level of 12 inches (31 cm) will compress to about a 9-inch (23 cm) depth of surfacing over time. The surfacing will also compact, displace, and settle, and should be periodically raked and refilled to maintain at least a 9-inch (23 cm) depth.
- Use a minimum of 6 inches (16 cm) of protective surfacing for play equipment less than 4 feet (1,22 m) in height. If maintained properly, this should be adequate. (At depths less than 6 inches (16 cm), the protective material is too easily displaced or compacted.)

NOTE: Do not install home playground equipment over concrete, asphalt, or any other hard surface. A fall onto a hard surface can result in serious injury to the equipment user. Grass and dirt are not considered protective surfacing because wear and environmental factors can reduce their shock absorbing effectiveness. Carpeting and thin mats are not adequate protective surfacing. Ground level equipment -- such as a sandbox, activity wall, playhouse or other equipment that has no elevated play surface -- does not need any protective surfacing.

- Use containment, such as digging out around the perimeter and/or lining the perimeter with landscape edging. Don't forget to account for water drainage.
- Periodically rake, check and maintain the depth of the loose-fill surfacing material. Marking the correct depth on the play equipment support posts will help you to see when the material has settled and needs to be raked and or replenished. Be sure to rake and evenly redistribute the surfacing in heavily used areas.
- Do not install loose fill surfacing over hard surfaces such as concrete or asphalt.

Poured-In-Place Surfaces or Pre-Manufactured Rubber Tiles

You may be interested in using surfacing other than loose-fill materials - like rubber tiles or poured-in-place surfaces.

- Installations of these surfaces generally require a professional and are not "do-it yourself" projects.
- Review surface specifications before purchasing this type of surfacing. Ask the installer/manufacturer for a report showing that the product has been tested to the following safety standard: ASTM F1292 *Standard Specification for Impact Attenuation of Surfacing Materials within the Use Zone of Playground Equipment*. This report should show the specific height for which the surface is intended to protect against serious head injury. This height should be equal to or greater than the fall height - vertical distance between a designated play surface (*elevated surface for standing, sitting, or climbing*) and the protective surfacing below - of your play equipment.
- Check the protective surfacing frequently for wear.

Placement

Proper placement and maintenance of protective surfacing is essential. Refer to diagram on front cover. Be sure to;

- Extend surfacing at least 6 feet (1,8 m) from the equipment in all directions.
- For to-fro swings, extend protective surfacing in front of and behind the swing to a distance equal to twice the height of the top bar from which the swing is suspended.
- For tire swings, extend surfacing in a circle whose radius is equal to the height of the suspending chain or rope, plus 6 feet (1,8 m) in all directions.

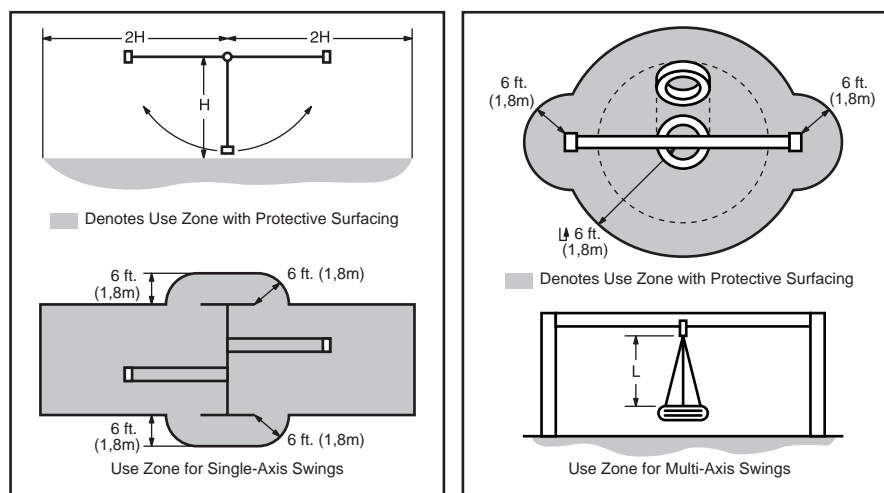

Instructions for Proper Maintenance

Your KidKraft Play System is designed and constructed of quality materials with your child's safety in mind. As with all outdoor products used by children, it will weather and wear. To maximize the enjoyment, safety and life of your Play Set, it is important that you, the owner, properly maintain it.

Check the following at the beginning of the play season:

HARDWARE:

- ✓ Check metal parts for rust. If found, sand and repaint using a non-lead paint complying with 16 CFR 1303.
- ✓ Inspect and tighten all hardware. On wood assemblies **DO NOT OVER-TIGHTEN** as to cause crushing and splintering of wood.
- ✓ Check for sharp edges or protruding screw threads, add washers if required.

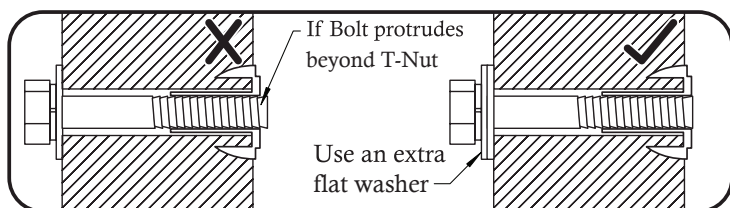
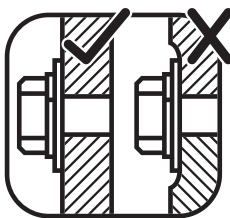

SHOCK ABSORBING SURFACING:

- ✓ Check for foreign objects. Rake and check depth of loose fill protective surfacing materials to prevent compaction and maintain appropriate depth. Replace as necessary. (See Protective Surfacing, page 3)

GROUND STAKES (ANCHORS):

- ✓ Check for looseness, damage or deterioration. Should firmly anchor unit to ground during use. Re-secure and or replace, if necessary.

SWING HANGERS:

- ✓ Check that bolts are secure and tight. Quick clips should be completely closed and threaded clips screwed tight.

- ✓ If squeaking occurs lubricate bushings with oil or WD-40®.

SWINGS, ROPES AND RIDES:

- ✓ Reinstall if removed during cold season. Check all moving parts including swing seats, ropes, chains and attachments for wear, rust and other deterioration. Replace as needed.
- ✓ Check that ropes are tight, secure at both ends and cannot loop back as to create an entrapment.

WOOD PARTS:

- ✓ Check all wood members for deterioration, structural damage and splintering. Sand down splinters and replace deteriorated wood members. As with all wood, some checking and small cracks in grain is normal.
- ✓ Applying a water repellent or stain (water-based) on a yearly basis is important maintenance to maintain maximum life and performance of the product.

Check twice a month during play season:

HARDWARE:

- ✓ Inspect for tightness. Must be firmly against, but not crushing the wood. **DO NOT OVER-TIGHTEN.** This will cause splintering of wood.
- ✓ Check for sharp edges or protruding screw threads. Add washers if required.

SHOCK ABSORBING SURFACING:

- ✓ Rake and check depth of loose fill protective surfacing materials to prevent compaction and maintain appropriate depth. Replace as necessary. (See Protective Surfacing, page 3)

Check once a month during play season:

SWING HANGERS:

- ✓ Check that they are secure and orientated correctly. Hook should rotate freely and perpendicular to support beam.
- ✓ If squeaking occurs lubricate bushings with oil or WD-40®.

SWINGS AND RIDES:

- ✓ Check swing seats, all ropes, chains and attachments for fraying, wear, excessive corrosion or damage. Replace if structurally damaged or deteriorated.

Check at the end of the play season:

SWINGS AND RIDES:

- ✓ To prolong their life, remove swings and store inside when outside temperature is below 32°F/0°C. Below freezing, plastic parts may become more brittle.

SHOCK ABSORBING SURFACING:

- ✓ Rake and check depth of loose fill protective surfacing materials to prevent compaction and maintain appropriate depth. Replace as necessary. (See Protective Surfacing, page 3)

If you dispose of your play set: Please disassemble and dispose of your unit so that it does not create any unreasonable hazards at the time it is discarded. Be sure to follow your local waste ordinances.

About Our Wood

KidKraft Premium Play Systems uses only premium playset lumber, ensuring the safest product for your children's use. Although we take great care in selecting the best quality lumber available, wood is still a product of nature and susceptible to weathering which can change the appearance of your set.

What causes weathering? Does it affect the strength of my Play System?

One of the main reasons for weathering is the effects of water (moisture); the moisture content of the wood at the surface is different than the interior of the wood. As the climate changes, moisture moves in or out of the wood, causing tension which can result in checking and or warping. You can expect the following due to weathering. These changes will not affect the strength of the product:

1. **Checking** is surface cracks in the wood along the grain. A post (4" x 4") will experience more checking than a board (1" x 4") because the surface and interior moisture content will vary more widely than in thinner wood.
2. **Warping** results from any distortion (twisting, cupping) from the original plane of the board and often happens from rapid wetting and drying of the wood.
3. **Fading** happens as a natural change in the wood color as it is exposed to sun-light and will turn a grey over time.

How can I reduce the amount of weathering to my Play System?

At the factory we have coated the wood with a water repellent or stain. This coating decreases the amount of water absorption during rain or snow thus decreasing the tension in the wood. Sunlight will break down the coating, so we recommend applying a water repellent or stain on a yearly basis (see your local stain and paint supplier for a recommended product).

Most weathering is just the normal result of nature and will not affect safe play and enjoyment for your child. However if you are concerned that a part has experienced a severe weathering problem please call our consumer relations department for further assistance.

Complete and mail registration card to receive important product notifications and assure prompt warranty service.

KidKraft Limited Warranty

MISSING OR DAMAGED PARTS:

KidKraft will replace any parts within 90 days from date of purchase found to be missing from or damaged in the original packaging. See Fig.1

Fig. 1	<u>Product Age (All Parts)</u> 0-90 Days from date of purchase	<u>Consumer Pays</u> \$0 for Part + Free Shipping
--------	---	--

DEFECTS IN MATERIAL AND WORKMANSHIP:

KidKraft warrants that this product is free from defects in materials and workmanship for a period of one (1) year from the original date of purchase (dated sales receipt and/or product registration is required). This one (1) year warranty covers all parts including wood, hardware, and all accessories (Such as swings, rides, and slides). See Fig. 2

Fig. 2	<u>Product Age (All Parts)</u> 91 Days to 1 Year	<u>Consumer Pays</u> \$0 for Part + Free Shipping
--------	---	--

WOOD ROT, DECAY, AND INSECT DAMAGE:

All wood carries a five (5) year warranty against rot, decay, and insect damage (dated sales receipt and/or product registration is required). Refer to the schedule below for charges associated with replacement of wood parts under this **Limited Warranty**. See Fig. 3

Fig. 3	<u>Product Age (Wood Parts)</u> 0 Days to 1 Year After 1 Year to 5 Year Over 5 Years	<u>Consumer Pays</u> \$0 for Part + Free Shipping \$0 for Part + Shipping & Handling 100% for Part (if available) + Shipping & Handling
--------	---	--

This warranty applies to the original owner and registrant and is non-transferable. Regular maintenance is required to ensure the integrity of this product. Failure by the owner to maintain the product according to the maintenance requirements may void this warranty.

This Limited Warranty does NOT cover:

- Any inspection cost
- Labor and/or costs for replacement of any defective item(s), including but not limited to, professional installer costs
- Incidental or consequential damages, including but not limited to, as a result of set relocation, move and/or reinstall
- Cosmetic defects which do not affect performance or integrity of a part or the entire product
- Vandalism, improper use or installation, or acts of nature, including but not limited to, high winds, fire, and flood
- Minor twisting, warping, checking, or any natural occurring properties of wood that do not affect performance or integrity.
- Any KidKraft product purchased, including but not limited to, a non-approved retailer, auction houses, second-hand, and as-is clearance items.

KidKraft products have been designed for safety and quality. Modifications made to the original product may damage the structural integrity of the unit leading to failure and possible injury. KidKraft cannot assume any responsibility for the modified products. Furthermore, modifications void all warranties.

This product is warranted for **RESIDENTIAL USE ONLY**. Under no circumstance should a KidKraft product be used in public settings such as schools, churches, playgrounds, parks, home and professional day cares and the like. Such use may lead to product failure and potential injury. Public use will void this warranty. KidKraft disclaims all other representations and warranties of any kind, express or implied.

Keys to Assembly Success

Tools Required

<ul style="list-style-type: none"> • Tape Measure • Carpenters Level • Carpenters Square • Claw Hammer • Standard or Cordless Drill • Rubber Mallet 	<ul style="list-style-type: none"> • #1 Phillips, #2 Robertson and Screwdriver • Ratchet with extension (1/2" & 9/16" sockets) 	<ul style="list-style-type: none"> • Open End Wrench (1/2" & 9/16") • Adjustable Wrench • 1/8" & 3/16" Drill Bits 	<ul style="list-style-type: none"> • 3/16" Hex Key • 8' Step Ladder • Safety Glasses • Adult Helpers • Pencil
---	--	--	--





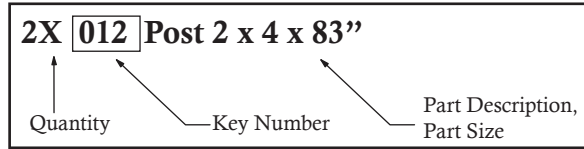

Part Identification Key

On each page, you will find the parts and quantities required to complete the assembly step illustrated on that page. Here is a sample.



Symbols

Throughout these instructions symbols are provided as important reminders for proper and safe assembly.

<p>This identifies information that requires special attention. Improper assembly could lead to an unsafe or dangerous condition.</p> 	<p>Check that set or assembly is properly level before proceeding.</p> <p>Use Level</p> 
<p>Use Help</p>  <p>Use Help</p>  <p>Where this is shown, 2 or 3 people are required to safely complete the step. To avoid injury or damage to the assembly make sure to get help!</p>	<p>Pre-drill 1/8" & 3/16" Bit</p> <p>Pre-drill a pilot hole before fastening screw or lag to prevent splitting of wood.</p>
<p>Measure Distance</p>  <p>Check that assembly is square before tightening bolts.</p> <p>Square Assembly</p> 	<p>Tighten Bolts</p>  <p>This indicates time to tighten bolts, but not too tight! Do not crush the wood. This may create splinters and cause structural damage.</p>

CAUTION – Protrusion Hazard

Once the assembly is tightened, watch for exposed threads. If a thread protrudes from the T-Nut, remove the bolt and add washers to eliminate this condition. Extra washers have been provided for this purpose.

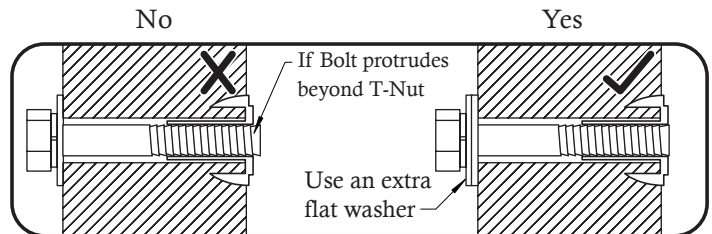

Proper Hardware Assembly

Lag screws require drilling pilot holes to avoid splitting wood. Only a flat washer is required. For ease of installation liquid soap can be used on all lag-type screws.

For bolts, tap T-Nut into hole with hammer. Insert the hex bolt through lock washer first then flat washer then hole. Because the assemblies need to be squared do not completely tighten until instructed. Pay close attention to diameter of the bolts. 5/16" is slightly larger than 1/4".

Note: Wafer head bolts with blue lock tight or a bolt with a Ny-Lok nut do NOT require a lock washer.

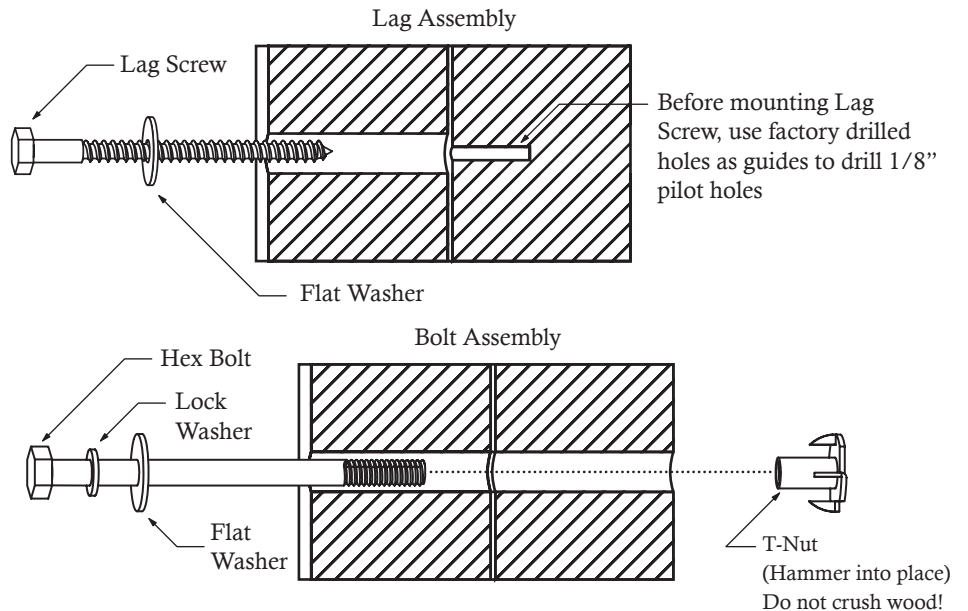

BACK

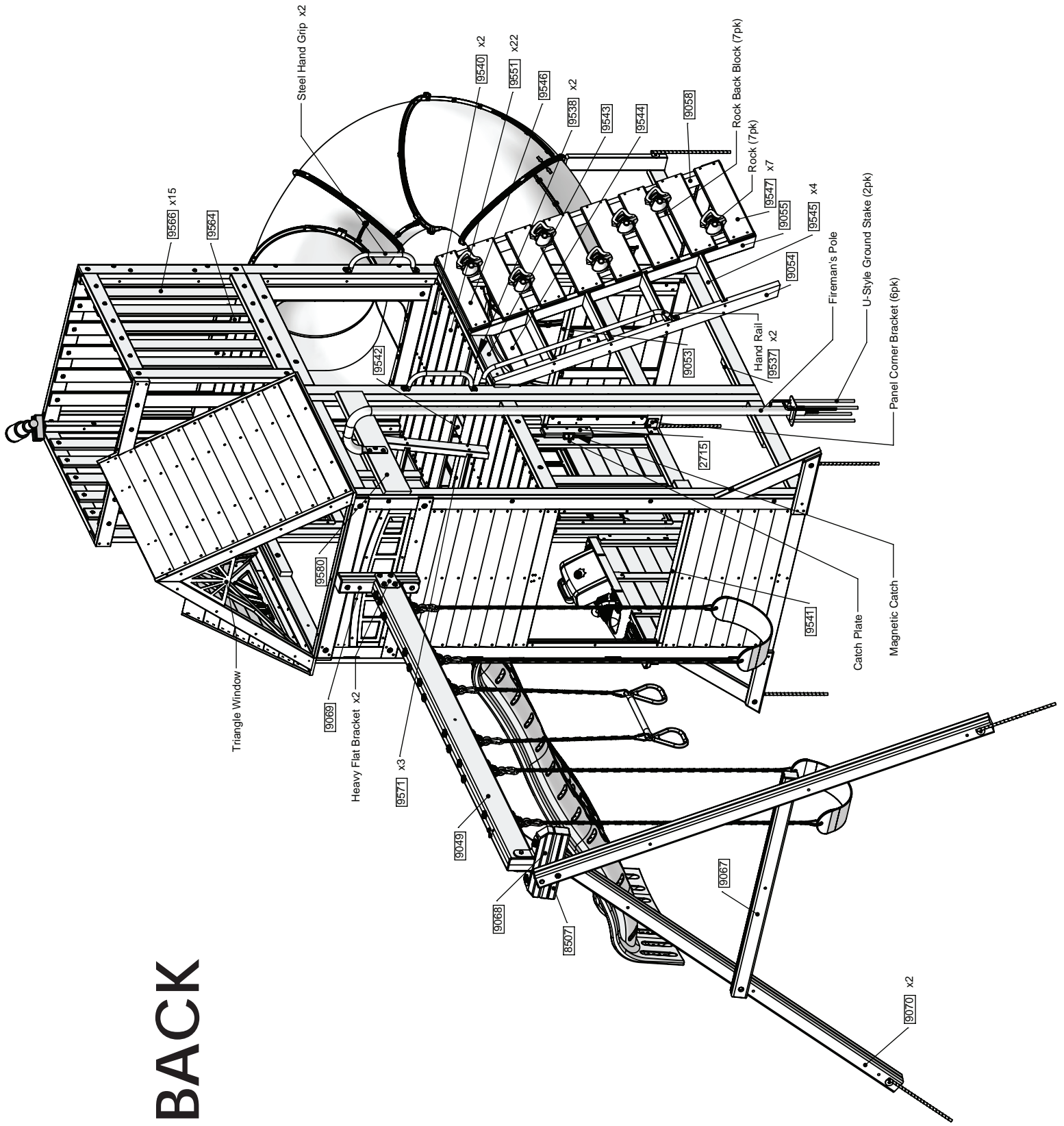

Part Identification (Reduced Part Size)

2pc. - **2606** - 23.8 x 82.6 x 362 - SW Ground FSC - Box 3 - 4812606

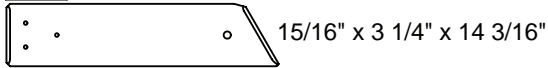

2pc. - **2607** - 31.8 x 76.2 x 558.8 - Diagonal FSC - Box 3 - 4812607

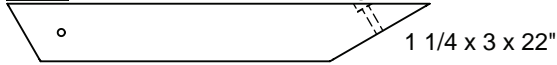

2pc. - **9537** - 31.8 x 76.2 x 714.8 - Floor Joist FSC - Box 3 - 4819537



2pc. - **9538** - 31.8 x 31.8 x 1902.0 - Side Joist FSC - Box 1 - 4819538

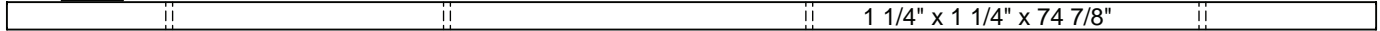

1pc. - **2611** - 23.8 x 108 x 1006.5 - Table Top FSC - Box 2 - 4812611



1pc. - **9539** - 31.8 x 31.8 x 1006.5 - Table Support FSC - Box 3 - 4819539

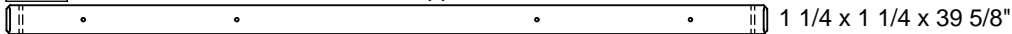

2pc. - **9540** - 15.9 x 82.6 x 904.9 - Floor Board FSC - Box 2 - 4819540

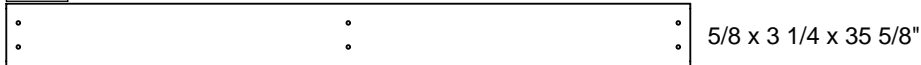

22pc. - **9051** - 15.9 x 114.3 x 904.9 - Floor Board FSC - Box 2 - 4819051



1pc. - **9541** - 23.8 x 57.2 x 813 - End Wall Top FSC - Box 2 - 4819541

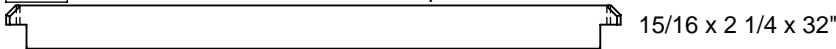

1pc. - **9542** - 31.8 x 76.2 x 1906 - Long Floor Joist FSC - Box 2 - 4819542



1pc. - **9058** - 34.9 x 63.5 x 1468.8 - Rope Rail FSC - Box 1 - 4609058

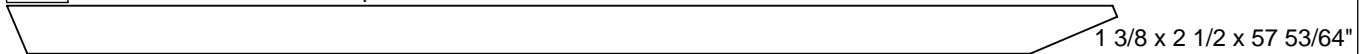

1pc. - **9054** - 34.9 x 63.5 x 1468.8 - Left Access FSC - Box 1 - 4609054

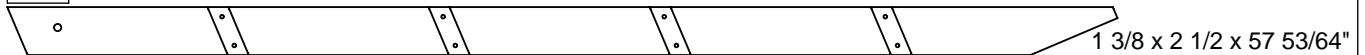

1pc. - **9055** - 34.9 x 63.5 x 1468.8 - Right Access FSC - Box 1 - 4609055

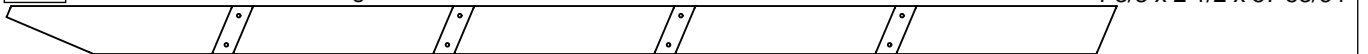

1pc. - **9543** - 15.9 x 82.6 x 1033.5 - Support Top FSC - Box 3 - 4609543

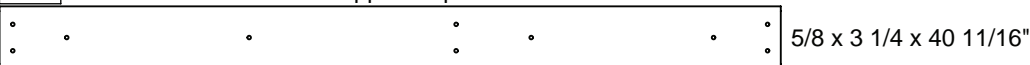

1pc. - **9544** - 15.9 x 82.6 x 449.3 - Short Support FSC - Box 3 - 4609544

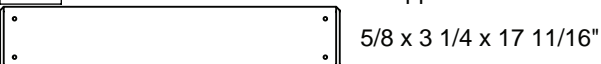

4pc. - **9545** - 23.8 x 82.6 x 411.2 - Tread FSC - Box 3 - 4609545



Part Identification (Reduced Part Size)

1pc. - **9546** - 15.9 x 101.6 x 617 - Access Board Top FSC - Box 3 - 4609546

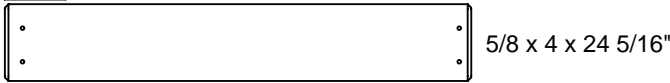

7pc. - **9547** - 15.9 x 133.4 x 617 - Access Board FSC - Box 3 - 4609547



1pc. - **9548** - 23.8 x 82.6 x 704.9 - Ground Brace FSC - Box 3 - 4819548



1pc. - **9549** - 15.9 x 101.6 x 1016 - Roof Base FSC - Box 3 - 4819549

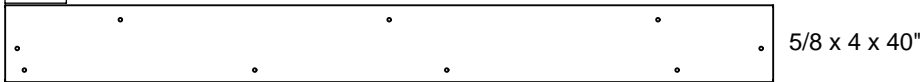

1pc. - **9550** - 15.9 x 31.8 x 906.1 - Narrow Roof Base FSC - Box 3 - 4819550



2pc. - **9551** - 31.8 x 63.5 x 1047.7 - Roof Support Left FSC - Box 2 - 4609551

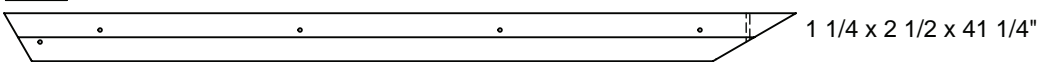

2pc. - **9552** - 31.8 x 63.5 x 1047.7 - Roof Support Right FSC - Box 2 - 4609552

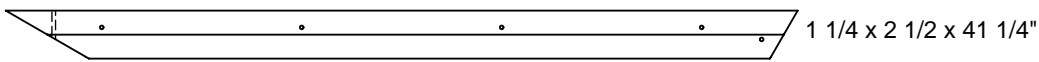

2pc. - **9553** - 38.1 x 38.1 x 1828.8 - Support FSC - Box 1 - 4819553 1 1/2 x 1 1/2 x 72"

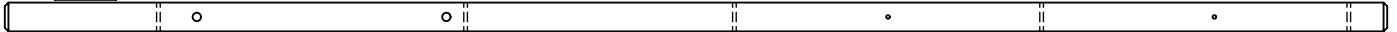

1pc. - **9554** - 15.9 x 69.9 x 1016 - Roof Base Narrow FSC - Box 3 - 4819554

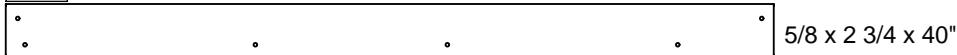

4pc. - **9555** - 31.8 x 76.2 x 954.3 - Bottom Fence FSC - Box 2 - 4819555

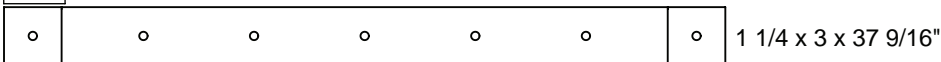

4pc. - **9556** - 31.8 x 76.2 x 838.2 - Fence Post FSC - Box 3 - 4819556

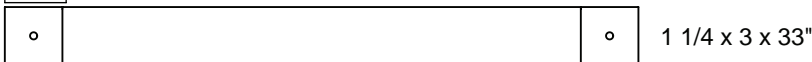

2pc. - **9557** - 31.8 x 76.2 x 838.2 - Fence Post A FSC - Box 3 - 4819557

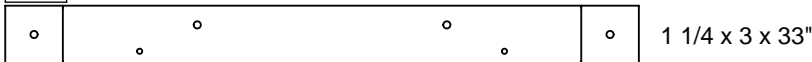

2pc. - **9558** - 31.8 x 76.2 x 908 - Fence Bottom Narrow FSC - Box 2 - 4819558

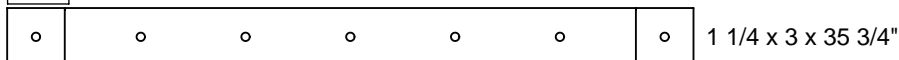

Part Identification (Reduced Part Size)

2pc. - **9559** - 31.8 x 76.2 x 436.7 - Roof Tie FSC - Box 3 - 4819559

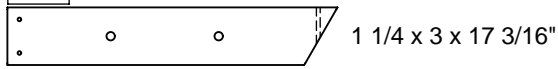

1pc. - **9560** - 25.4 x 60.3 x 1213 - Terrace Support Left FSC - Box 3 - 4819560

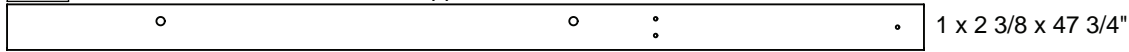

1pc. - **9561** - 25.4 x 60.3 x 1213 - Terrace Support Right FSC - Box 3 - 4819561



1pc. - **9562** - 25.4 x 60.3 x 855.3 - Mid Joist FSC - Box 3 - 4819562

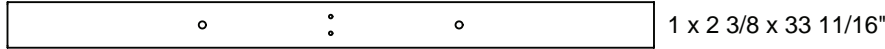

1pc. - **9563** - 25.4 x 60.3 x 881.1 - Deck Floor Support FSC - Box 3 - 4819563

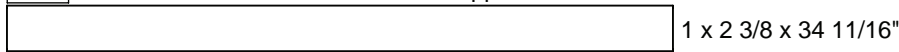

1pc. - **9564** - 15.9 x 101.6 x 904.9 - Terrace Floor Board FSC - Box 2 - 4819564

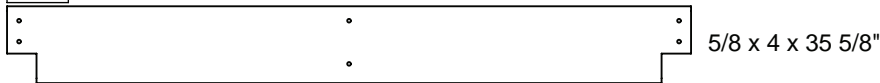

1pc. - **9565** - 31.8 x 31.8 x 891.3 - Skylight Bottom FSC - Box 3 - 4609565

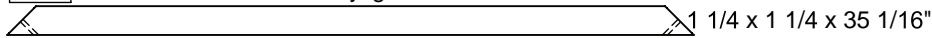

15pc. - **9566** - 15.9 x 76.2 x 838.2 - Fence Board FSC - Box 2 - 4819566

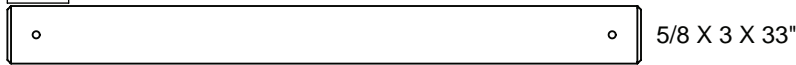

2pc. - **9567** - 15.9 x 76.2 x 464.1 - Fence Board Long A FSC - Box 3 - 4819567



2pc. - **9568** - 15.9 x 76.2 x 914.4 - Fence Board Long B FSC - Box 2 - 4819568

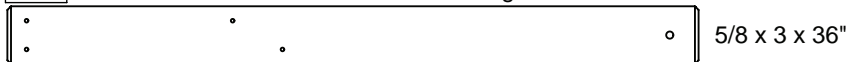

1pc. - **9569** - 34.9 x 63.5 x 1011 - Nest Right Access FSC - Box 1- 4609569

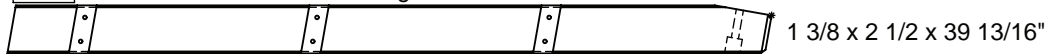

1pc. - **9570** - 34.9 x 63.5 x 1011 - Nest Left Access FSC - Box 1- 4609570

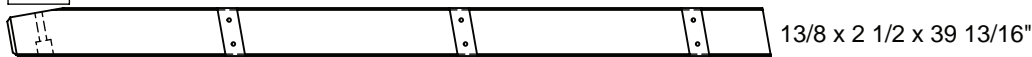

3pc. - **9571** - 23.8 x 82.6 x 343 - Nest Tread FSC - Box 2 - 4609571

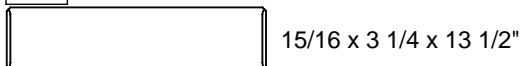

1pc. - **9572** - 15.9 x 76.2 x 374.6 - Stop Behind FSC - Box 3 - 4609572



Part Identification (Reduced Part Size)

1pc. - **9573** - 31.8 x 76.2 x 783.4 - Slide Bottom FSC - Box 3 - 4819573



1pc. - **9574** - 31.8 x 127 x 785.4 - Slide Top FSC - Box 2 - 4819574



2pc. - **9575** - 31.8 x 82.6 x 914.4 - Slide Post FSC - Box 3 - 4819575



1pc. - **9576** - 31.8 x 76.2 x 353.6 - Gusset FSC - Box 2 - 4819576



1pc. - **9680** - 31.8 x 76.2 x 489 - TNR Upright FSC - Box 3 - 4819680

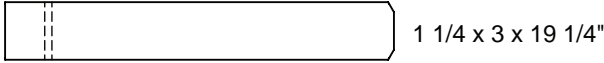

1pc. - **9577** - 31.8 x 76.2 x 630 - TNR Ground Brace FSC - Box 3 - 4819577



1pc. - **9578** - 15.9 x 76.2 x 332.1 - Roof Pull FSC - Box 3 - 4819578

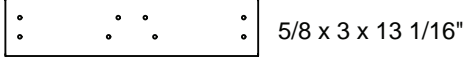

1pc. - **9579** - 15.9 x 50.8 x 557.1 - Playroom Bottom FSC - Box 3 - 4819579

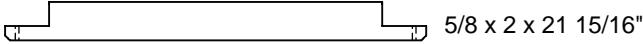

1pc. - **9580** - 31.8 x 133.4 x 846.3 - Pipe Top FSC - Box 2 - 4819580



1pc. - **9049** - 31.8 x 133.4 x 2336.8 - Engineered SW Beam - Box 1 - 4819049

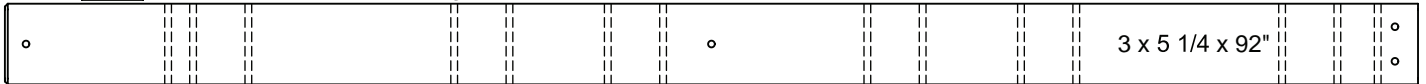

1pc. - **9067** - 63.5 x 76.2 x 1295.4 - Support Cross - Box 1 - 4819067

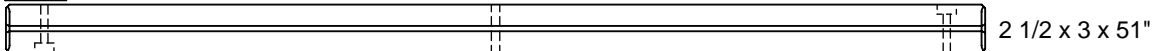

1pc. - **9068** - 63.5 x 76.2 x 381 - SW Block Angle - Box 3 - 4819068

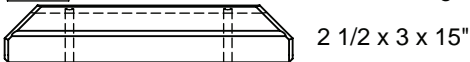

1pc. - **8507** - 63.5 x 76.2 x 381 - SW Block Angle FSC - Box 3 - 4818507

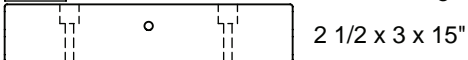

Part Identification (Reduced Part Size)

2pc. - [9070] - 76.2 x 76.2 x 2336.8 - Swing Post - Box 1 - 4819070



1pc. - [9069] - 76.2 x 76.2 x 406.4 - SW Mount - Box 3 - 4819069

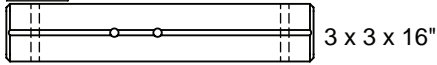

1pc. - [2715] - 25.4 x 63.5 x 254 - Door Stop FSC - Box 3 - 4812715



1pc. - [9581] - 31.8 x 76.2 x 939.8 - Cross Frame FSC - Box 3 - 4819581

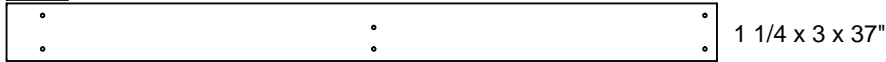

1pc. - [9276] - 31.8 x 971.6 x 1036.6
Back Roof FSC - Box 2 - 47609276
1 1/4 x 38 1/4 x 40 13/16\"

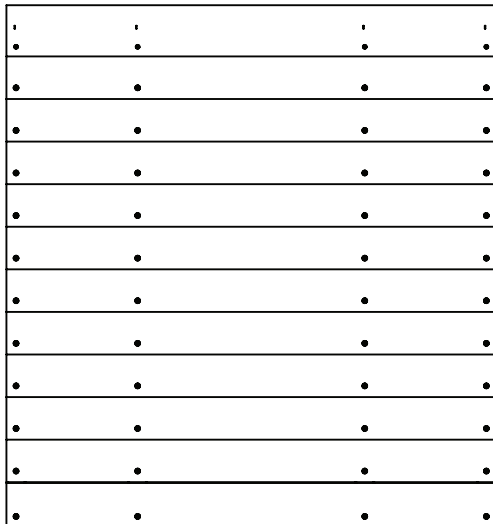

1pc. - [9277] - 31.8 x 971.6 x 1036.5
Front Roof FSC - Box 2 - 47609277
1 1/4 X 38 1/4 X 40 13/16\"

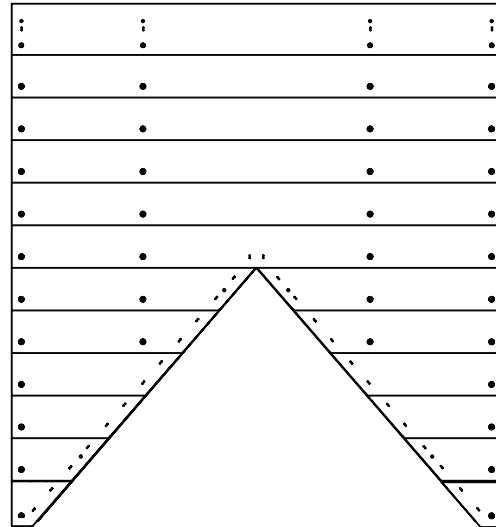

1pc. - [9279] - 38.1 x 316.5 x 718.4
Housetop Skylight Right FSC - Box 2 - 47609279
1 1/8 x 12 7/16 x 28 5/16\"

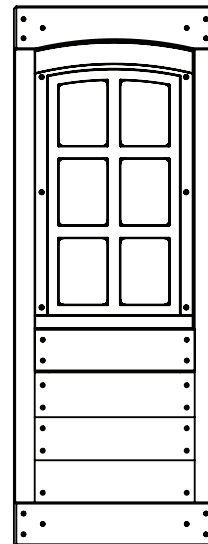
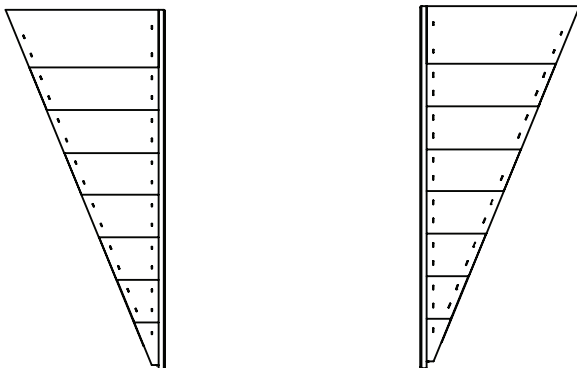

1pc. - [2837] - 38.1 x 400.1 x 1070
Door Window Panel - Box 3 - 47602837
1 1/4 x 15 3/4 x 42 1/8\"

1pc. - [9278] - 38.1 x 316.5 x 718.4
Housetop Skylight Left FSC - Box 2 - 47609278
1 1/8 x 12 7/16 x 28 5/16\"

Part Identification (Reduced Part Size)

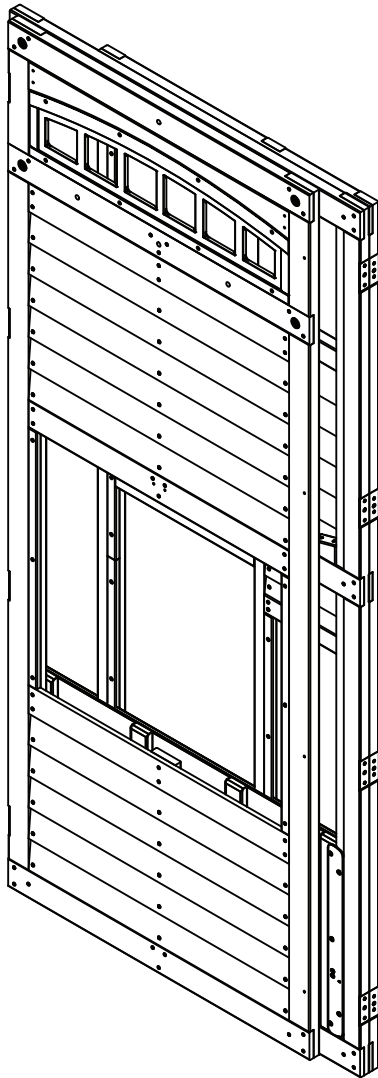

1pc. - **9286** - 90.2 x 1092.2 x 2336.8
 Front Panel Assembly FSC - Box 3 - 47819286
 3-1/2 x 43 x 92"

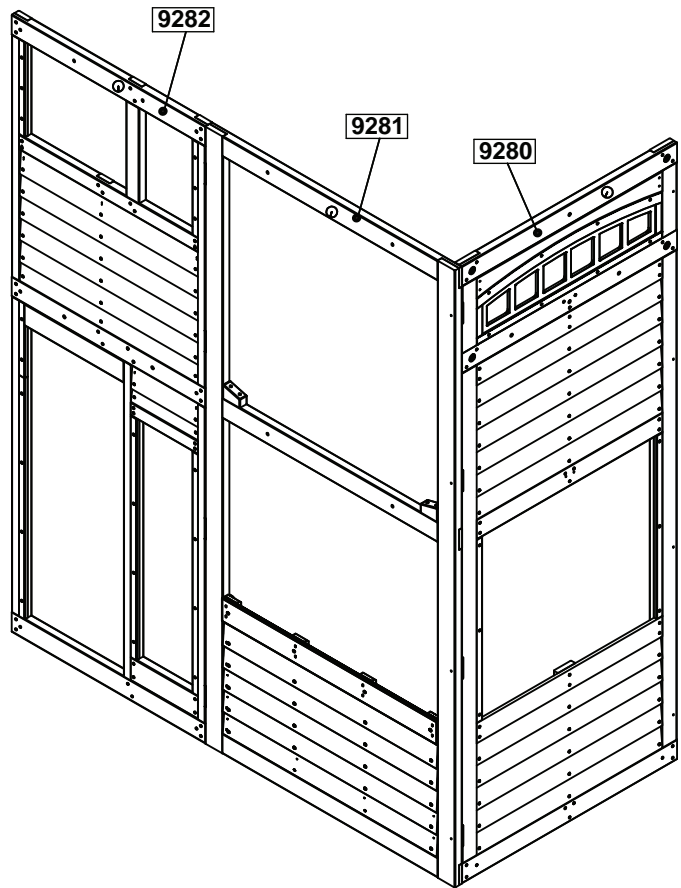

**If you need to order parts,
 please order below part #**

9280 - SW Wall Panel - 1pc - 47819280

9281 - Panel Front Wall -1pc - 47819281

9282 - Door Wall -1pc - 47819282

9325984 - Playset Hinge - 1pc

(S0) - 52933505 - Truss Screw #8 x 7/8" - 1pc.



(S0) - 52933505

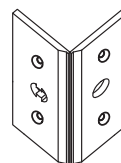

9325984

Part Identification (Reduced Part Size)

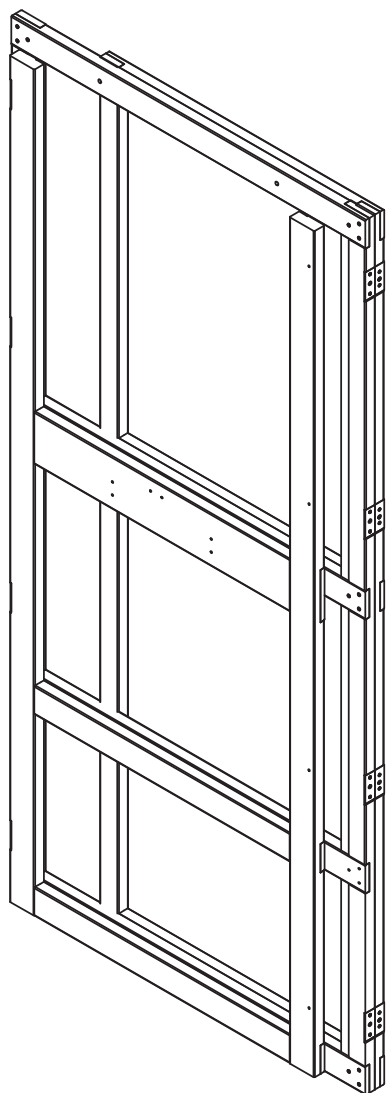

1pc. - **9287** - 90.2 x 1092.2 x 2336.8
Back Panel Assembly FSC - Box 2 - 47819287
3-1/2 x 43 x 92"

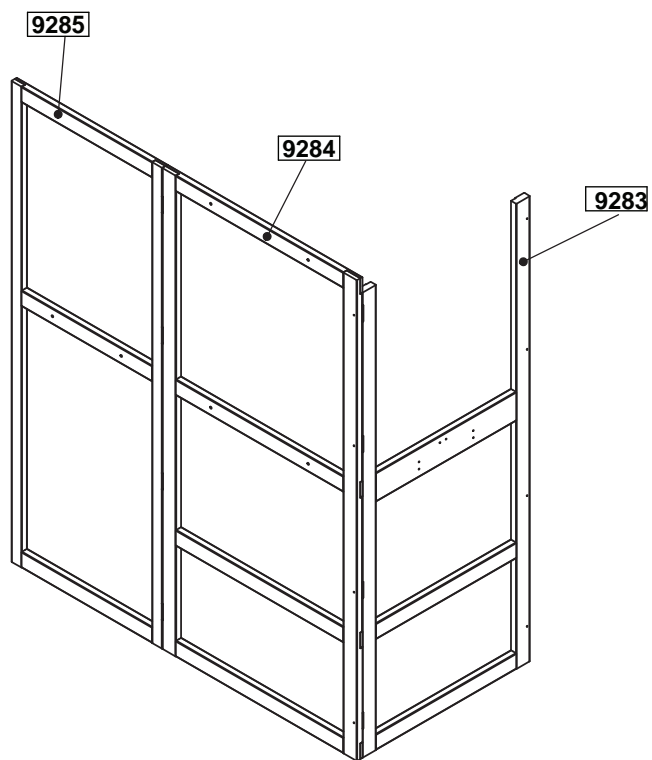

**If you need to order parts,
please order below part #**

9283 - Slide End Panel - 1pc - 47819283

9284 - Back Wall -1pc - 47819284

9285 - Narrow Back Wall -1pc - 47819285

9325984 - Playset Hinge - 1pc

S0 - 52933505 - Truss Screw #8 x 7/8" - 1pc.



S0 - 52933505

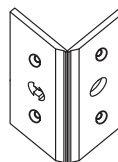

9325984

Part Identification (Reduced Part Size)

1x - Quadrex Driver
(9200015)

1x - Kidkraft
3L ID Plaque
(9320374)

1x - Rock Back
Block (7 Pk)
1pc. - (9330026)

1x - Rocks (7 Pk)
(3329080)
Green(9320082LG)/
Blue(9320082BL)/
Yellow(9320082YL)/
Poppy(9320082RD)

1x - TNR3 Extend Flange Rt
(3310131) (Green)

1x - Cedar Summit Plaque
(9320358)

1x - 1/8" Drill Bit
(9300183)

1x - TNR 3 Tube Support
(9200158)

1x - TNR 4 Post Mount Kit (3200155)

2x - TNR 4 Post
Mount Clamp
(9200157)

31x - Square
Nylok Nut
(54902200)

30x - 1/4 x
12.7mm Pan
Head Bolt
(53453202)

1x - TNR 4
Post Mount
Base
(9200156)

1x - 1/4 x
14.5mm
Pan Head
Bolt
(53452209)

1x - TNR3 Extend Flange Lt
(3310130) (Green)

1x - #2 x 2"
Robertson Driver
(9200014)

9x - TNR 2 Slide Elbow
(3310121) (Green)

2x - Swing Belt Seat
(9320130) Green

1x - Heavy Bracket Set (3205701)

1x - Heavy
C-Bracket
(9200153)

3x - Heavy
L-Bracket
(9200151)

2x -
Heavy Flat
Bracket
(9200149)

1x - Plastic Formed
Washer (18 Pk)
(3290000)

1x - Tic Tac
Toe Assembly
(3320213)

1x - Double Maze
N Wave
Slide
(3318125)

1x - TNR 2 Slide Exit Top
(3310124) (Green)

10x - TNR 4 Clamp Ring
(9300130) (Green)

(9200025)
(9200020)

1x - Acro Bar
(9200131)

1x - DX Swing Hangers
with Quick Links (6 Pk)
(3201950)

1x - Door Hardware (3200710)

2x 9207712
Door Hinge

9207713
Door Catch

1x Magnetic Catch
1x Catch Plate

2x 9207711
Door Handle

1x - TNR3 Short Exit (Green)
(3310132)

1x - Welded Chain Bag (3200173) Green

2x - 20" chain -Green

4x - 48" chain -Green

2x - Acro Handle
(9200133)

1x - Playset Brkt Set (3209080)

3205971
1X - Corner
Bracket (2pk)

3205977
1X - Panel
Corner Brkt
(6pk)

3205942
1X - Flat Panel
Brkt (6pk)

3205960
1X - Flat
Brkt (2pk)

1x - Narrow Angle
Bracket
(9325932)

Part Identification (Reduced Part Size)

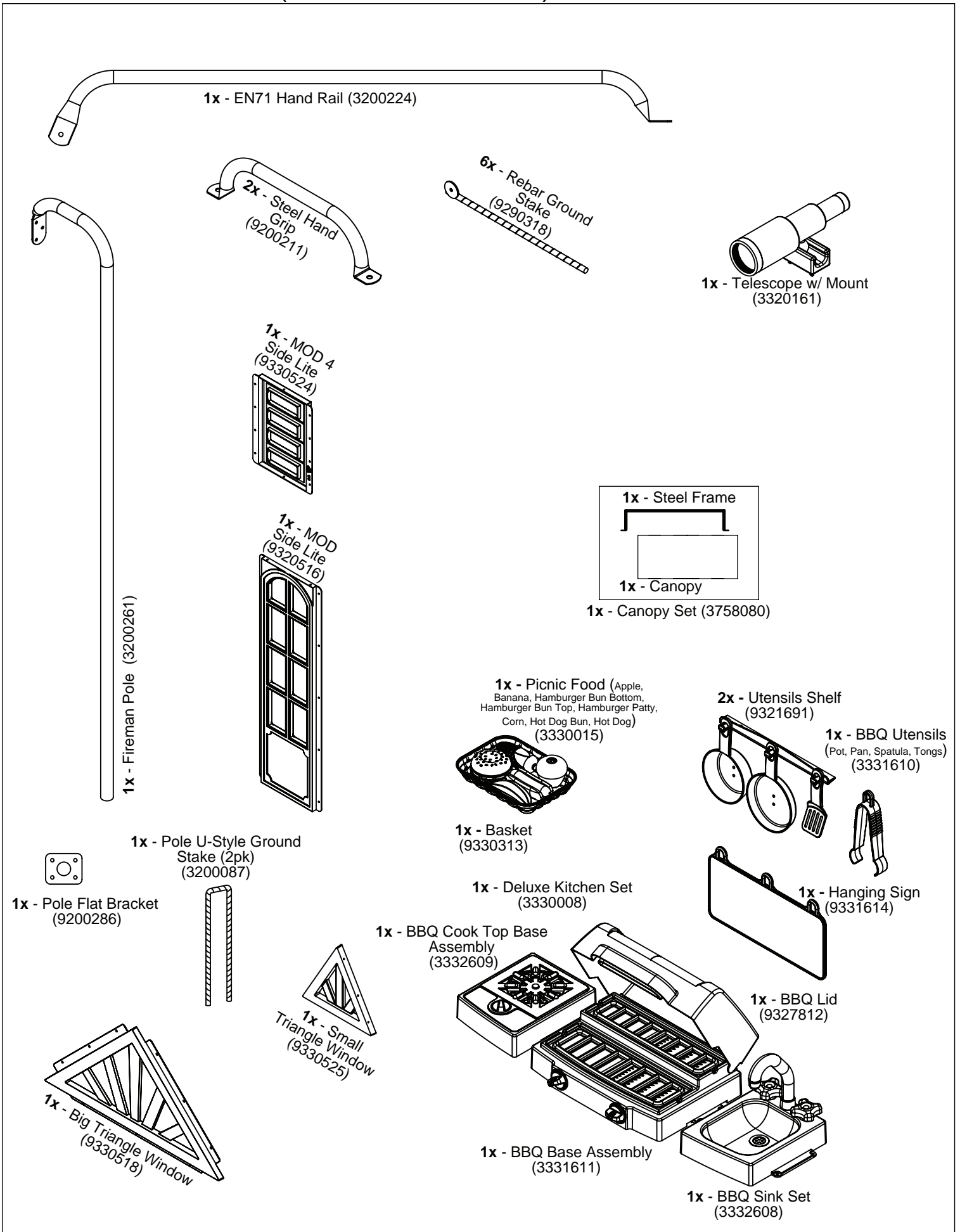

Hardware Identification (Actual Size)

3pc. **H9** - Hex Bolt 1/4 x 1-1/4" - (53703211)
6.4 x 31.8mm

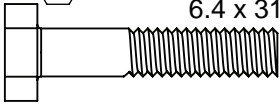

7pc. **WB7** - Wafer Bolt 5/16 x 3" - (53613330)
7.9 x 76.2mm

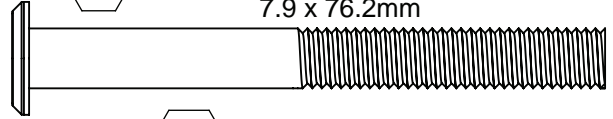

34pc. **H2** - Hex Bolt 1/4 x 2" - (53703220)
6.4 x 50.8mm

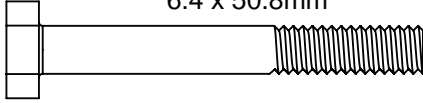

8pc. **WB10** - Wafer Bolt 5/16 x 2-5/8" - (53613329)
7.9 x 66.7mm

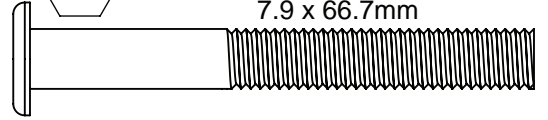

4pc. **H11** - Hex Bolt 1/4 x 2-3/4" - (53703223)

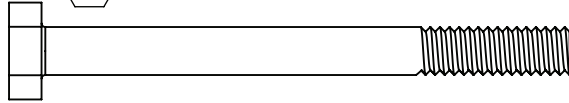

2pc. **WB9** - Wafer Bolt 5/16 x 2-1/8" - (53613324)
7.9 x 54mm



1pc. **H8** - Hex Bolt 1/4 x 4-1/4" - (53703241)

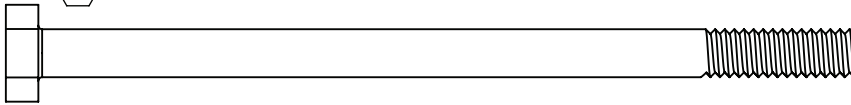

8pc. **WB8** - Wafer Bolt 5/16 x 2-3/8" - (53613326)
7.9 x 60.3mm

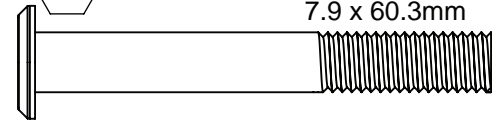

5pc. **LS9** - Lag Screw 5/16 x 4-3/4" - (52213343)

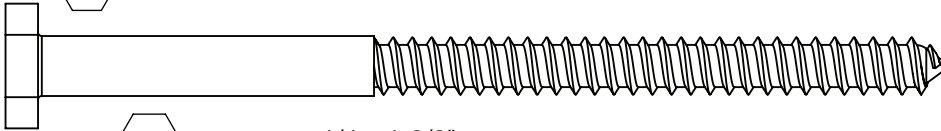

16pc. **WB2** - Wafer Bolt 5/16 x 1-3/8" - (53613316)
7.9 x 25.4mm

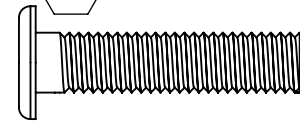

6pc. **WL3** - Wafer Lag 1/4 x 1-3/8" - (52613216)
6.4 x 34.9mm

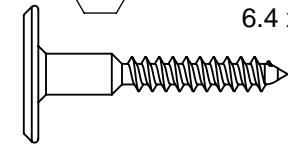

31pc. **WL5** - Wafer Lag 1/4 x 2-1/2" - (52613222)
6.4 x 63.5mm

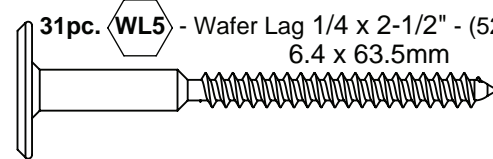

4pc. **G21** - Hex Bolt 5/16 x 3-3/4" - (53703333)
7.9 x 95.3mm

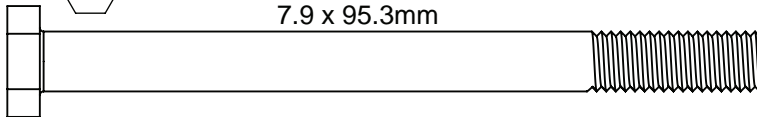

2pc. **G5** - Hex Bolt 5/16 x 4-1/2" - (53703342)
7.9 x 114.3mm

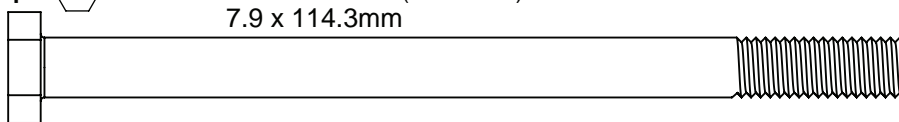

12pc. **G13** - Hex Bolt 5/16 x 6-1/8" - (53703364)
7.9 x 152.4mm

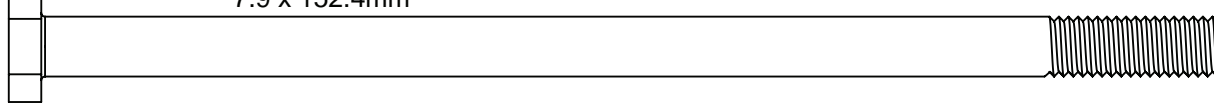

1pc. **G20** - Hex Bolt 3/8 x 4" - (53703840)
9.5 x 101.6mm

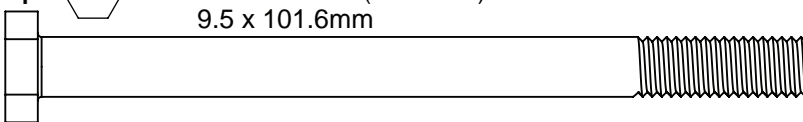



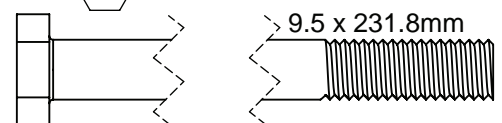



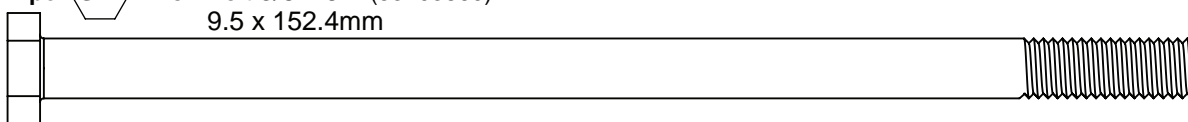



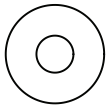
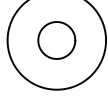
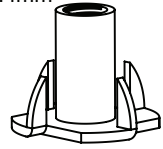

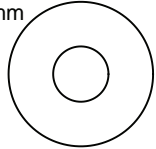

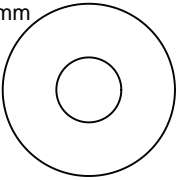
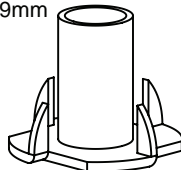
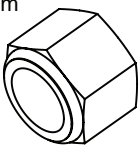
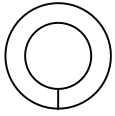
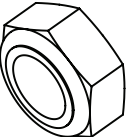
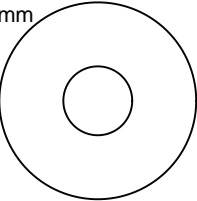
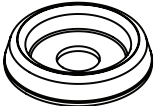
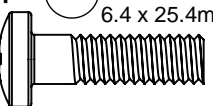
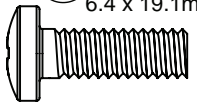
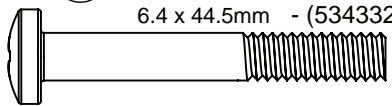
1pc. **G26** - Hex Bolt 3/8 x 9-1/4" - (53703891)
9.5 x 231.8mm

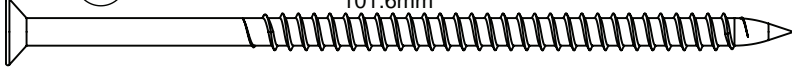

4pc. **G17** - Hex Bolt 3/8 x 6" - (53703860)
9.5 x 152.4mm

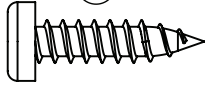
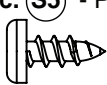

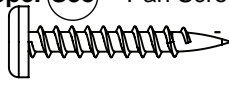
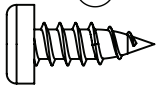
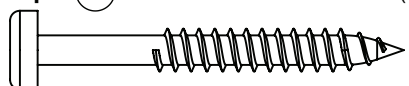
Hardware Identification (Actual Size)

- 5pc. **(FW3)** - #8 Flat Washer - (51003500) 
- 14pc. **(FW0)** - 3/16" Flat Washer - (51103100) 4.8mm 
- 42pc. **(TN1)** - 1/4" T - Nut - (54503200) 6.4mm 
- 56pc. **(LW1)** - 1/4" Lock Washer - (51303200) 6.4mm 
- 52pc. **(FW1)** - 1/4" Flat Washer - (51103200) 6.4mm 
- 73pc. **(LN1)** - 1/4 Lock Nut - (54303200) 6.4mm 
- 89pc. **(FW2)** - 5/16" Flat Washer - (51103300) 7.9mm 
- 42pc. **(TN2)** - 5/16" T - Nut - (54503300) 7.9mm 
- 17pc. **(LN2)** - 5/16" Lock Nut - (54303300) 7.9mm 
- 19pc. **(LW2)** - 5/16" Lock Washer - (51303300) 
- 6pc. **(LN3)** - 3/8 Lock Nut - (54303800) 9.5mm 
- 12pc. **(FW10)** - 3/8" Flat Washer - (51103800) 9.5mm 
- 8pc. **(FW6)** - #12 Screw Bezel - (9299500) 
- 11pc. **(PB6)** - Pan Bolt 1/4 x 1" 6.4 x 25.4mm - (53413210) 
- 49pc. **(PB1)** - Pan Bolt 1/4 x 3/4" 6.4 x 19.1mm - (53453203) 
- 14pc. **(PB3)** - Pan Bolt 1/4 x 1-3/4" 6.4 x 44.5mm - (53433213) 
- 59pc. **(S0)** - Truss Screw #8 x 7/8" - (52933505) 22.2mm 
- 201pc. **(S20)** - Wood Screw #8 x 1-3/8" - (52043516) 34.9mm 
- 46pc. **(S11)** - Wood Screw #8 x 2" - (52043520) 50.8mm 
- 11pc. **(S24)** - Wood Screw #10 x 4" - (52043940) 101.6mm 
- 60pc. **(S3)** - Wood Screw #8 x 2-1/2" - (52043522) 63.5mm 
- 22pc. **(S4)** - Wood Screw #8 x 3" - (52043530) 76.2mm 
- 15pc. **(S6)** - Pan Screw #12 x 1" 25.4mm - (52433610) 
- 7pc. **(S5)** - Pan Screw #8 x 1/2" 12.7mm - (52433502) 
- 33pc. **(S37)** - Pan Screw #7 x 5/8" 15.9mm - (52433009) 
- 8pc. **(S38)** - Pan Screw #7 x 1-1/8" 28.6mm - (52433014) 
- 48pc. **(S8)** - Pan Screw #12 x 3/4" - (52433603) 
- 62pc. **(S7)** - Pan Screw #12 x 2" 50.8mm - (52433620) 
- 6pc. **(S1)** - Wood Screw #8 x 1-1/8" - (52043514) 

Step 1: Inventory Parts - Read This Before Starting Assembly

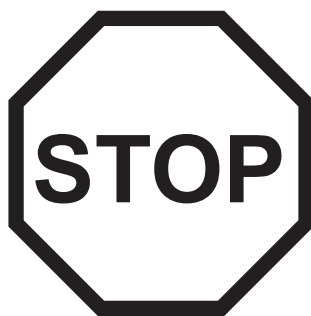
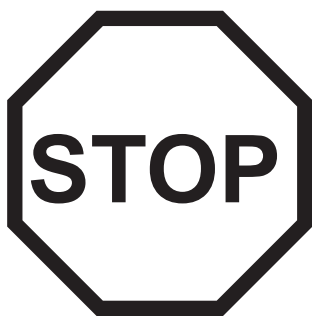
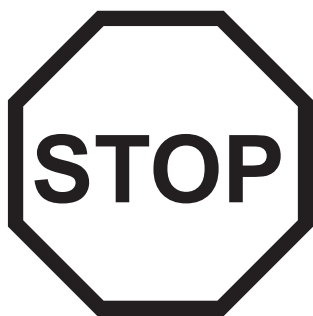

A. This is the time for you to inventory all your hardware, wood and accessories, referencing the parts identification sheets. This will assist you with your assembly.

- The wood pieces will have the key number stamped on the ends of the boards. Organize the wood pieces by step, as per the key numbering system below.

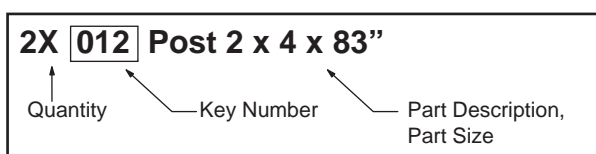

- Please refer to Page 6 for proper hardware assembly.
- Each step indicates which bolts and/or screws you will need for assembly, as well as any flat washers, lock washers, t-nuts or lock nuts.

B. If there are any missing or damaged pieces or you need assistance with assembly please contact the consumer relations department directly. Call us before going back to the store.

customerservice@kidkraft.com
 Online Parts Replacement: parts.kidkraft.com
 To warranty your product: kidkraft.com/warranty/
 Customer Service:
 1(800) 933-0771 or (972) 385-0100

Europe Customer Service: +31 (0)20 305 8620
 europecustomerservice@kidkraft.com
 EU Online Parts Replacement: parts.kidkraft.eu

C. Read the assembly manual completely, paying special attention to ANSI warnings; notes; and safety/maintenance information on pages 1 - 6.

D. Before you discard your cartons fill out the form below.

- The carton I.D. stamp is located on the end of each carton. The tracking number is located on the KidKraft ID Plaque (9320374).
- Please retain this information for future reference. You will need this information if you contact the Consumer Relations Department.

MODEL NUMBER: F29080

CARTON I.D. STAMP: ___ ___ ___ ___ 14459 ___ (Box 1)

CARTON I.D. STAMP: ___ ___ ___ ___ 14459 ___ (Box 4)

CARTON I.D. STAMP: ___ ___ ___ ___ 14459 ___ (Box 2)

CARTON I.D. STAMP: ___ ___ ___ ___ 14459 ___ (Box 5)

CARTON I.D. STAMP: ___ ___ ___ ___ 14459 ___ (Box 3)

CARTON I.D. STAMP: ___ ___ ___ ___ 14459 ___ (Box 6)

TRACKING NUMBER (from ID Plaque): _____

Step 2: Access Ladder/Rope Wall Assembly

Part 1



A: Place (9054) Left Access on one side of 4 (9545) Treads and (9055) Right Access on the other side with the grooves facing in. (fig. 2.1)

B: Fit each (9545) Tread into grooves on both (9054) and (9055) Access rails, make sure the top edge of the (9545) Treads are flush to the front of the Access rails. (fig. 2.1 and 2.2)

C: Pre-drill pilot holes with a 1/8" drill bit and attach rails and treads together using 4 (S3) #8 x 2-1/2" Wood Screws per tread. (fig. 2.1, 2.3)

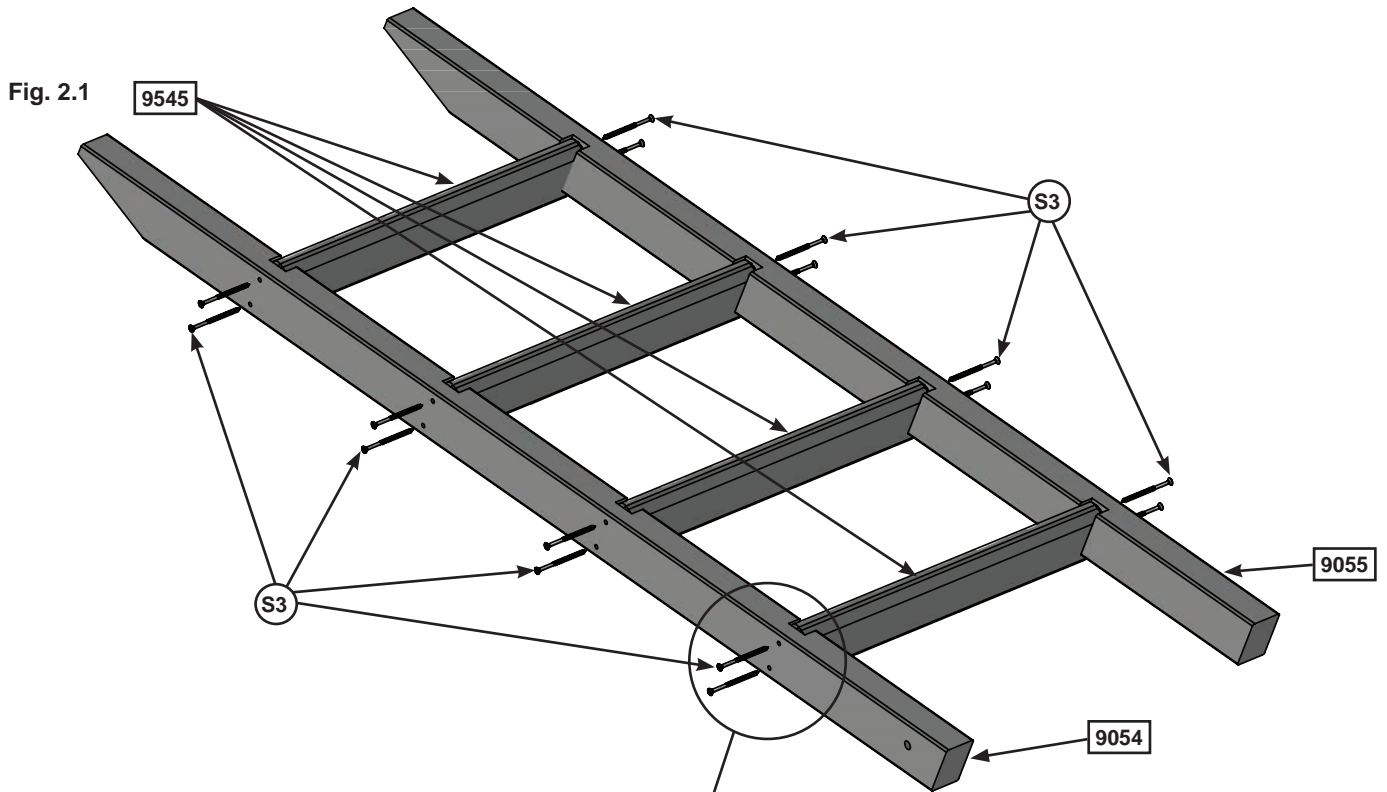
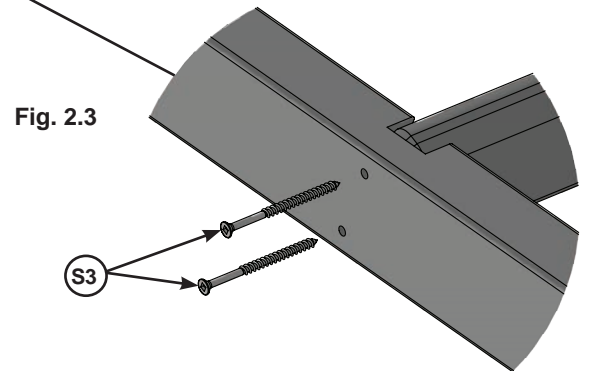
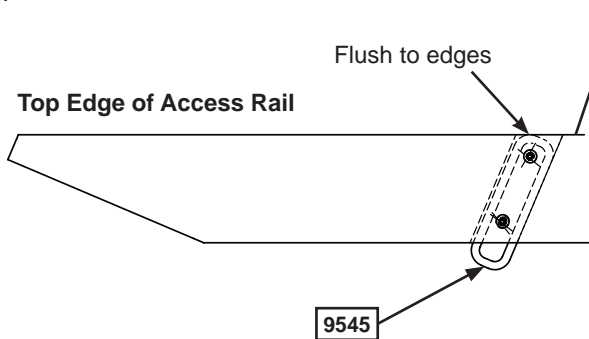

Fig. 2.2
End View



Wood Parts

- 1 x **9054** Left Access 1 3/8 x 2 1/2 x 57 53/64"
- 1 x **9055** Right Access 1 3/8 x 2 1/2 x 57 53/64"
- 4 x **9545** Tread 15/16 x 3 1/4 x 16 3/16"

Hardware

- 16 x **S3** #8 x 2-1/2" Wood Screw

Step 2: Access Ladder/Rope Wall Assembly

Part 2



D: Place (9544) Short Support on each access rail so there is a 2-3/8" gap between (9544) Short Support and the top (9545) Tread. Attach using 4 (S20) #8 x 1-3/8" Wood Screws. (fig. 2.4, 2.5)

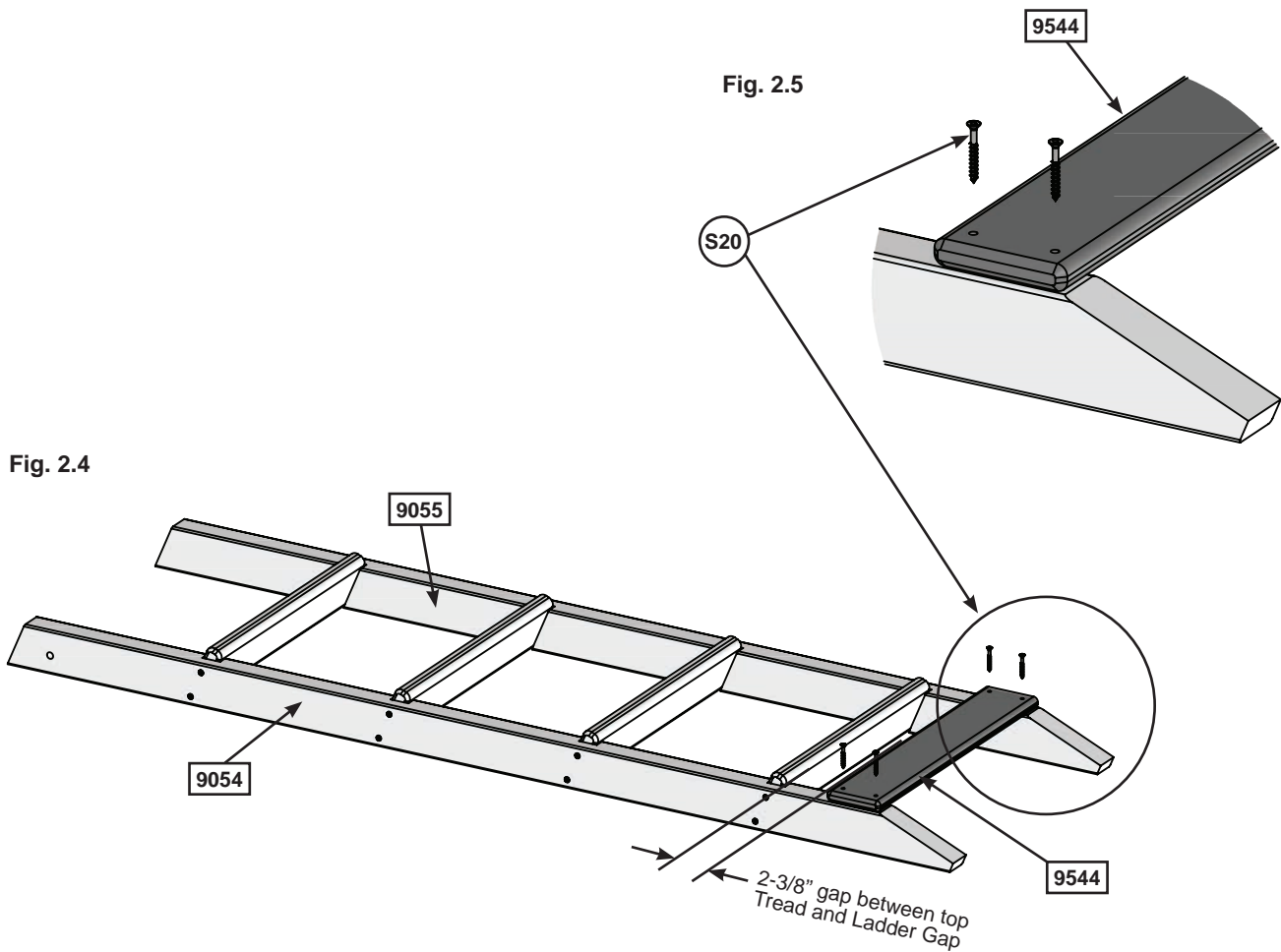

Wood Parts

1 x **9544** short Support 5/8 x 3 1/4 x 17 11/16"

Hardware

4 x **S20** #8 x 1-3/8" Wood Screw

Step 2: Access Ladder/Rope Wall Assembly Part 3

E: Place (9058) Rope Rail on the ground next to (9055) Right Access so it matches the orientation of the two access rails as shown in fig. 2.6. Attach (9543) Support Top flush to the top of Access Ladder assembly and (9058) Rope Rail using 3 (S20) #8 x 1-3/8" Wood Screws in the top holes and 3 (S11) #8 x 2" Wood Screws in the bottom holes. Pilot holes in (9543) Support Top should be centered over the rails. (fig. 2.6 & 2.7)

Fig. 2.6

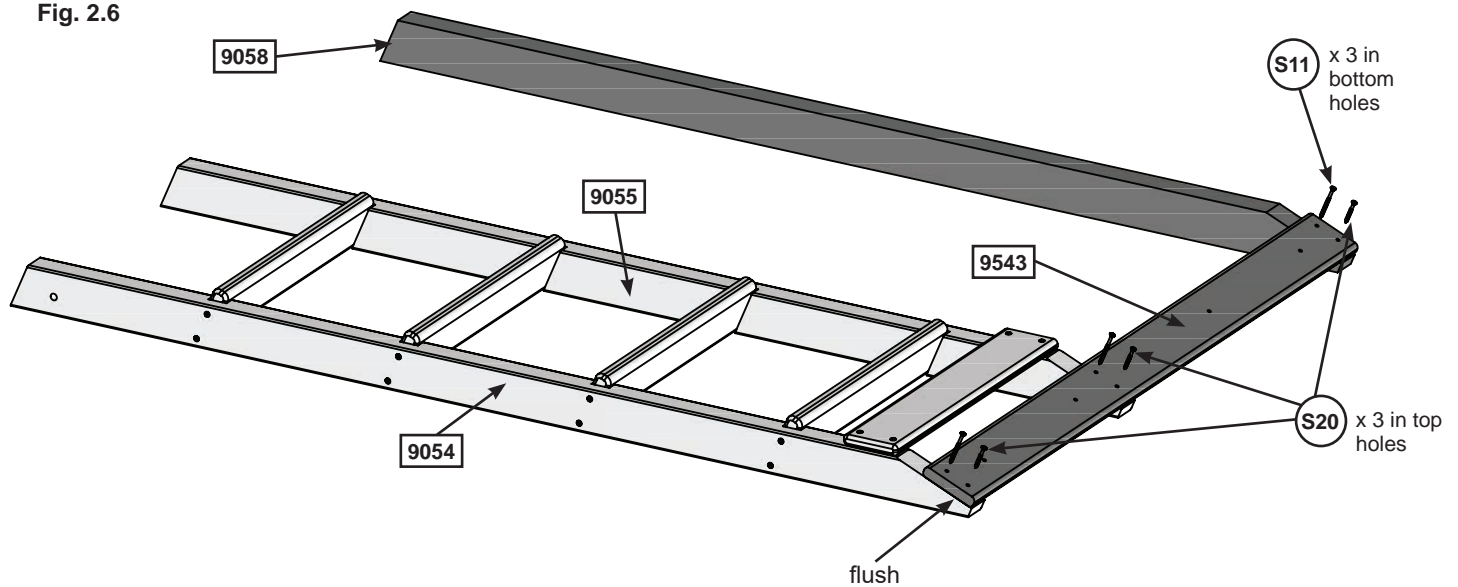
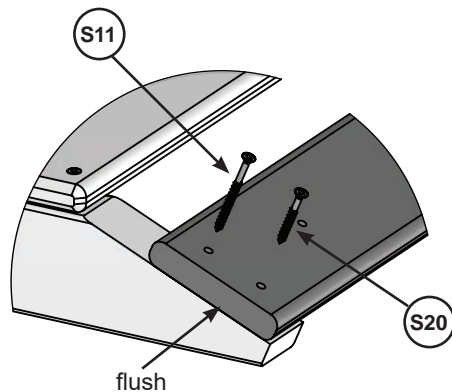

Fig. 2.7



Wood Parts

- 1 x 9058 Rope Rail 1 3/8 x 2 1/2 x 57 53/64"
- 1 x 9543 Support Top 5/8 x 3 1/4 x 40 11/16"

Hardware

- 3 x S11 #8 x 2" Wood Screw
- 3 x S20 #8 x 1-3/8" Wood Screw

Step 3: Rockwall Assembly



A: Place (9546) Access Board Top flush to the top of the Access Ladder/Rockwall Assembly and 1 (9547) Access Board at the bottom of the assembly as shown in fig. 3.1. Measure 2- 3/8" down from the (9546) Access Board Top and place 1 (9547) Access Board. Do not screw boards down yet.

Note: Rock Boards are to be flush to (9055) Right Access and pilot holes are centered over (9058) Rope Rail. (fig. 3.1)

B: Space the remaining 5 (9547) Access Boards by 2-3/8" making sure that all boards are level and the assembly is square, Pre drill holes using a 1/8" Drill Bit then attach all boards except for (9546) Access Board Top using 4 (S7) #12 x 2" Pan Screws per board. (9546) Access Board Top to be attached in Step 11, Part 2, keep aside until needed.

Fig. 3.1

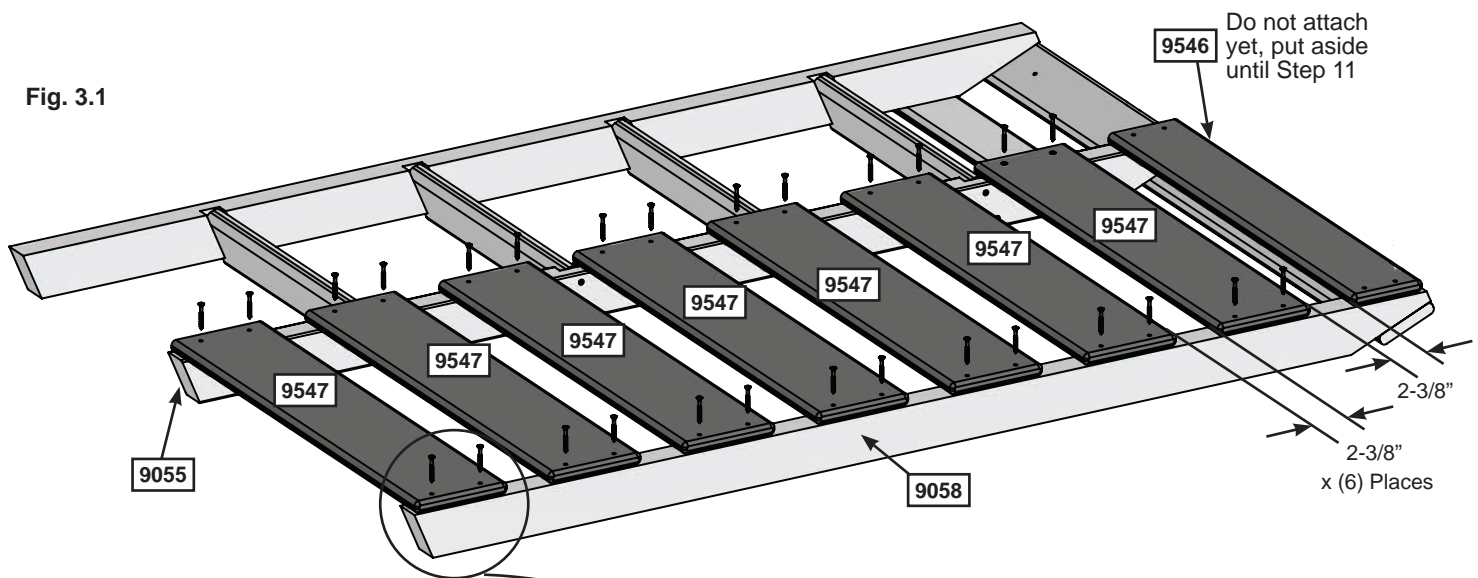
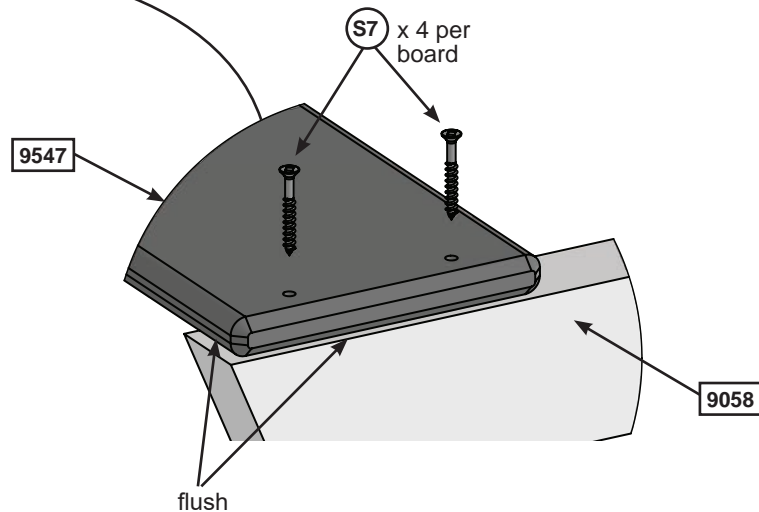

Fig. 3.2



Wood Parts

- 7 x 9547 Access Board 5/8 x 5 1/4 x 24 5/16"
- 1 x 9546 Access Board Top 5/8 x 4 x 24 5/16"

Hardware

- 28 x S7 #12 x 2" Pan Screw

Step 4: Frame Assembly

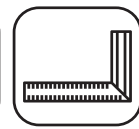

A: With a helper, stand (9286) Front Panel Assembly and (9287) Back Panel Assembly and unfold each piece at the hinges. (fig. 4.1)

B: Place both sections together as shown in fig. 4.1 making sure that they are square. Pre-drill using a 3/16" drill bit and attach panels together at each end using 8 (WL5) 1/4 x 2- 1/2" Wafer Lags per end. (fig. 4.1)

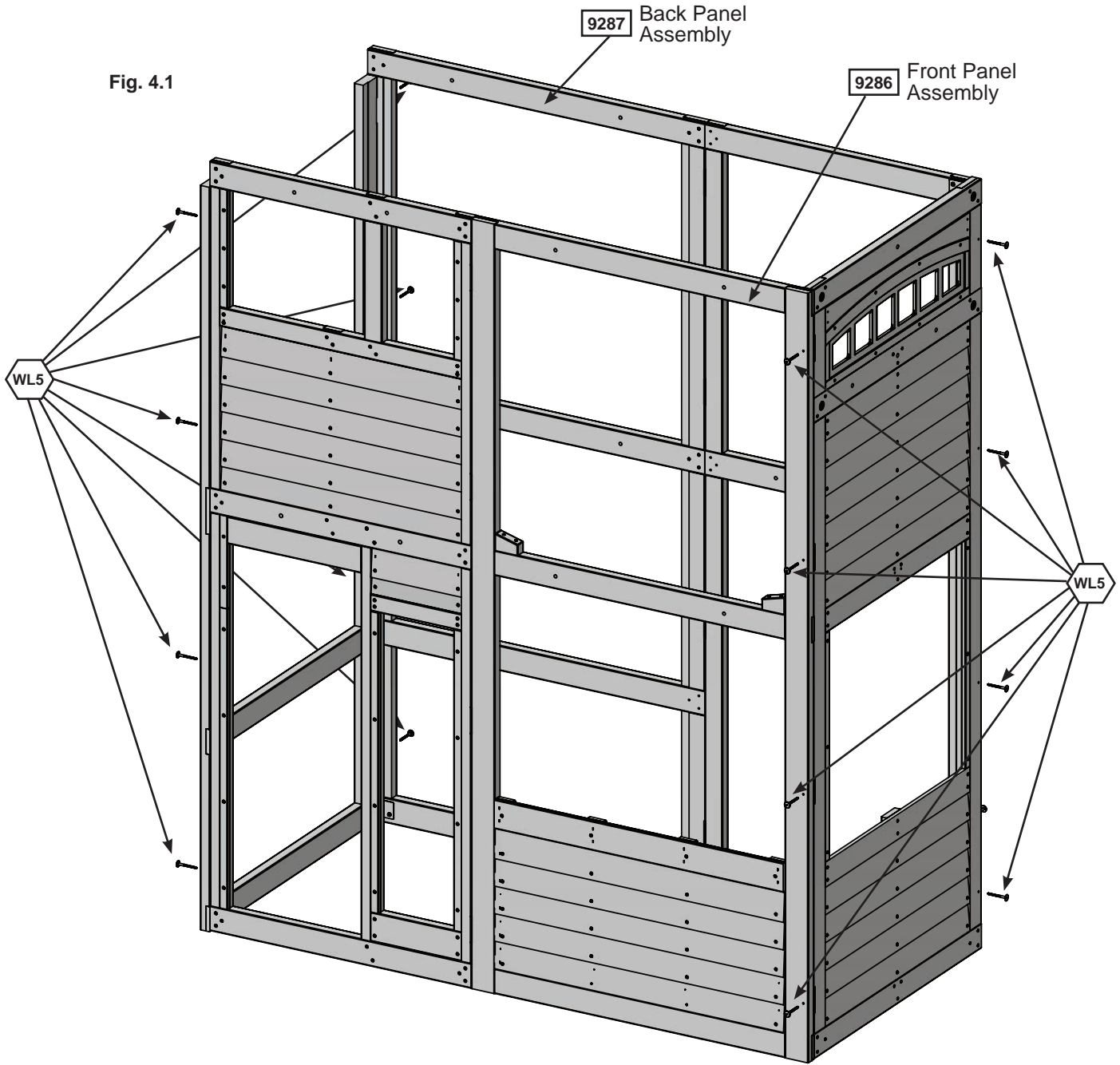

Wood Parts

- 1 x Back Panel Assembly 3-1/2 x 43 x 92"
- 1 x Front Panel Assembly 3-1/2 x 43 x 92"

Hardware

- 16 x 1/4 x 2-1/2" Wafer Lag

Step 5: Join the Frame Assemblies

Part 1

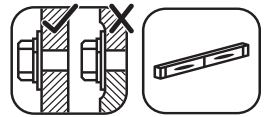

A: Place 1 (9537) Floor Joist along the bottom of the front and back side walls so they are centered over the seams where the panels join together and are flush to the bottom of each panel. Check to make sure the (9537) Floor Joists are level then attach each joist using 4 (S7) #12 x 2" Pan Screws per board. (fig. 5.1 & 5.2)

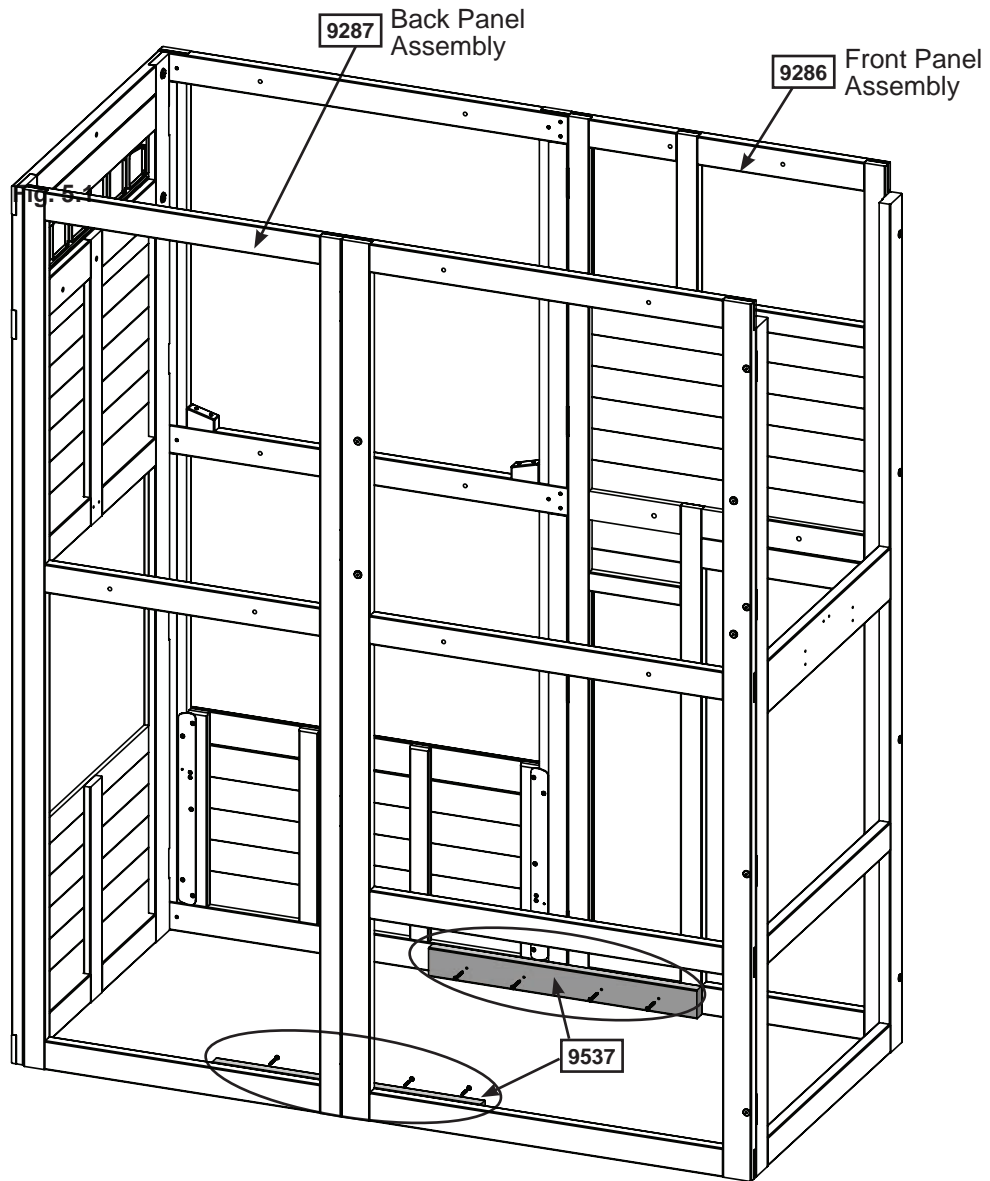
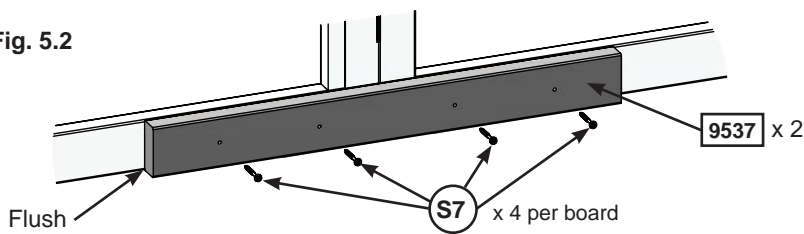

Fig. 5.2



Wood Parts

2 x 9537 Floor Joist 1-1/4 x 3 x 28-1/8"

Hardware

8 x S7 #12 x 2" Pan Screw

Step 5: Join the Frame Assemblies

Part 2



A: From inside the assembly, halfway up the front side wall, place 1 (9538) Side Joist so that it's 5/8" below the panels and tight against the end walls. Loosely attach 1 (9538) Side Joist to (9286) Front Panel Assembly and (9287) Back Panel Assembly with 4 (WB10) 5/16 x 2-5/8" Wafer Bolts (with flat washer and t-nut). Bolts are installed from inside the assembly. Make sure (9538) Side Joist is level then tighten bolts. (fig. 5.3, 5.4 and 5.5)

B: Repeat Step A to attach 1 (9538) Side Joist to back side wall. (fig. 5.3, 5.4 and 5.5)

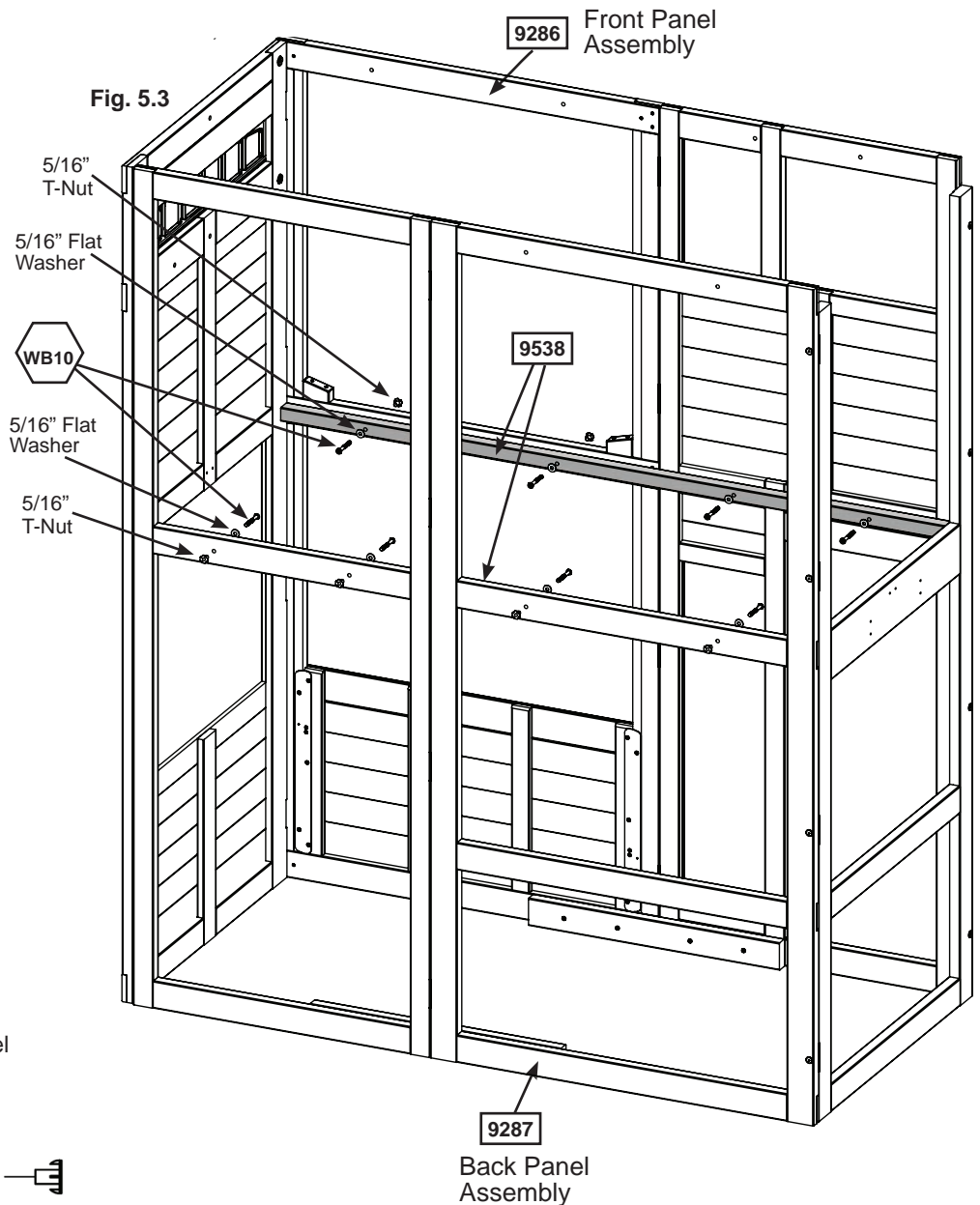

Fig. 5.4
Inside View

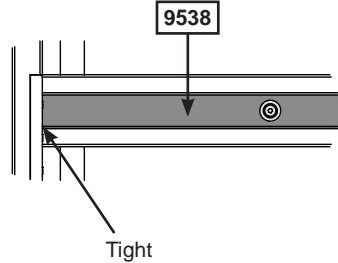
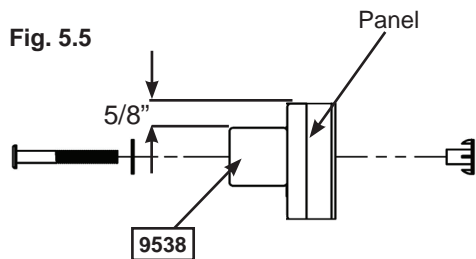

Fig. 5.5



Wood Parts

2 x 9538 Side Joist 1-1/4 x 1-1/4 x 74-7/8"

Hardware

8 x WB10 5/16 x 2-5/8" Wafer Bolt
(5/16" flat washer, 5/16" t-nut)

Step 6: Attach Floor Joist Part 1

A: Place 1 (9540) Floor Board tight to End Slide Panel and 1 (9051) Floor Board tight to SW Wall Panel then attach each to the (9538) Side Joists with 4 (S20) #8 x 1-3/8" Wood Screws per board. (fig. 6.1, 6.2 and 6.3)

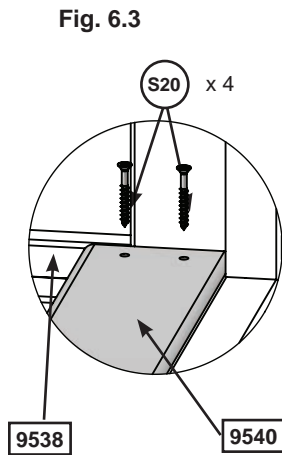
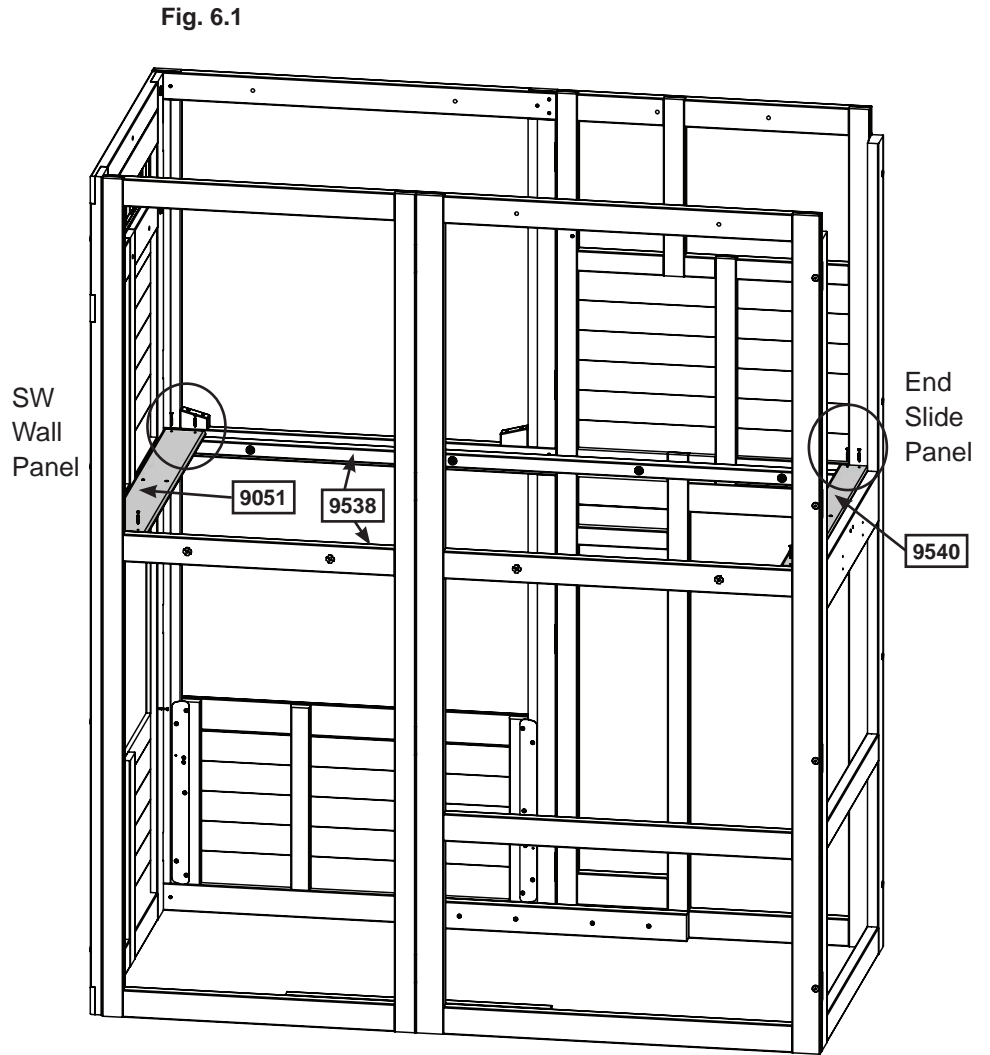
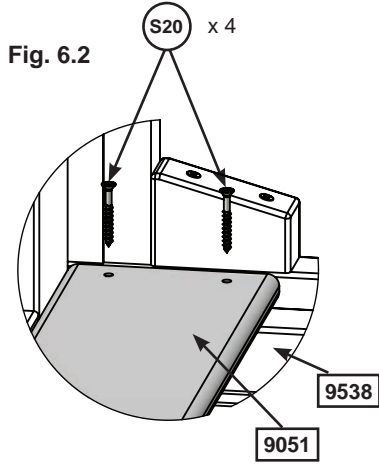

Wood Parts

- 1 x 9540 Floor Board 5/8 x 3-1/4 x 35-5/8"
- 1 x 9051 Floor Board 5/8 x 4-1/2 x 35-5/8"

Hardware

- 8 x S20 #8 x 1-3/8" Wood Screw

Step 6: Attach Floor Joist Part 2



B: Place (9542) Long Floor Joist tight to the bottom of each Floor Board, centered over the pilot holes on the End Slide Panel and SW Wall Panel then attach with 2 (S4) #8 x 3" Wood Screws per panel. Attach (9540) and (9051) Floor Boards to (9542) Long Floor Joist with 2 (S20) #8 x 1-3/8" Wood Screws per board. (fig. 6.4, 6.5)

Fig. 6.4

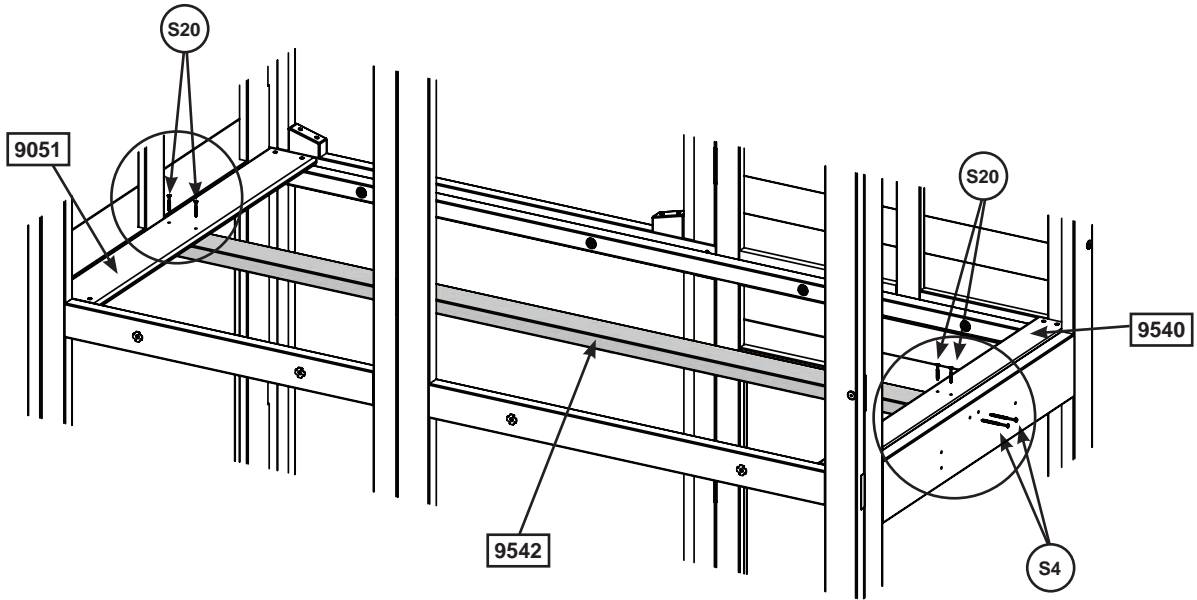
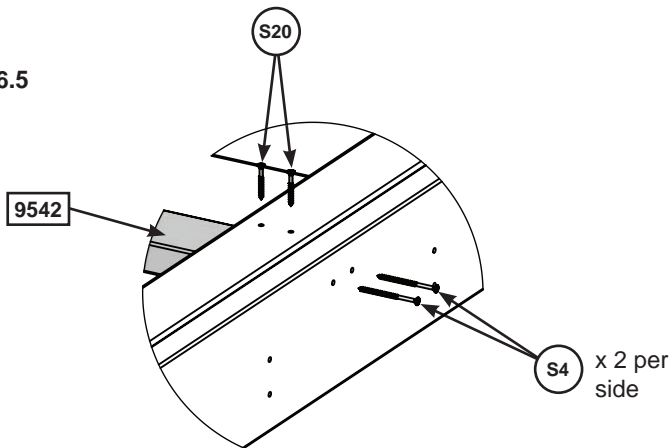

Fig. 6.5



Wood Parts

1 x [9542] Long Floor Joist 1-1/4 x 3 x 75-1/16"

Hardware

4 x (S20) #8 x 1-3/8" Wood Screw

4 x (S4) #8 x 3" Wood Screw

Step 7: Install Brackets Part 1

A: On the inside of the assembly attach the Back Wall Panels using 2 Flat Panel Brackets in the places shown with 4 (S8) #12 x 3/4" Pan Screws per bracket. (fig. 7.1, 7.2 and 7.3)

B: Repeat Step A to attach Front Panels. (fig. 7.1, 7.2 and 7.3)

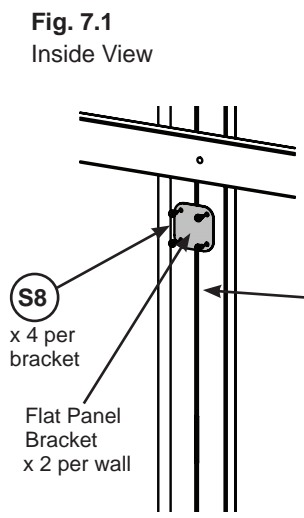
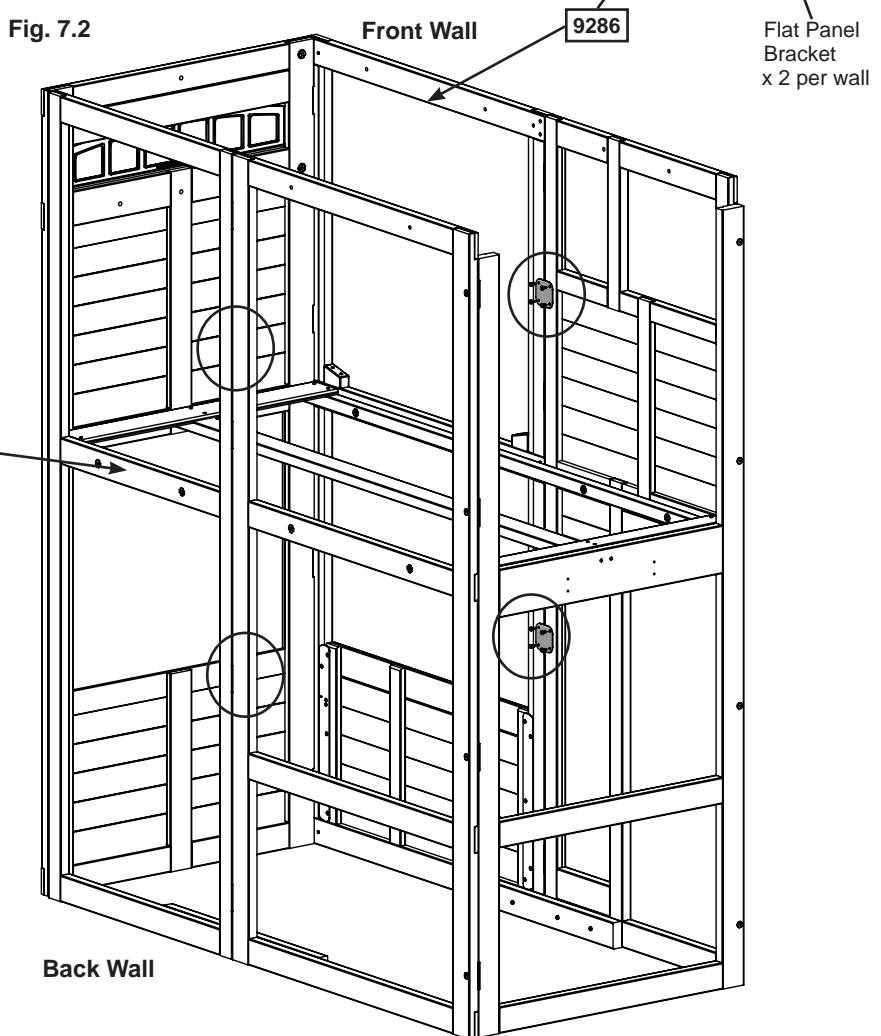
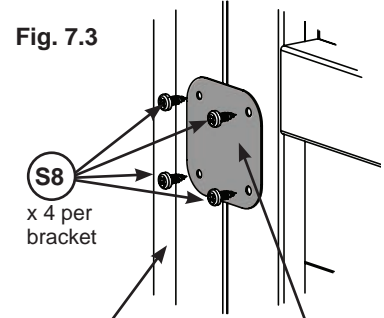

Hardware

16 x  #12 x 3/4" Pan Screw

Other Parts

4 x Flat Panel Bracket

Step 7: Install Brackets

Part 2

C: At all four corners on the bottom and the two top swing wall corners, attach 1 Panel Corner Bracket with 4 (S8) #12 x 3/4" Pan Screws per bracket. (fig. 7.4 & 7.5)

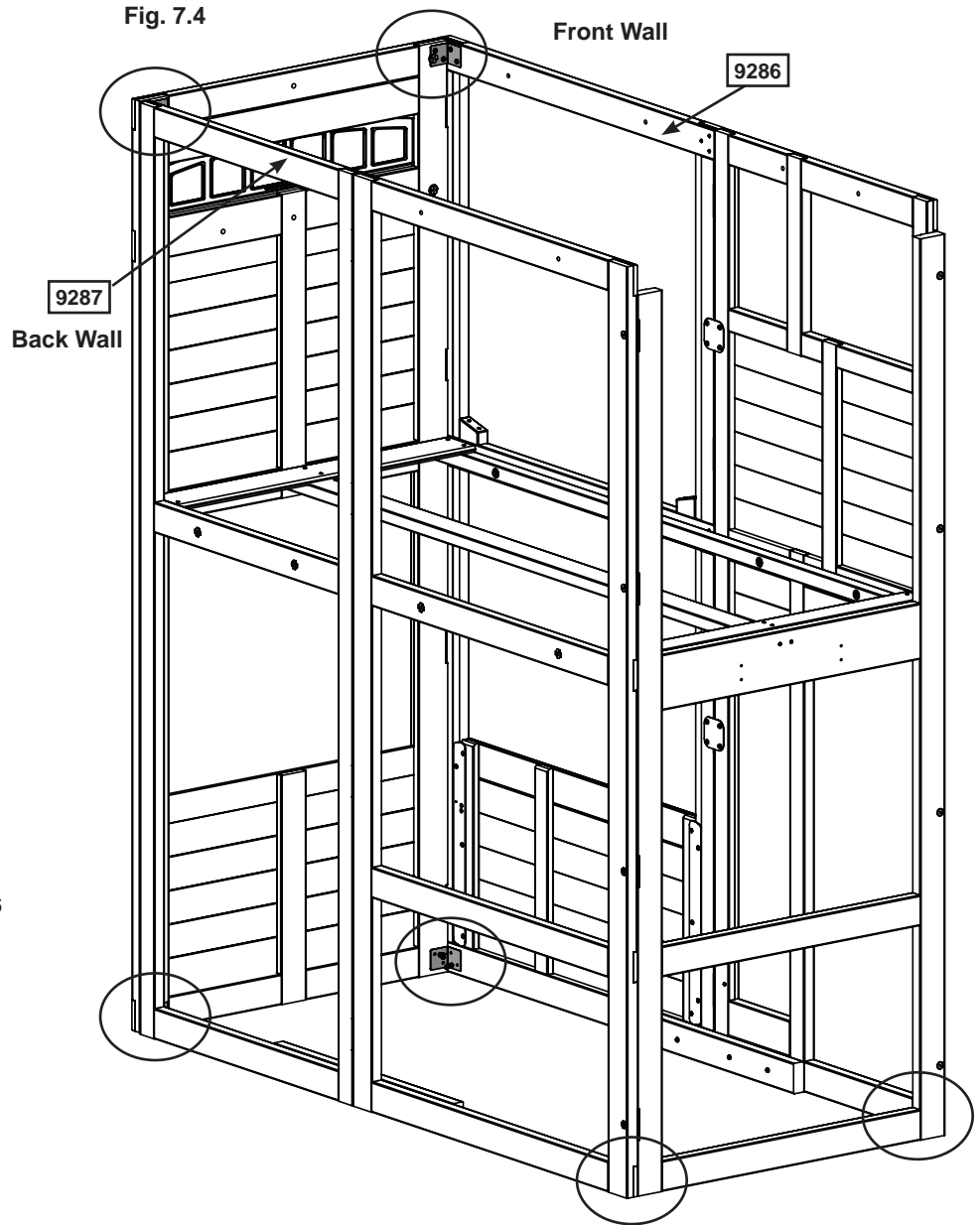
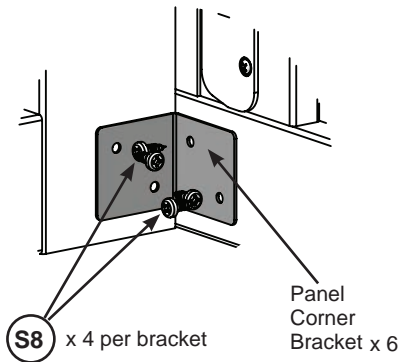



Fig. 7.5
Inside View



Hardware
24 x  #12 x 3/4" Pan Screw

Other Parts
6 x Panel Corner Bracket

Step 8: Floor Assembly

A: Place 1 (9540) Floor Board next to the (9540) Floor Board previously installed. Place the remaining (9051) Floor Boards in the opening making sure that all 15 boards are evenly spaced. Attach using 6 (S20) #8 x 1- 3/8" Wood Screws per board. (fig. 8.1 and 8.2)

Fig. 8.1

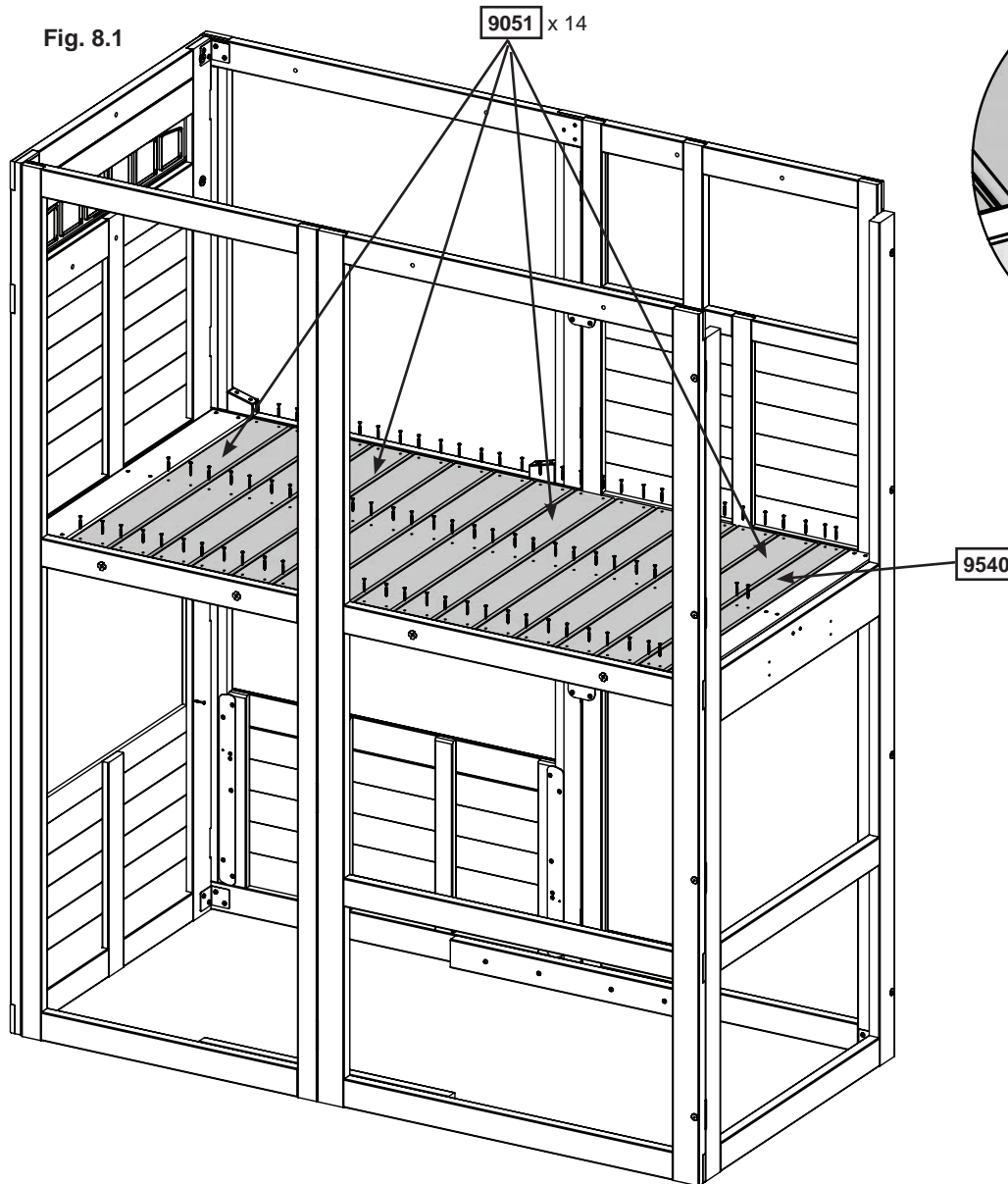
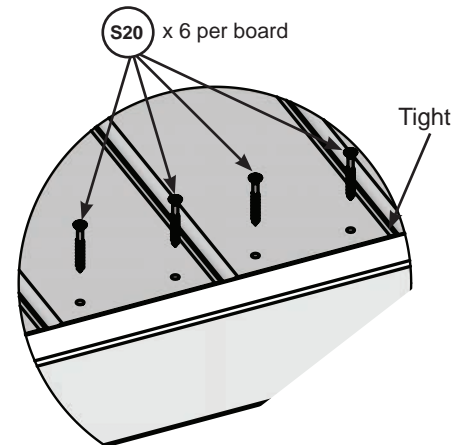

Fig. 8.2



Wood Parts

14 x 9051 Floor Board 5/8 x 4 1/2 x 35 5/8
1 x 9540 Floor Board 5/8 x 3 1/4 x 35 5/8

Hardware

90 x S20 #8 x 1-3/8" Wood Screw

Step 9: Attach Wall Top

A: From inside the assembly, place (9541) End Wall Top in the opening of SW Wall Panel so that it's tight to the corners of the panels and the overhang is facing in. Attach using 1 (S11) #8 x 2" Wood Screw at each end as shown in fig. 9.1 and 9.2.

B: At the top of the slat, flush to the (9541) End Wall Top, attach 1 Corner Bracket using 3 (S37) #7 x 5/8" Pan Screws. (fig. 9.2)

Fig. 9.1

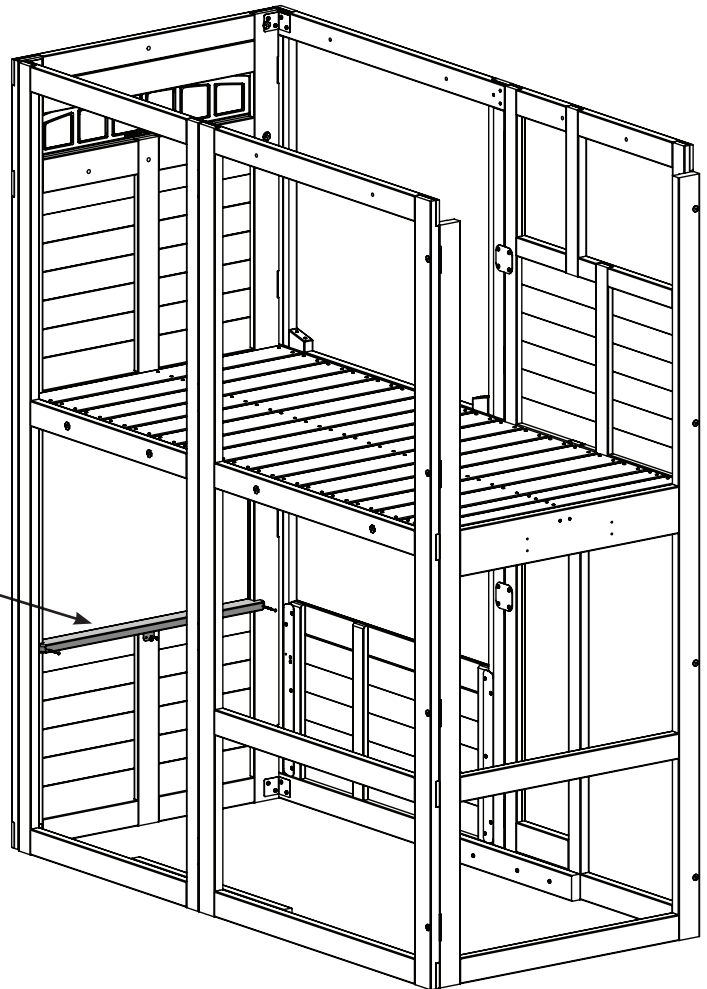
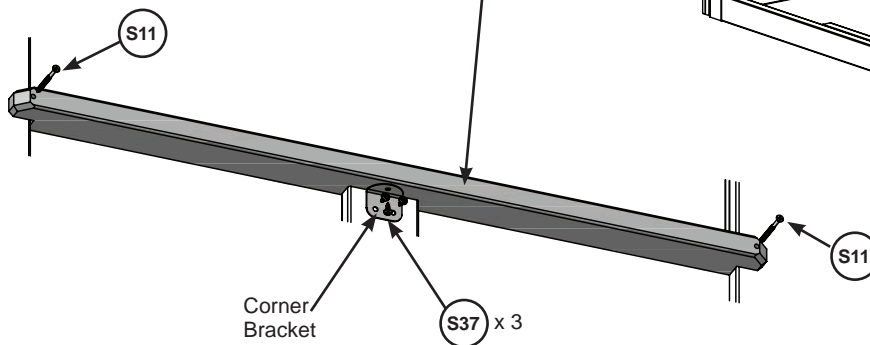

Fig. 9.2
Inside View



Wood Parts

1 x 9541 End Wall Top 15/16 x 2 1/4 x 32"

Hardware

2 x S11 #8 x 2" Wood Screw
3 x S37 #7 x 5/8" Pan Screw

Other Parts

1 x Corner Bracket

Step 10: Attach Diagonal

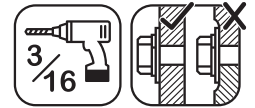

A: Loosely attach (2606) SW Ground to (2607) Diagonal with 1 (WB9) 5/16 x 2-1/8" Wafer Bolt (with flat washer and t-nut) then place (2607) Diagonal tight and flush to the front of (9286) Front Panel Assembly. (2606) SW Ground to be flush to the bottom of (9286) Front Panel Assembly. (fig. 10.1 and 10.2)

B: Pre-drill pilot hole with a 3/16" drill bit then attach (2607) Diagonal to (9286) Front Panel Assembly with 1 (WL5) 1/4 x 2-1/2" Wafer Lag (with flat washer), checking that it remains flush to outside edge. (fig. 10.1 and 10.2)

C: Making sure bottom of (2606) SW Ground is flush to bottom of (9286) Front Panel Assembly then attach with 2 (S11) #8 x 2" Wood Screws and 1 (S4) #8 x 3" Wood Screw then tighten the bolt.

D: Repeat to install Diagonal on the opposite side. (fig 10.1)

Fig. 10.1

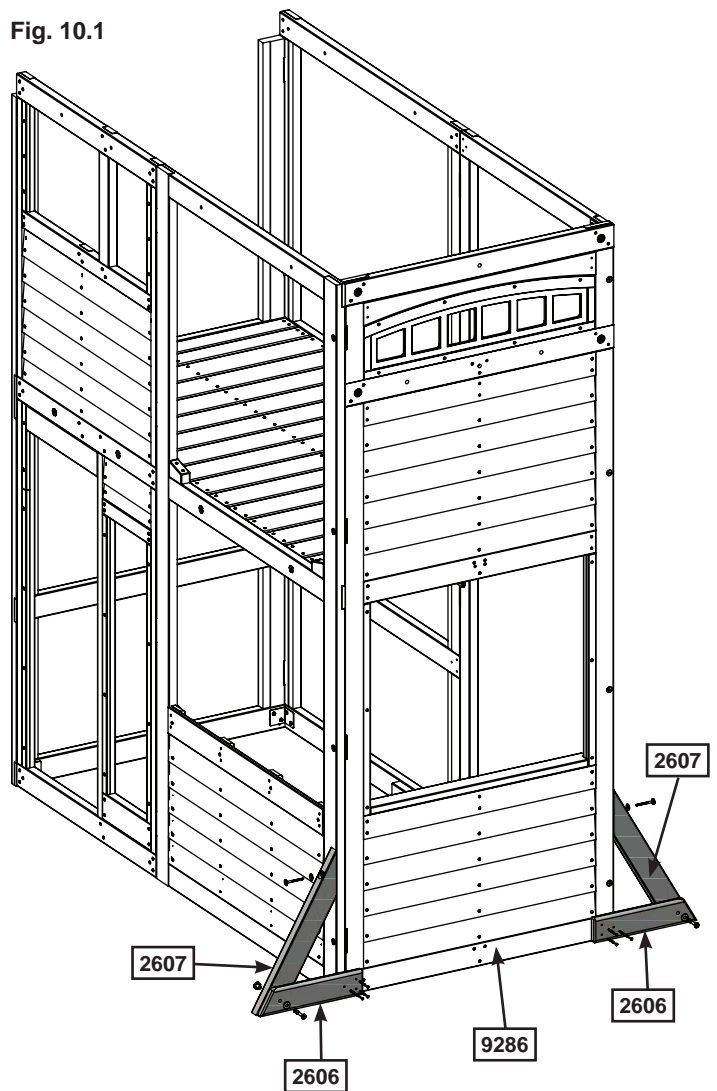
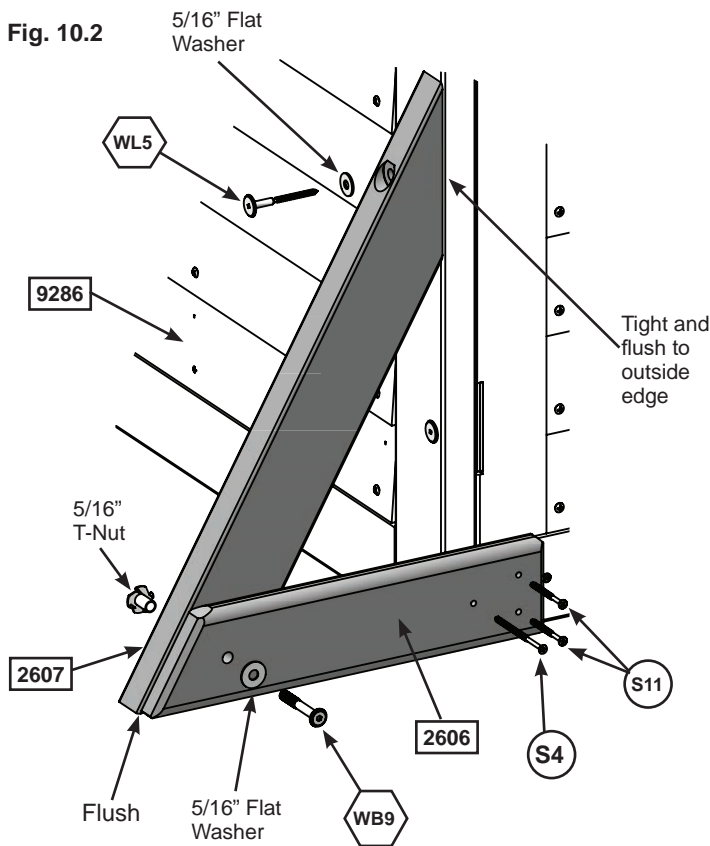

Fig. 10.2



Wood Parts

- 2 x SW Ground 15/16 x 3 1/4 x 14 3/16"
- 2 x Diagonal 1 1/4 x 3 x 22"

Hardware

- 2 x 5/16 x 2-1/8" Wafer Bolt (5/16" flat washer, 5/16" t-nut)
- 2 x 1/4 x 2-1/2" Wafer Lag (5/16" flat washer)
- 2 x #8 x 3" Wood Screw
- 4 x #8 x 2" Wood Screw

Step 11: Attach Access Ladder/Rockwall Assembly Part 1

A: Place Access Ladder/Rockwall Assembly from Step 2 against (9287) Back Panel Assembly, flush to the outside edge and flush to the top of the floor boards then attach with 4 (S20) #8 x 1-3/8" Wood Screws. (fig. 11.1)

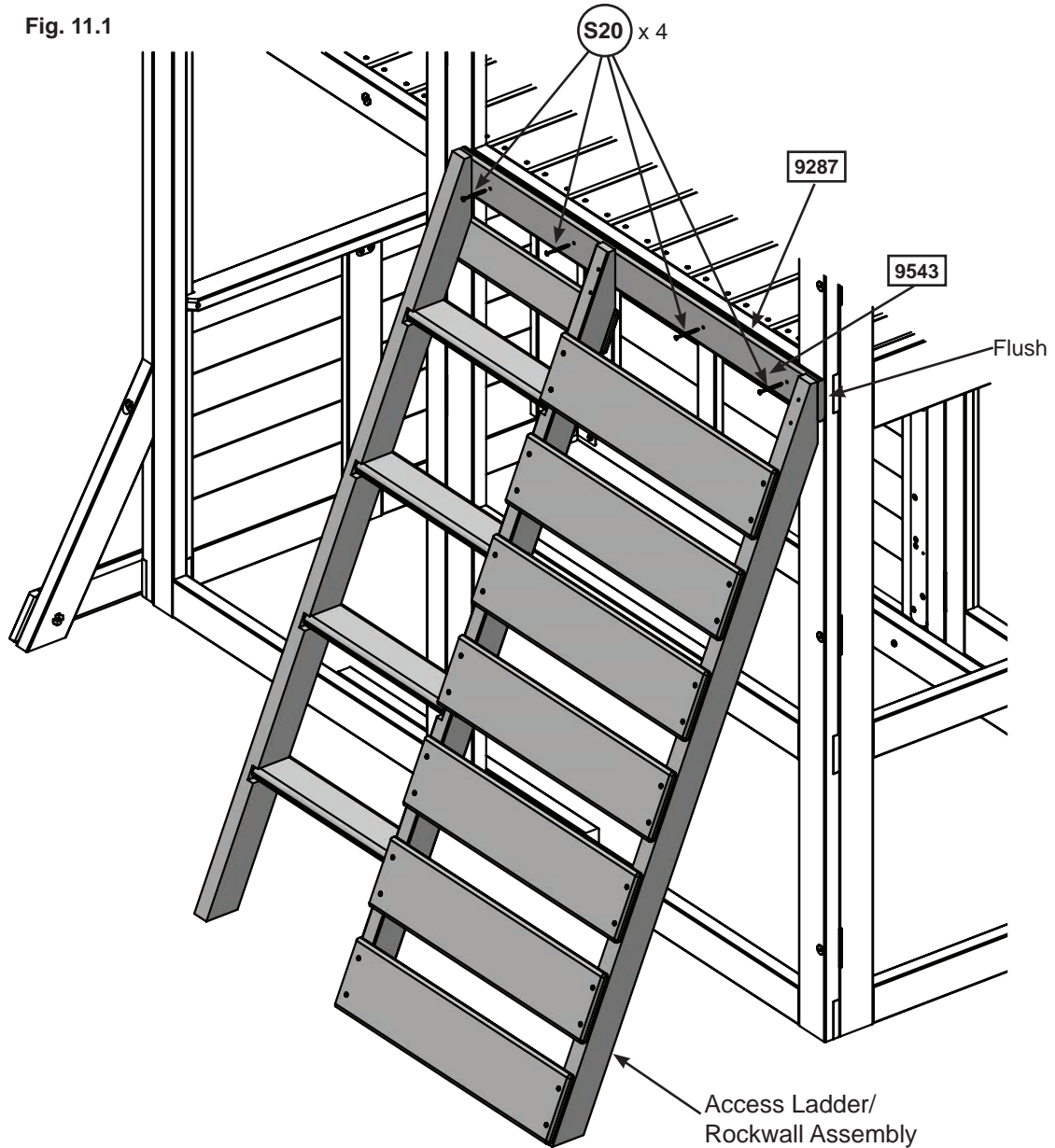

Hardware

4 x S20 #8 x 1-3/8" Wood Screw

Step 11: Attach Access Ladder/Rockwall Assembly Part 2



B: Place (9546) Access Board Top from Step 3, Part 1 against (9055) Right Access and (9058) Rope Rail and flush to the top, Pre drill holes using a 1/8" Drill Bit then attach with 4 (S7) #12 x 2" Pan Screws. (fig. 11.2)

Fig. 11.2

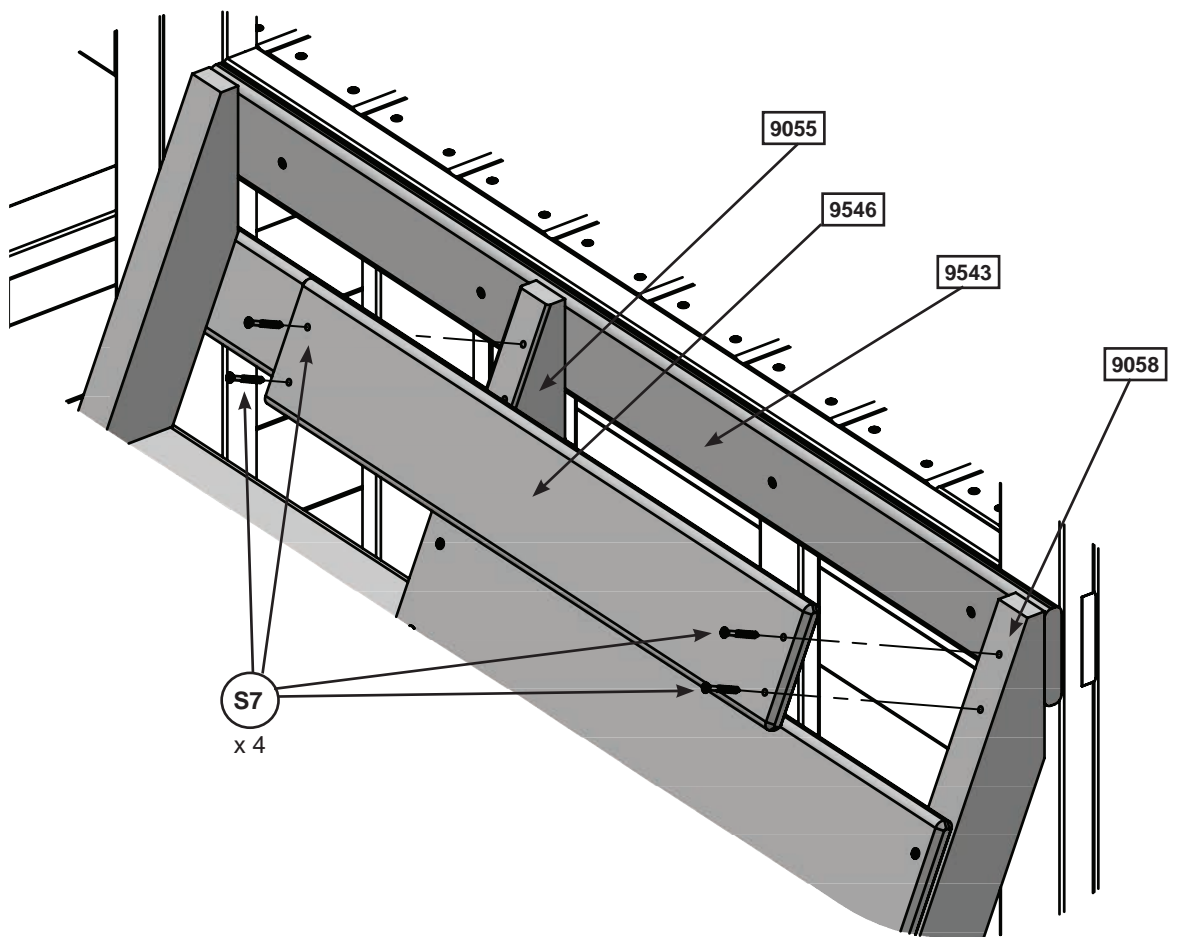

Hardware

4 x  #12 x 2" Pan Screw

Step 11: Attach Access Ladder/Rockwall Assembly Part 3

C: Place (9548) Ground Brace so that the angled end is flush to the front and bottom of (9058) Rope Rail and other end is flat against the (9287) Back Wall Assembly. Attach using 4 (S11) #8 x 2" Wood Screws and 1 (S4) #8 x 3" Wood Screw. (fig. 11.3 and 11.4)

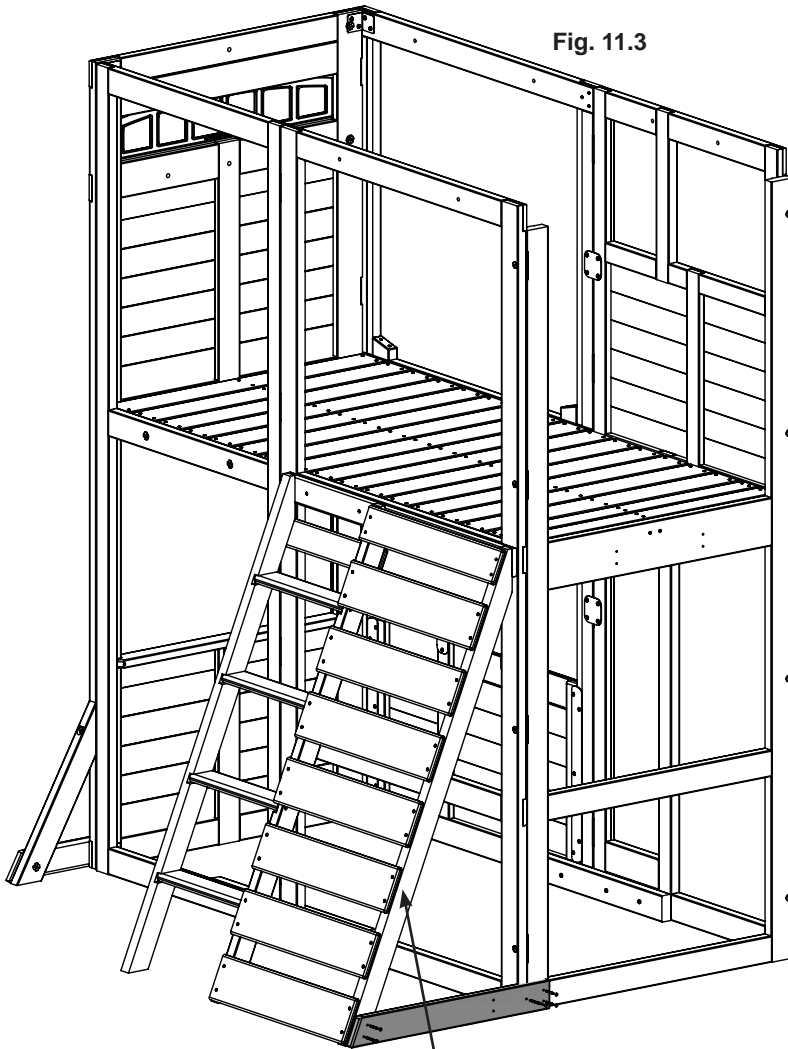

Fig. 11.3

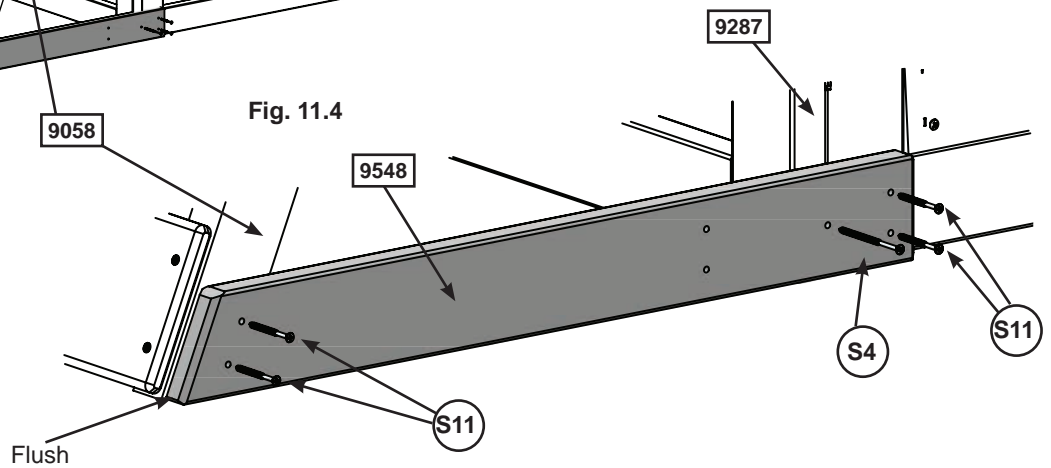

Fig. 11.4

Wood Parts

1 x 9548 Ground Brace 15/16 x 3 1/4 x 27 3/4"

Hardware

4 x S11 #8 x 2" Wood Screw

1 x S4 #8 x 3" Wood Screw

Step 12: Attach Steel Hand Grips and Handrail to Fort Part 1



A: On the inside edge of (9287) Back Panel Assembly, measure 2" up from the floor and place EN71 Hand Rail so it is flush to the edge as shown in fig. 12.2. The bottom of the Handrail should be centered on (9054) Left Access. Pre-drill holes using a 1/8" Drill Bit then attach EN71 Hand Rail using 2 (WL3) 1/4 x 1-3/8" Wafer Lags (with flat washer). (fig. 12.1, 12.2 and 12.3)

Fig. 12.1

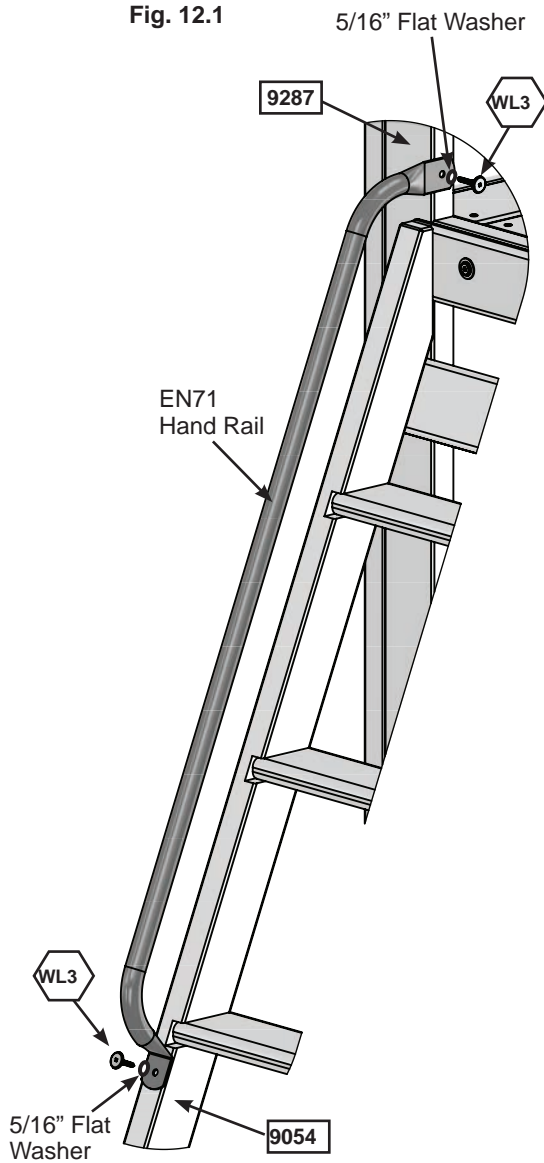

Fig.12.2

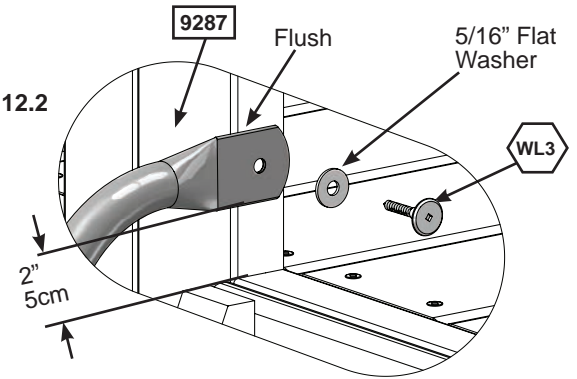
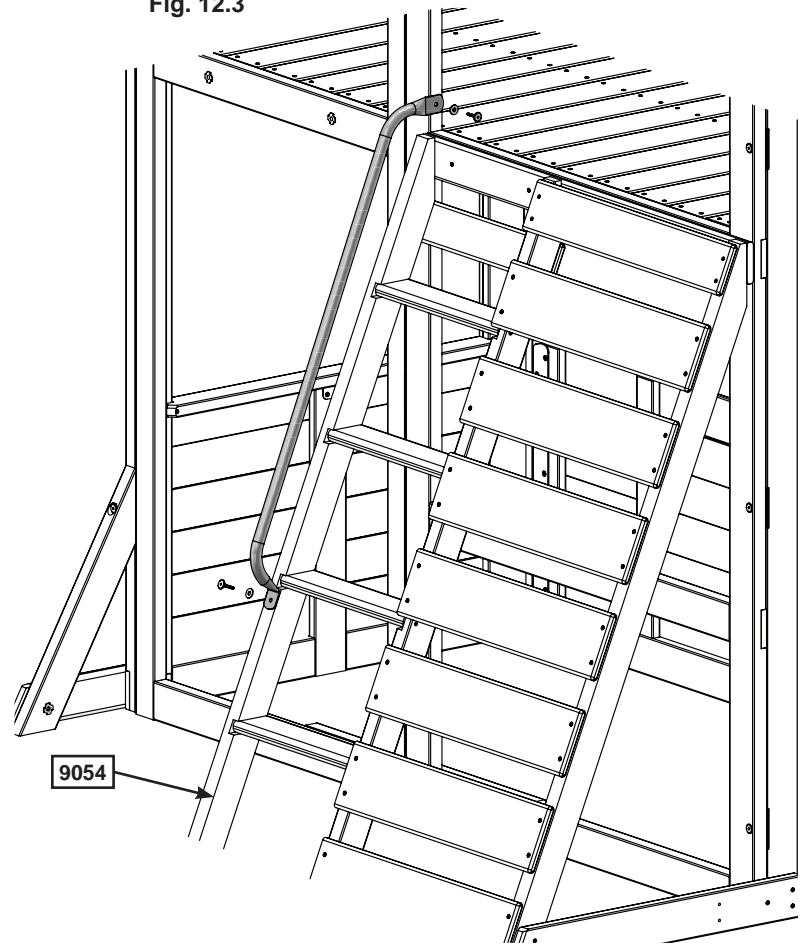

Fig. 12.3



Hardware

2 x  1/4 x 1-3/8" Wafer Lag (5/16" flat washer)

Other Parts

1 x EN71 Hand Rail

Step 12: Attach Steel Hand Grips and Handrail to Fort Part 2



B: Measure 6" from the top of (9543) Support Top and on (9287) Back Panel Assembly in the 2 places shown below, pre-drill with a 1/8" drill bit making sure holes are centered then attach 2 Steel Hand Grips with 2 (WL3) 1/4 x 1-3/8" Wafer Lag (with flat washer) per Steel Hand Grip. (fig.12.3)

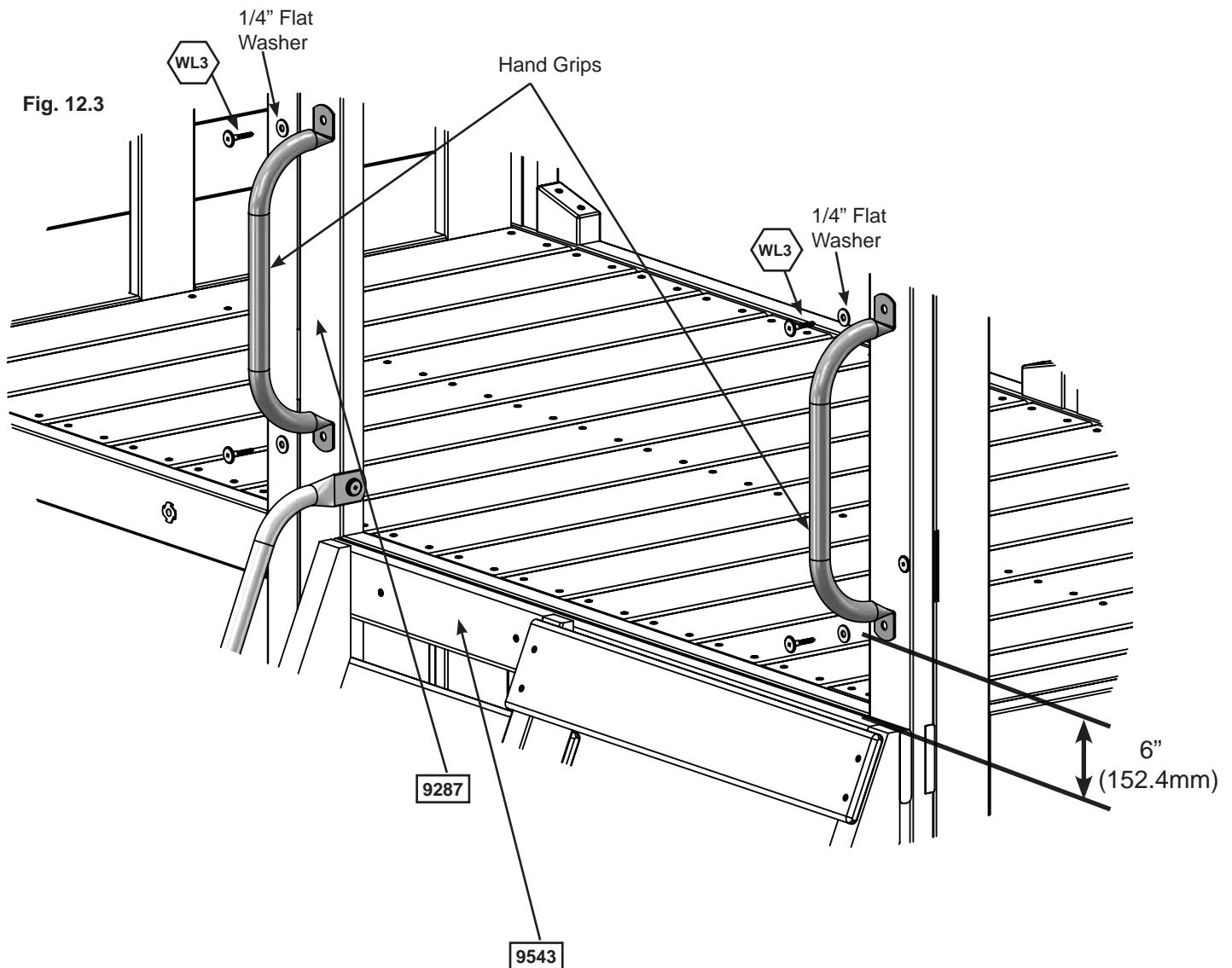

Hardware

4 x WL3 1/4 x 1-3/8" Wafer Lag (1/4" flat washer)

Other Parts

2 x Hand Grips

Step 13: Door Panel Assembly Part 1



A: On the inside of (2837) Door Window Panel measure 15" up from the bottom and attach Catch Plate flush to the edge using 2 (S38) #7 x 1-1/8" Pan Screws. (fig. 13.1 and 13.2)

B: On the inside of (2837) Door Window Panel measure 22" up from the bottom and attach 1 Door Handle using 2 (S37) #7 x 5/8" Pan Screws. (fig. 13.1 and 13.2)

Fig. 13.1
Inside View

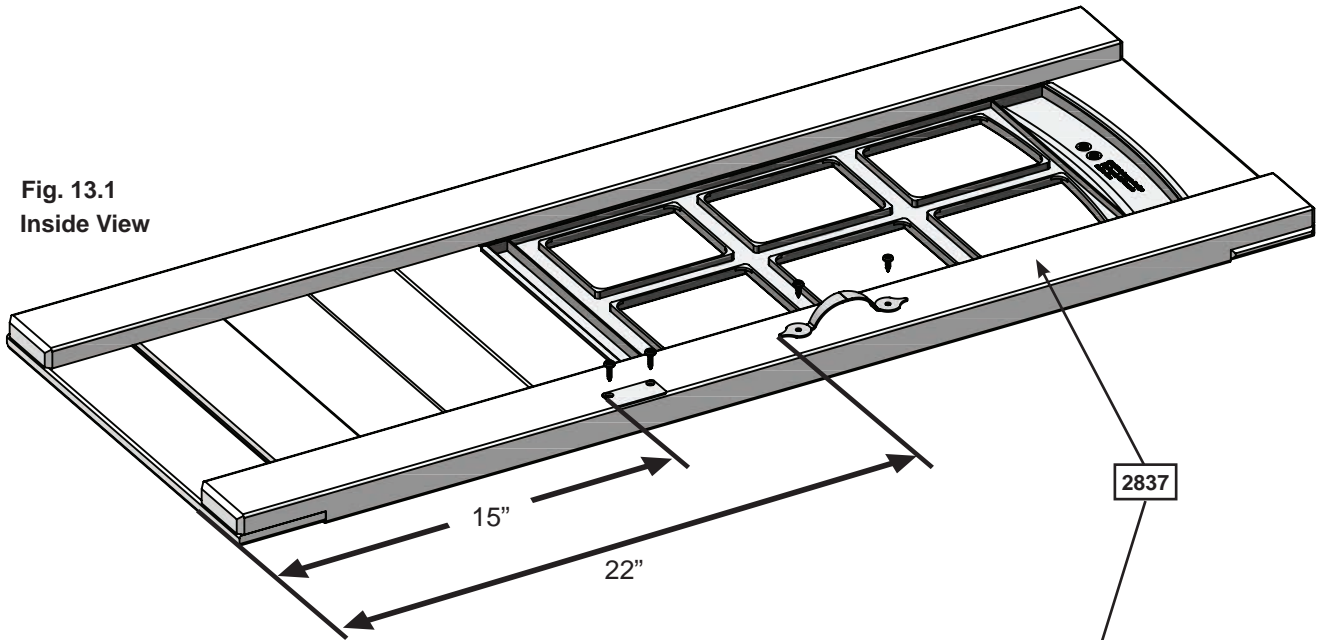
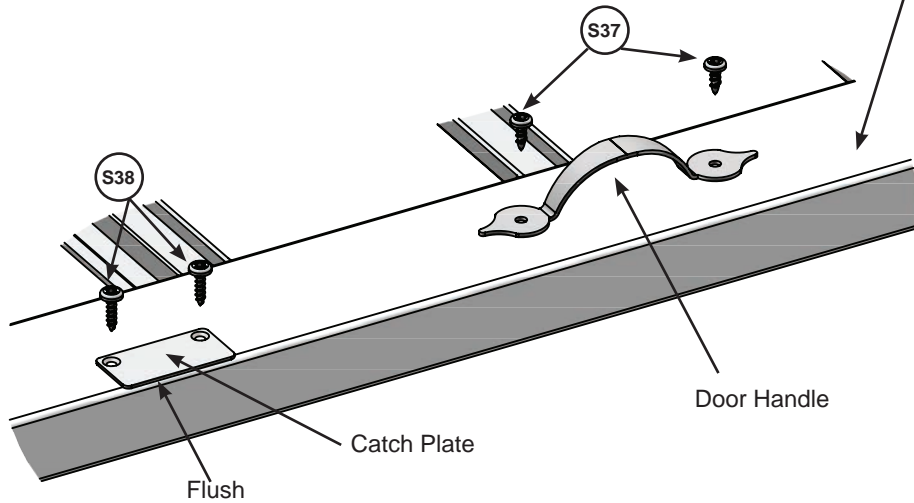

Fig. 13.2



Wood Parts

1 x 2837 Door Window Panel 1 1/4 x 15 3/4 x 42 1/8"

Hardware

2 x S38 #7 x 1-1/8" Pan Screw
2 x S37 #7 x 5/8" Pan Screw

Other Parts

1 x Door Handle
1 x Catch Plate

Step 13: Door Panel Assembly Part 2



C: On the outside of the (2837) Door Window Panel attach the second Door Handle at approximately the same place as the one on the inside. Use 2 (S37) #7 x 5/8" Pan Screws. (fig. 13.3)

D: Attach 2 Door Hinges on the outside of the (2837) Door Window Panel on the opposite side from the Door Handle. Judge spacing based on fig. 13.3. Use 3 (S37) #7 x 5/8" Pan Screws per Hinge.

Note: Hinge stops must be tight to (2837) Door Window Panel. (fig. 13.4)

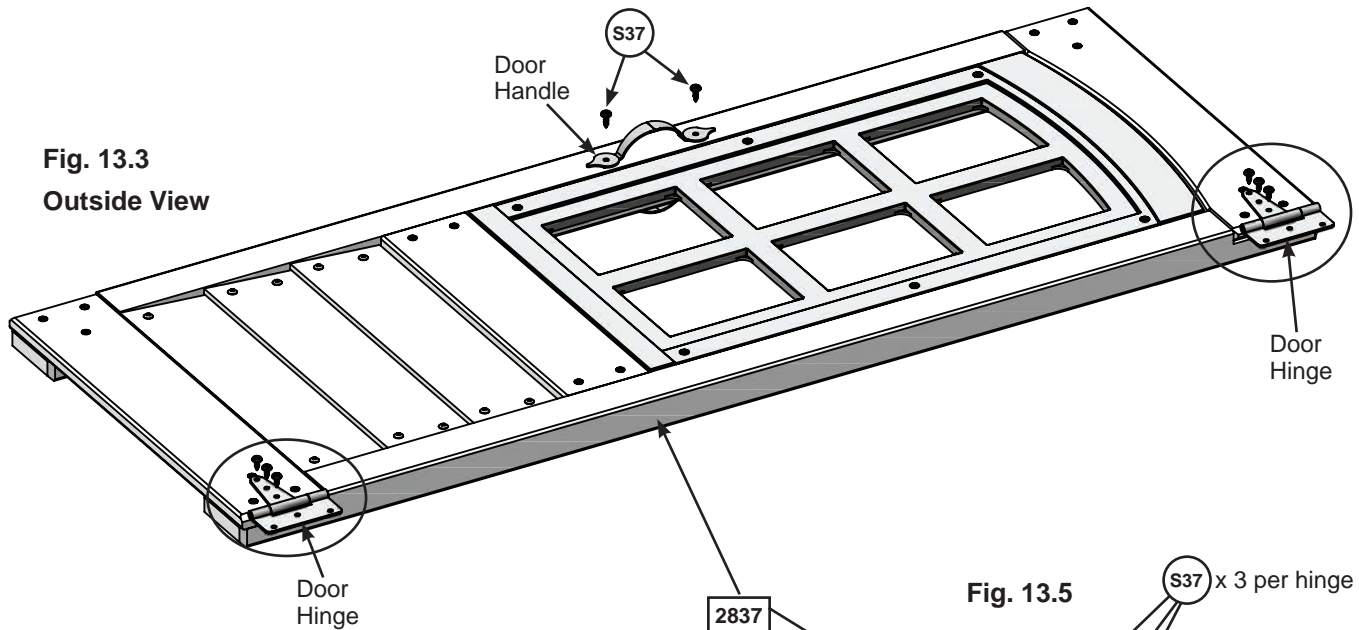

Fig. 13.3
Outside View

Fig. 13.4
Top View

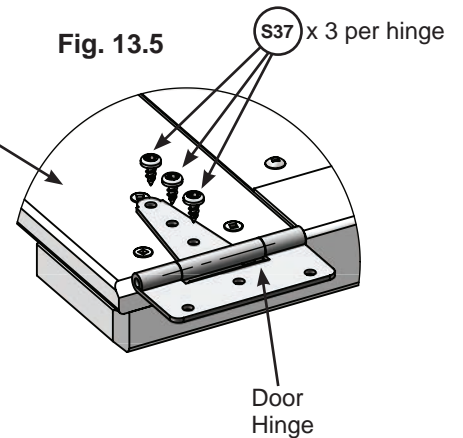
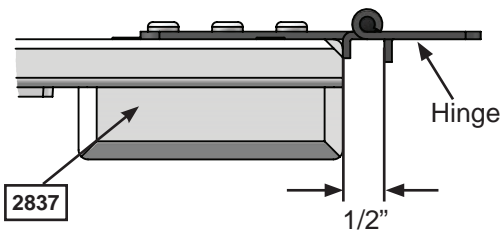

Fig. 13.5

Hardware
8 x #7 x 5/8" Pan Screw

Other Parts
1 x Door Handle
2 x Door Hinge

Step 13: Door Panel Assembly Part 3



E: In the opening for the door, measure 3/4" from the top of (9286) Front Panel Assembly and maximum 5/8" from right side of the opening which would be the Door Hinge side and attach the remaining side of the hinges to (9286) Front Panel Assembly using 3 (S37) #7 x 5/8" Pan Screws per hinge. (fig.13.6)

Fig. 13.6

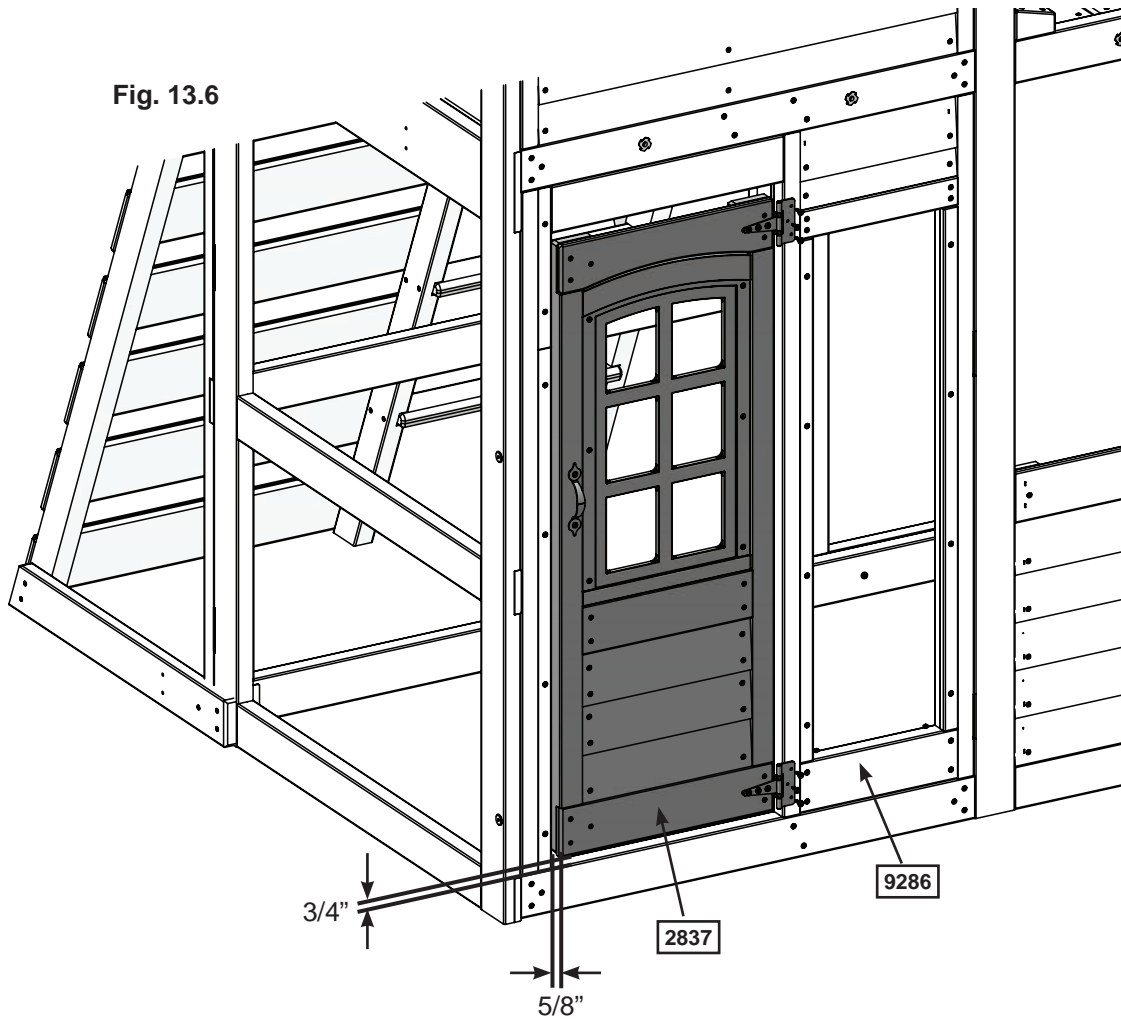
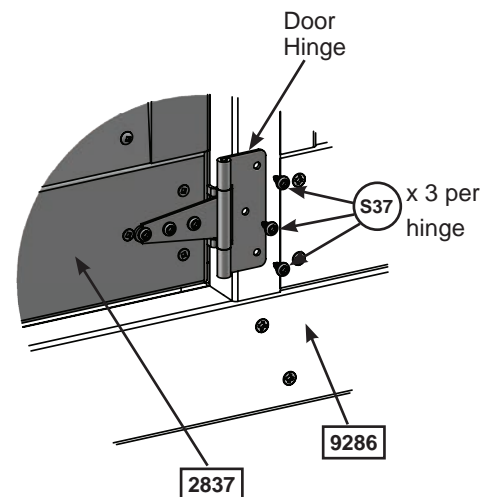



Fig. 13.7



Hardware

6 x  #7 x 5/8" Pan Screw

Step 13: Door Panel Assembly Part 4

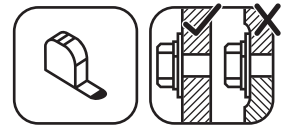

F: In the notched out opening of (2715) Door Stop attach the Magnetic Catch using 2 (S38) #7 x 1-1/8" Pan Screws. (fig. 13.8)

Important: Use a hand held screw driver and **DO NOT** over tighten.

G: On the inside of the assembly, attach (2715) Door Stop to (9286) Front Panel Assembly with 3 (S11) #8 x 2" Wood Screws, making sure (2715) Door Stop overhangs (9286) Front Panel Assembly by 1-1/4" and is in position to receive the Catch Plate.

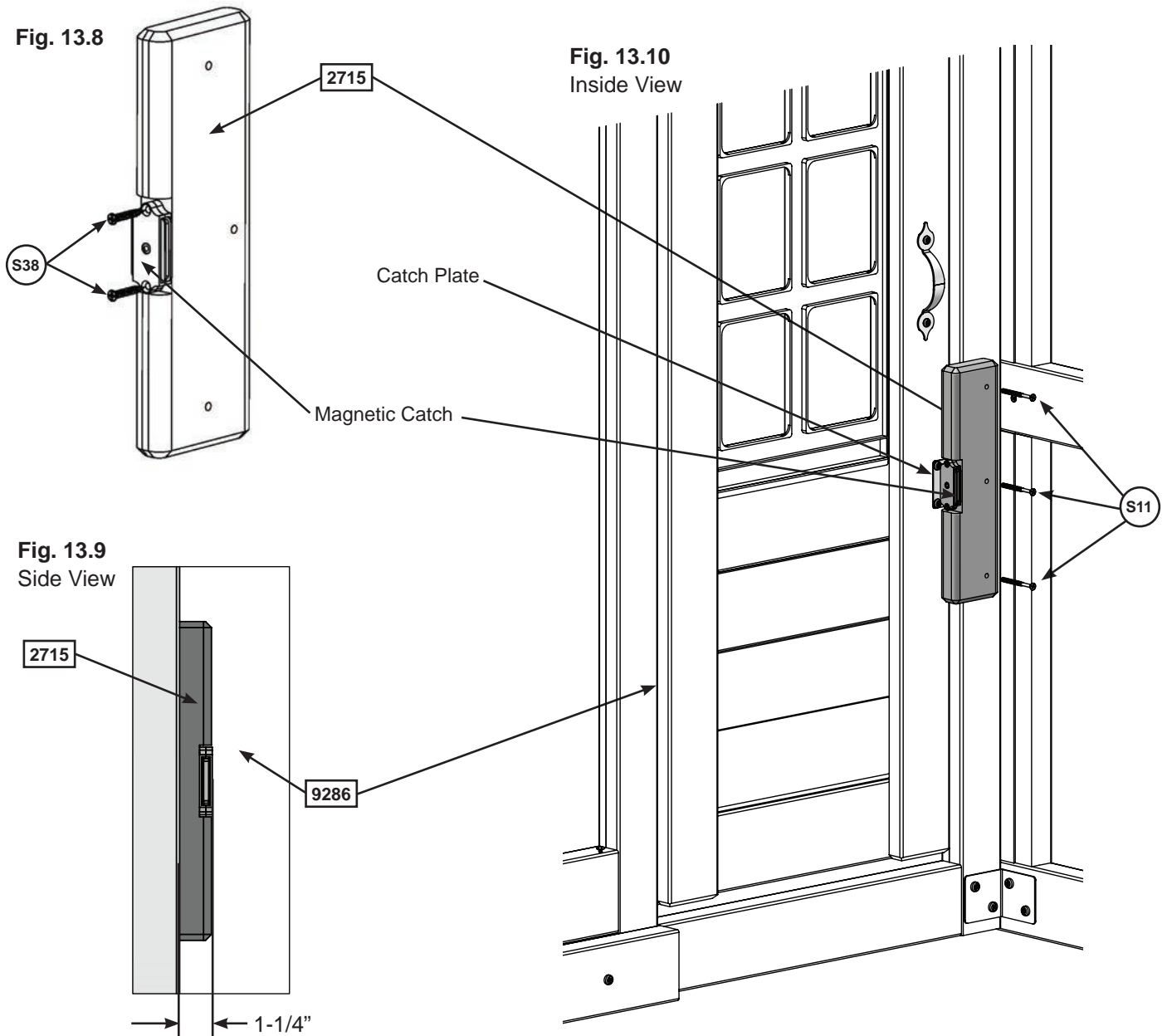

Wood Parts

1 x 2715 Door Stop 1 x 2 1/2 x 10"

Hardware

2 x S38 #7 x 1-1/8" Pan Screw
3 x S11 #8 x 2" Wood Screw

Other Parts

1 x Magnetic Catch

Step 14: Front Wall Assembly Part 1

A: Place (9539) Table Support flush to the notched of (2611) Table Top and attach with 4 (S7) #12 x 2" Pan Screws as shown in fig. 14.1.

B: Place Table Top Assembly in the center of opening and tight to (9286) Front Panel Assembly and attach (9539) Table Support to (9286) Front Panel Assembly with 2 (S3) #8 x 2-1/2" Wood Screws. (fig. 14.2 and 14.3)

Fig. 14.1

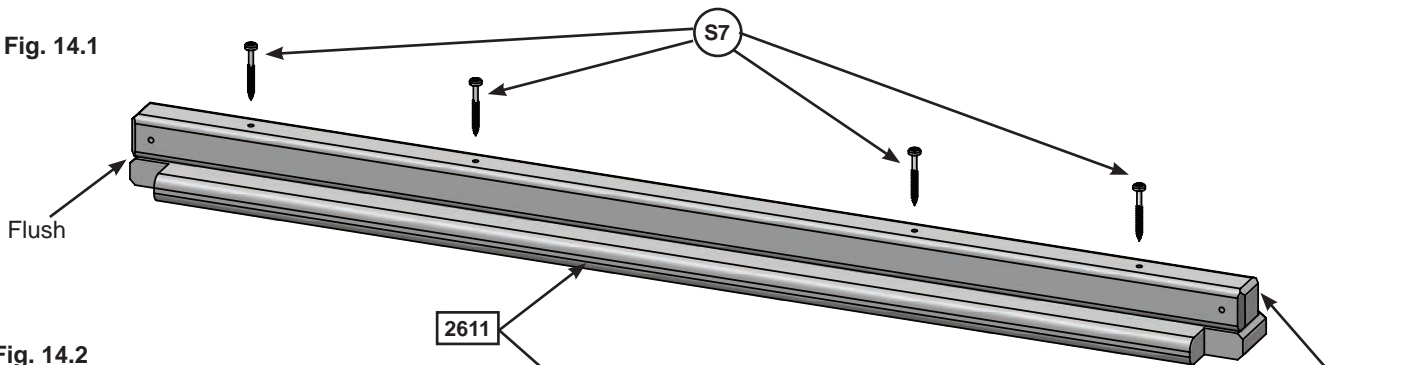

Fig. 14.2

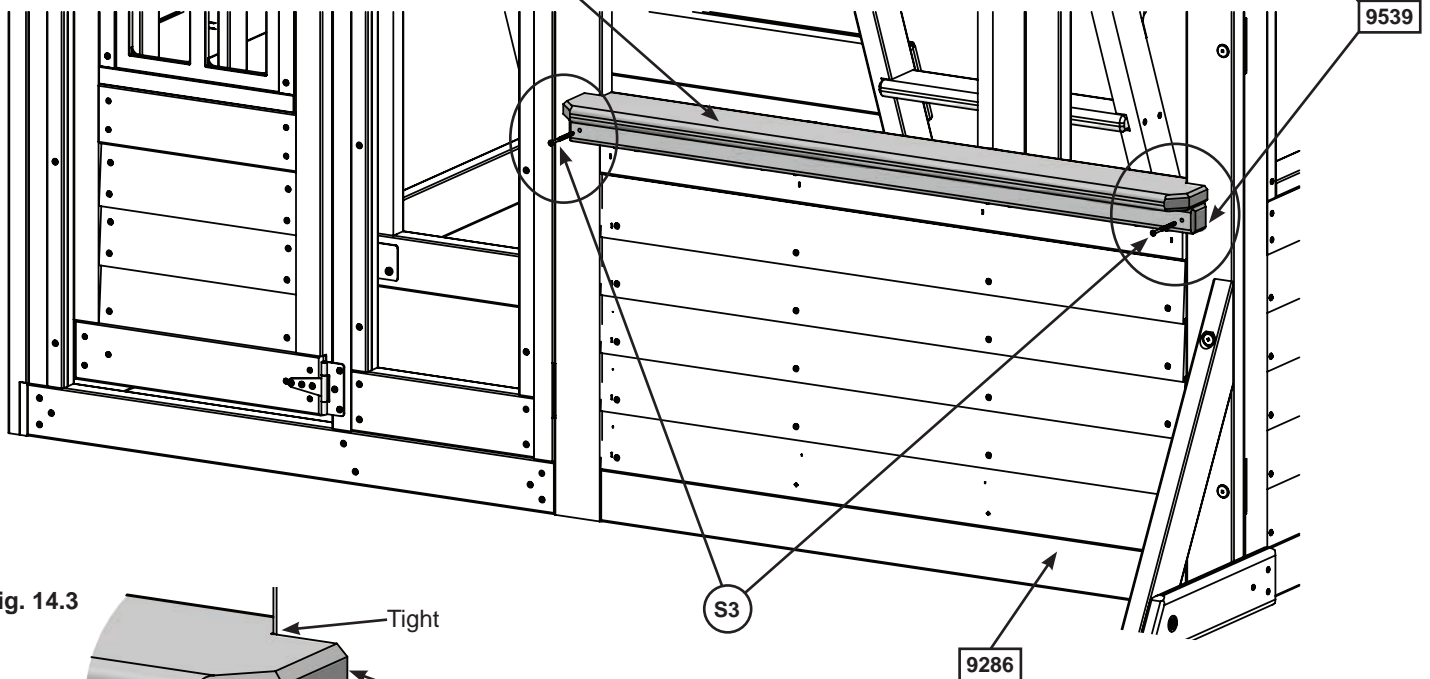
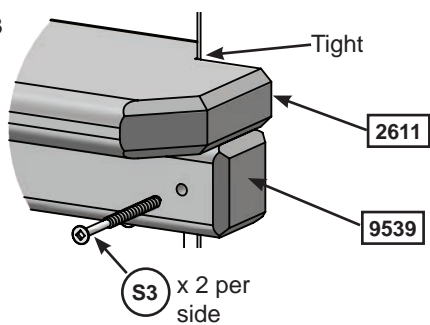

Fig. 14.3



Wood Parts

- 1 x 2611 Table Top 15/16 x 4 1/4 x 42 4/5"
- 1 x 9539 Table Support 1 1/4 x 1 1/4 x 39 5/8"

Hardware

- 4 x S7 #12 x 2" Pan Screw
- 2 x S3 #8 x 2-1/2" Wood Screw

Step 14: Front Wall Assembly Part 2

C: From the inside of the assembly attach (2611) Table Top to slats in (9286) Front Panel Assembly with 2 Flat Brackets using 3 (S37) #7 x 5/8" Pan Screws per bracket. (fig. 14.4, 14.5)

Fig. 14.4

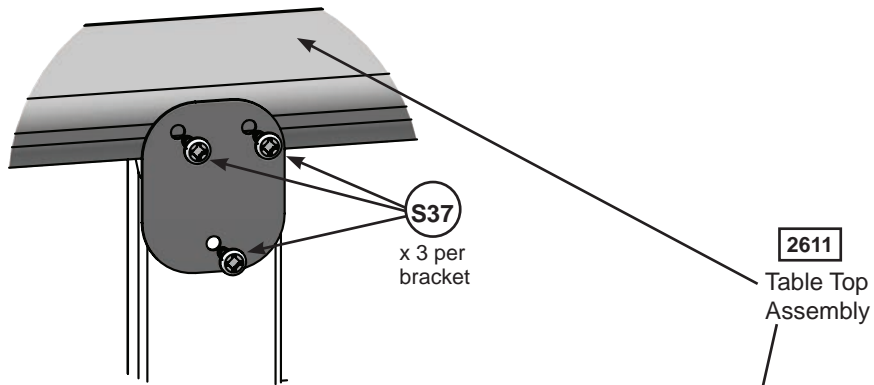
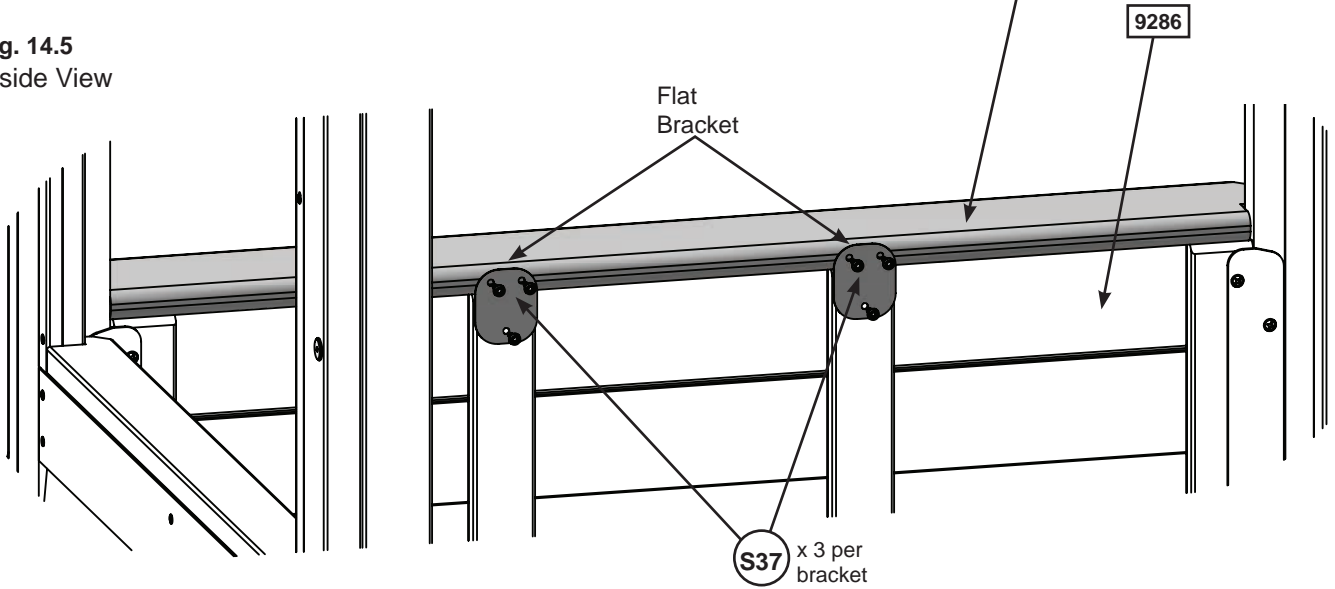



Fig. 14.5
Inside View



Hardware

6 x  #7 x 5/8" Pan Screw

Other Parts

2 x Flat Bracket

Step 15: Attach MOD SIDE Lite Part 1

D: From inside the assembly place MOD Side Lite into window opening in (9286) Front Panel Assembly as shown in fig. 15.1. Attach using 14 (S0) #8 x 7/8" Truss Screws.(Fig. 15.1 & 15.2)

Fig. 15.1
Inside View

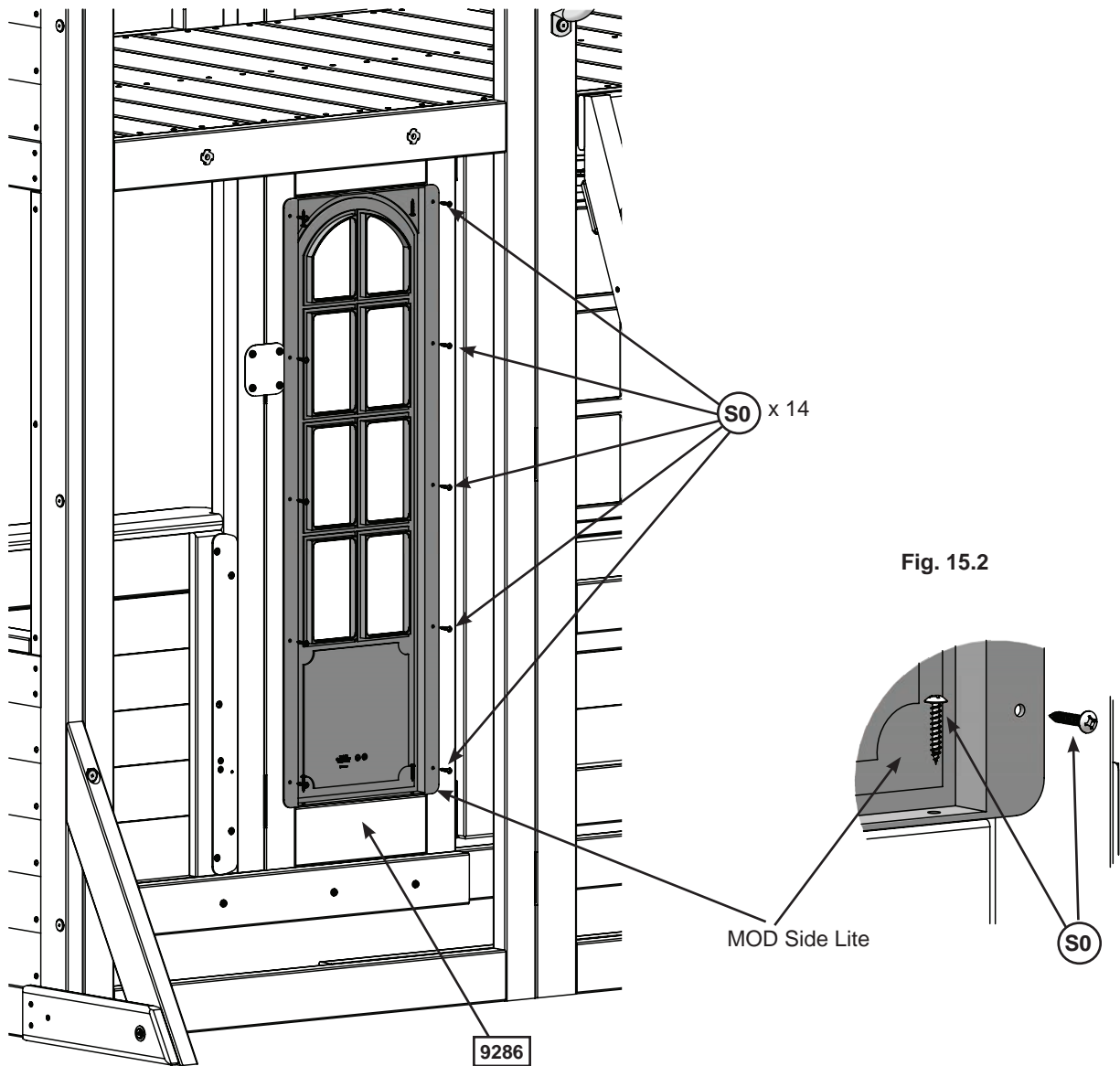

Hardware

14 x (S0) #8 x 7/8" Truss Screw

Other Parts

1 x MOD Side Lite

Step 15: Attach MOD SIDE Lite Part 2

E: From inside the assembly, place MOD4 Side Lite in the small upper opening and attach using 10 (S0) #8 x 7/8" Truss Screws. (Fig. 15.3 & 15.4)

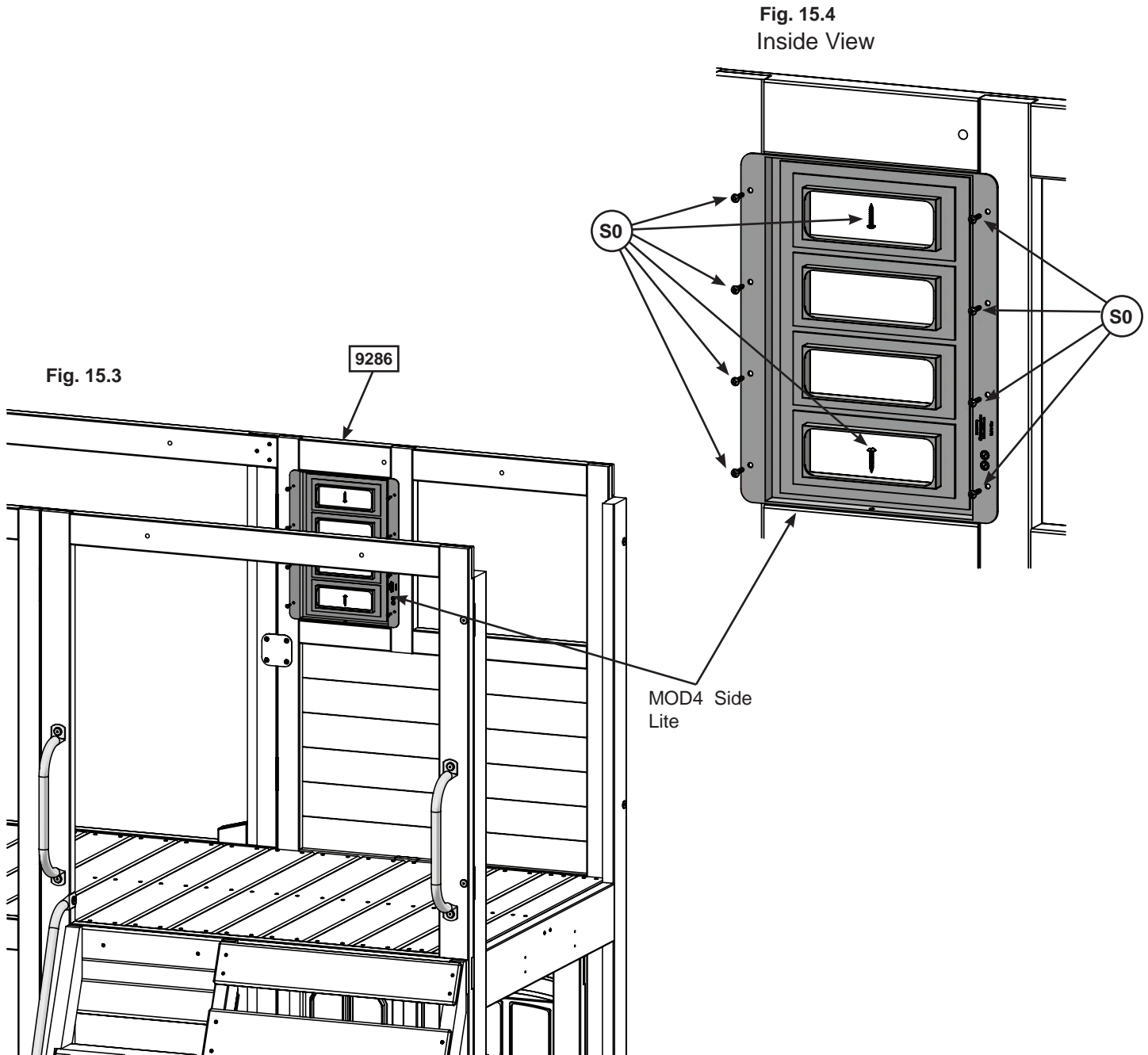

Hardware

10 x (S0) #8 x 7/8" Truss Screw

Other Parts

1 x MOD4 Side Lite

Step 16: Tic Tac Toe Assembly Part 1

A: Center the top of Tic Tac Toe assembly in the upper opening of the (9286) Front Panel Assembly so that it's flush to the inner edge. Attach using 3 (S0) #8 x 7/8" Truss Screws. (fig. 16.1)

B: Center Tic Toe Bottom on the inside edge of (9579) Playroom Bottom checking to make sure that it lines up with the Tic Tac Toe top piece. Attach using 3 (S0) #8 x 7/8" Truss Screws. (fig. 16.2)

C: Assemble the remaining Tic Tac Toe pieces as shown in fig. 16.2.

Fig. 16.1

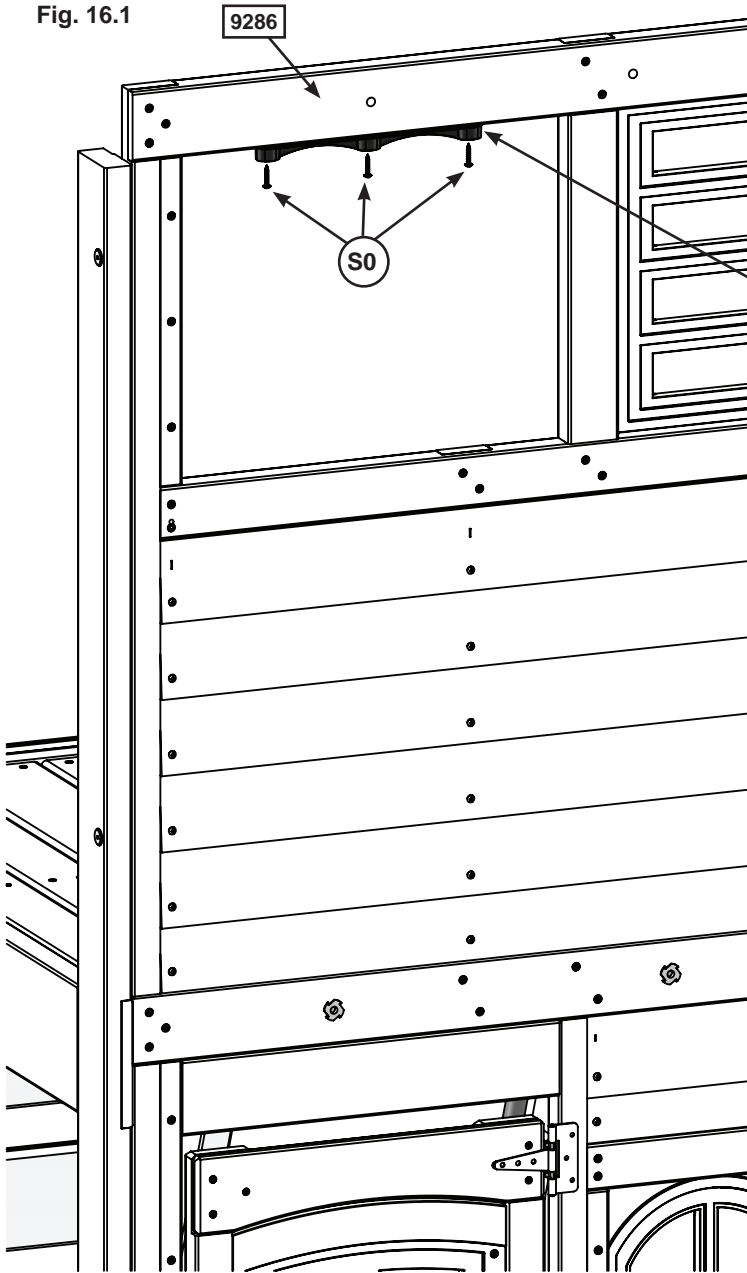
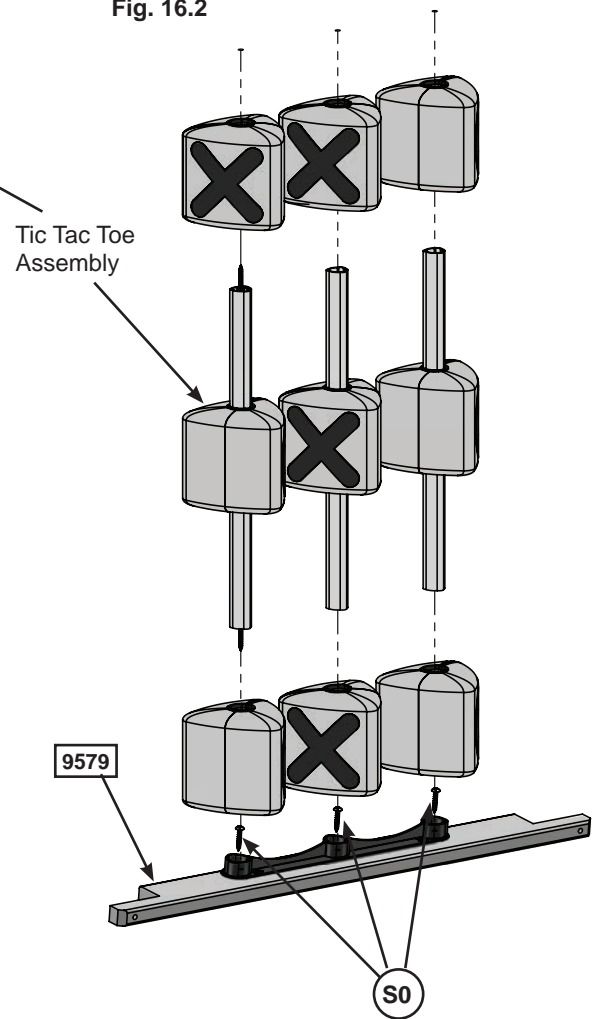

Fig. 16.2



Wood Parts

1 x 9579 Playroom Bottom 5/8 x 2 x 21 15/16"

Hardware

6 x S0 #8 x 7/8" Truss Screw

Other Parts

1 x Tic Tac Toe Assembly

Step 16: Tic Tac Toe Assembly Part 2

D: From outside the assembly, angle the Tic Tac Toe Assembly so that the three rows fit into the Tic Tac Toe assembly top and so (9579) Playroom Bottom fits into the bottom of the opening. (fig.16.3)

E: Attach (9579) Playroom Bottom to (9286) Front Panel Assembly using 2 (S11) #8 x 2" Wood Screws. (fig. 16.4, 16.5)

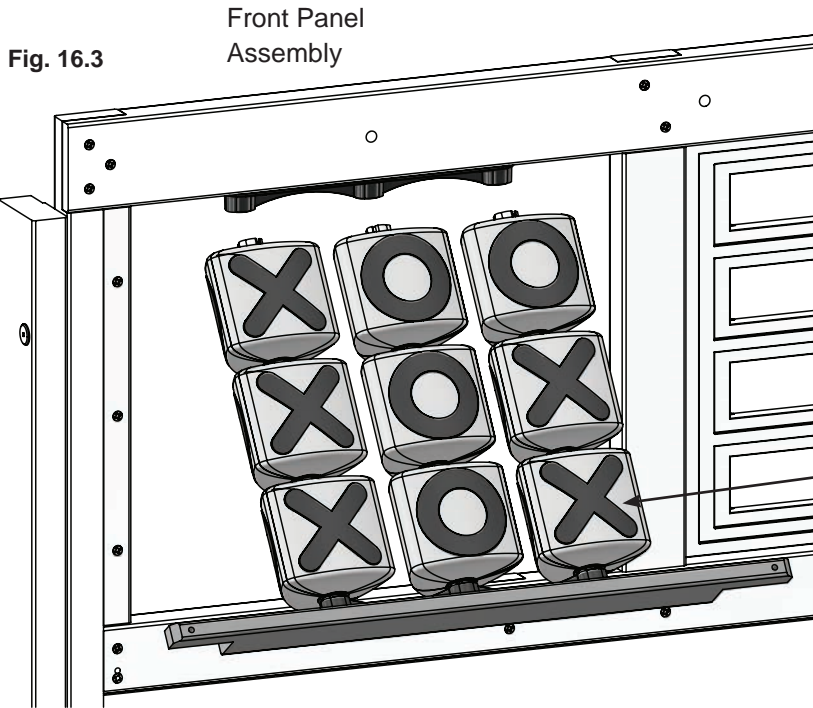
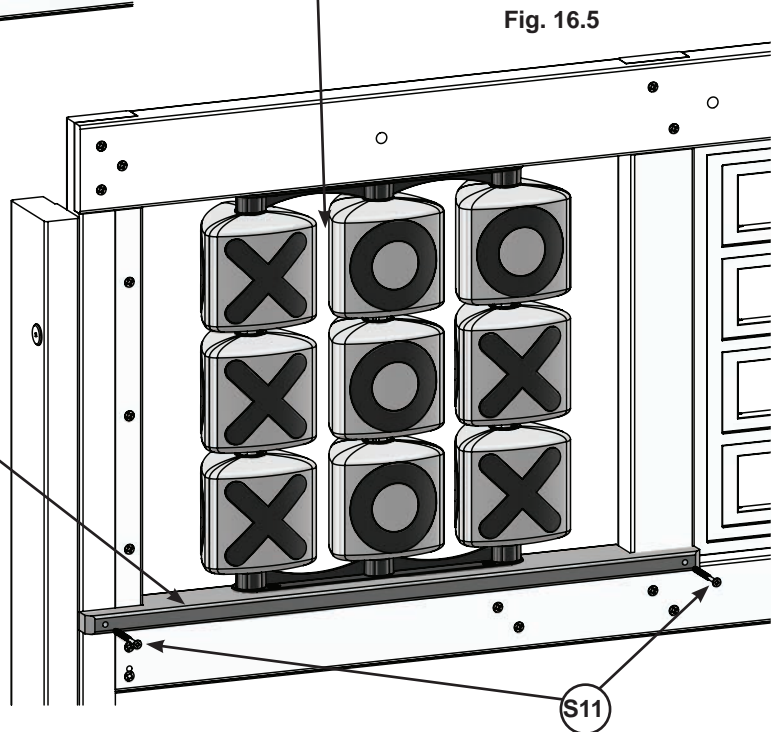
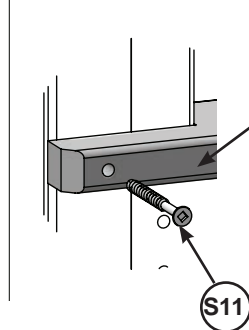

Fig. 16.4



Hardware

2 x (S11) #8 x 2" Wood Screw

Step 17: Swing Beam Assembly Part 1

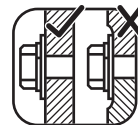

A: Attach 6 Heavy Duty Swing Hangers to (9049) Engineered SW Beam using 2 (G13) 5/16 x 6-1/8" Hex Bolt (with 4 flat washers, 2 plastic formed washer and 2 lock nut) per swing hanger, as shown in fig. 17.1 and 17.2.

B: Attach 1 Spring Loaded Quick Link to each Heavy Duty Swing Hanger. (fig. 17.3)

C: Install 1 (WB7) 5/16 x 3" Wafer Bolt (with flat washer and t-nut) in the middle bolt hole, from the bottom up, in (9049) Engineered SW Beam as shown in fig. 17.1 and 17.4. **IT IS IMPORTANT THAT THIS BOLT IS ATTACHED. IT WILL MINIMIZE CHECKING OF WOOD.**

D: Attach Cedar Summit by KidKraft Plaque to centre of (9049) Engineered SW Beam (over top of t-nut) using 4 (S38) #7 x 1-1/8" Pan Screws. (fig. 17.5)

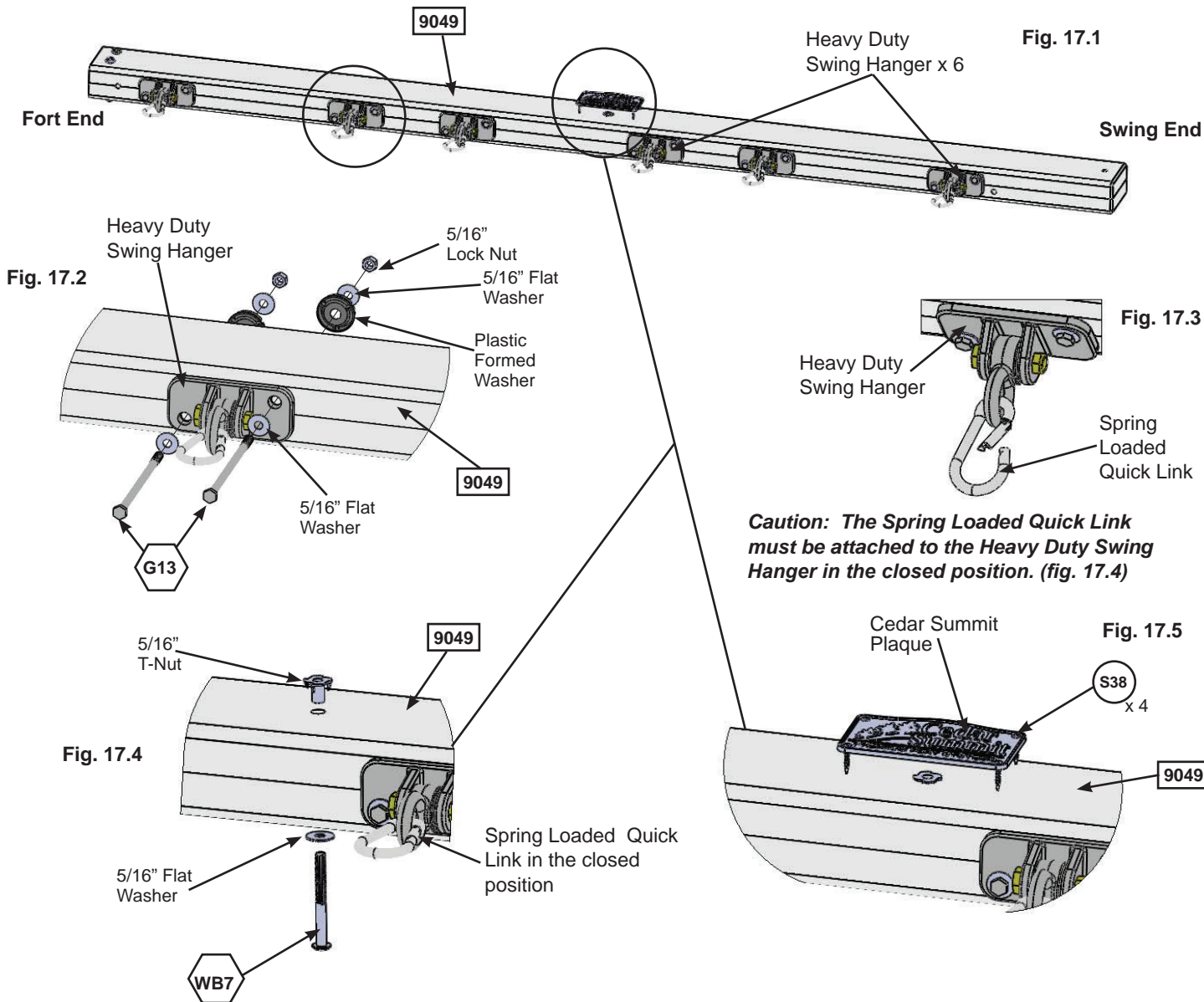

Caution: The Spring Loaded Quick Link must be attached to the Heavy Duty Swing Hanger in the closed position. (fig. 17.4)

Wood Parts	Hardware	Other Parts
1 x 9049 Engineered SW Beam 3 x 5 1/4 x 92"	12 x G13 5/16 x 6-1/8" Hex Bolt (5/16" flat washer x 2, 5/16" lock nut & plastic formed washer)	6 x Heavy Duty Swing Hangers
	1 x WB7 5/16 x 3" Wafer Bolt (5/16" flat washer, 5/16" t-nut)	6 x Spring Loaded Quick Link
	4 x S38 #7 x 1-1/8" Pan Screw	1 x Cedar Summit by KidKraft Plaque

Step 17: Swing Beam Assembly Part 2

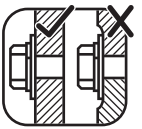

E: On the Fort End of (9049) Engineered SW Beam attach 2 Heavy Flat Brackets with 2 (G21) 5/16 x 3-3/4" Hex Bolts (with 4 flat washers and 2 lock nut). (fig. 17.6 and 17.7)

F: Place (9069) SW Mount in between both Heavy Flat Brackets and place 1 Heavy L-Bracket against (9049) Engineered SW Beam and (9069) SW Mount. Attach with 1 (G17) 3/8 x 6" Hex Bolt (with 2 flat washers, plastic formed washer and lock nut). (fig. 17.8)

G: Attach (9069) SW Mount to Heavy Flat Brackets with 2 (G21) 5/16 x 3-3/4" Hex Bolts (with 4 flat washers and 2 lock nut). (fig. 17.9)

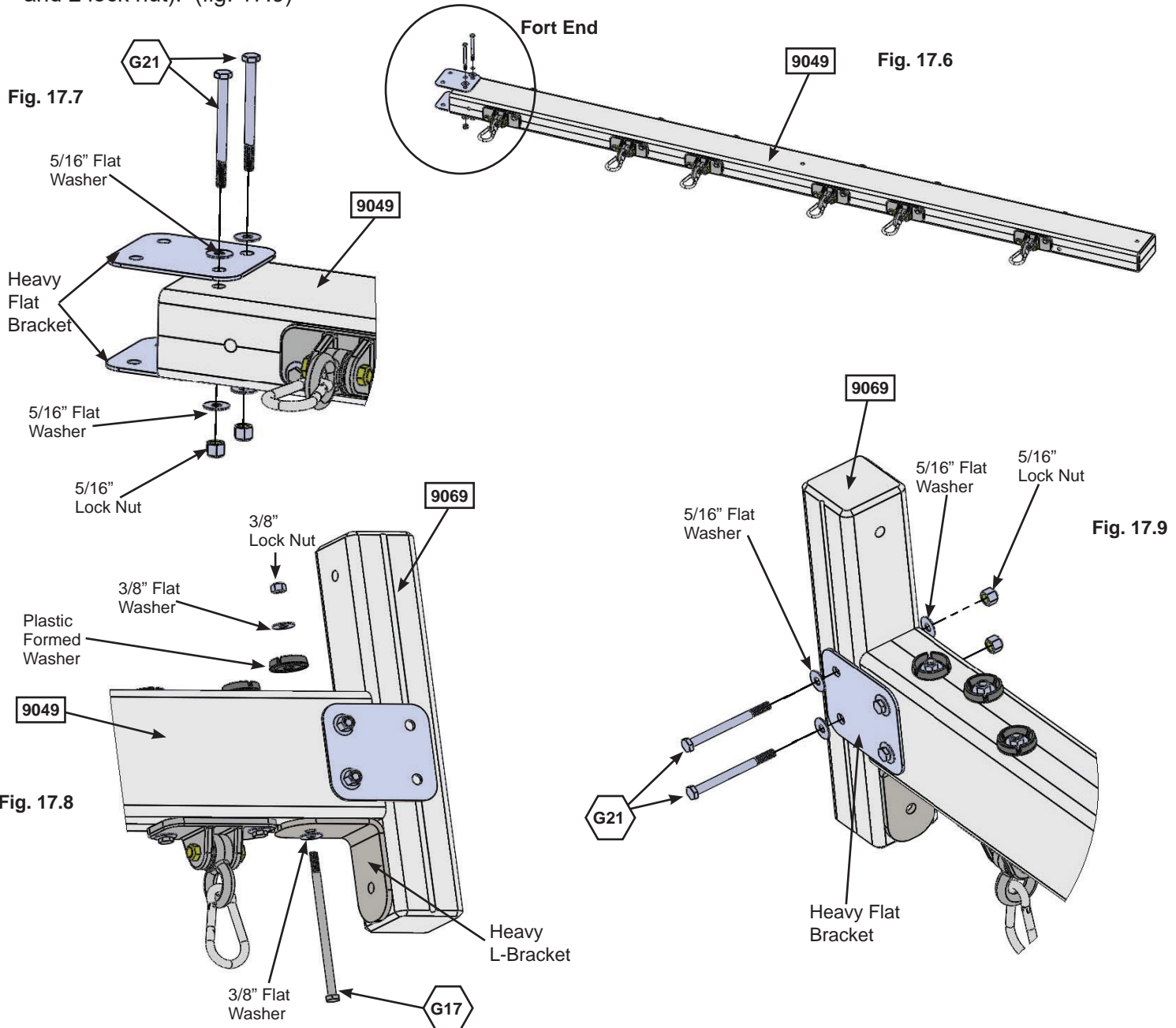

Wood Parts

1 x 9069 SW Mount 3 x 3 x 16"

Hardware

4 x G21 5/16 x 3-3/4" Hex Bolt
(5/16" flat washer x 2, 5/16" lock nut)

1 x G17 3/8 x 6" Hex Bolt
(3/8" flat washer x 2, plastic formed washer & 3/8" lock nut)

Other Parts

2 x Heavy Flat Bracket
1 x Heavy L-Bracket

Step 18: Swing Post Assembly Part 1

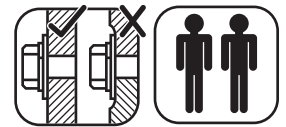

Note: Keep all bolts from Step 18 series loose until start of Step 20

A: Place (9068) SW Block Angle on top of (8507) Block SW and attach 2 Heavy L-Brackets on top of (9068) SW Block Angle feeding 2 (G17) 3/8 x 6" Hex Bolts (with 4 flat washers, 2 plastic formed washer and 2 lock nut) through both boards as shown in fig. 18.1 and 18.2.

B: Attach 3 (WB7) 5/16 x 3" Wafer Bolts (with flat washer and t-nut) to all three holes in each (9070) SW Post as shown in fig. 18.3. **IMPORTANT! MAKE SURE ALL 6 BOLTS ARE ATTACHED TO MINIMIZE CHECKING OF WOOD.**

C: Place (9068) SW Block Angle and (8507) Block SW assembly in between 2 (9070) SW Post (Heavy L-Brackets towards the outside). Place 1 Heavy C-Bracket on the top (9070) SW Post and attach with (G26) 3/8 x 9-1/4" Hex Bolt (with 2 flat washers and 1 lock nut), as shown in fig. 18.4

Fig. 18.1
Bottom View

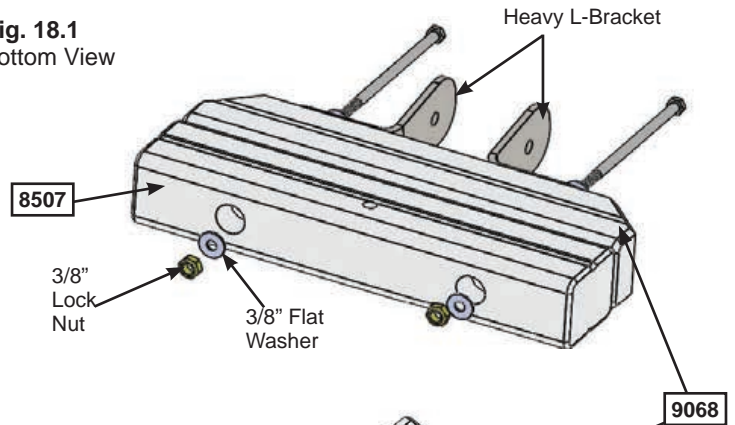

Fig. 18.2
Top View

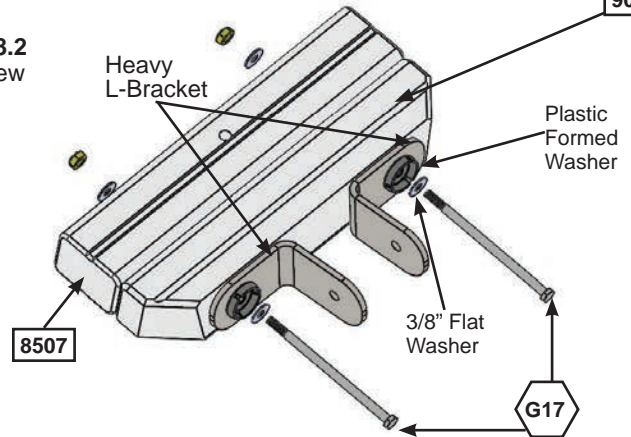

Fig. 18.4

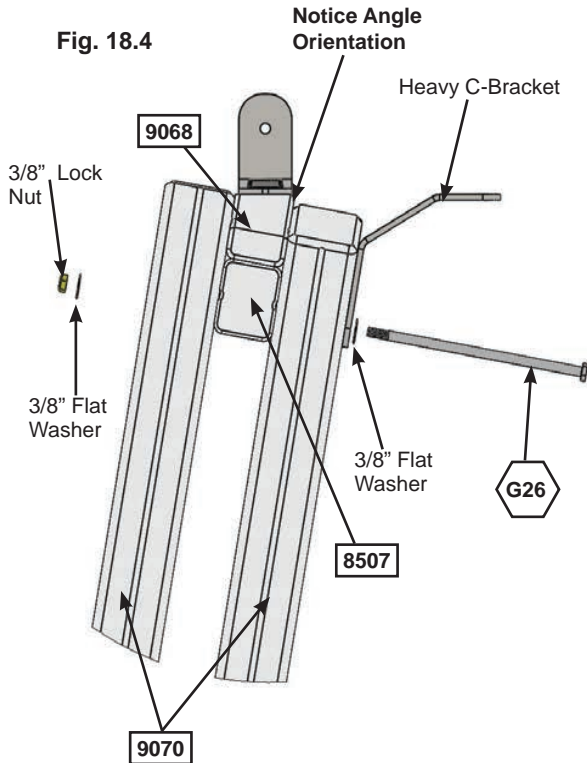
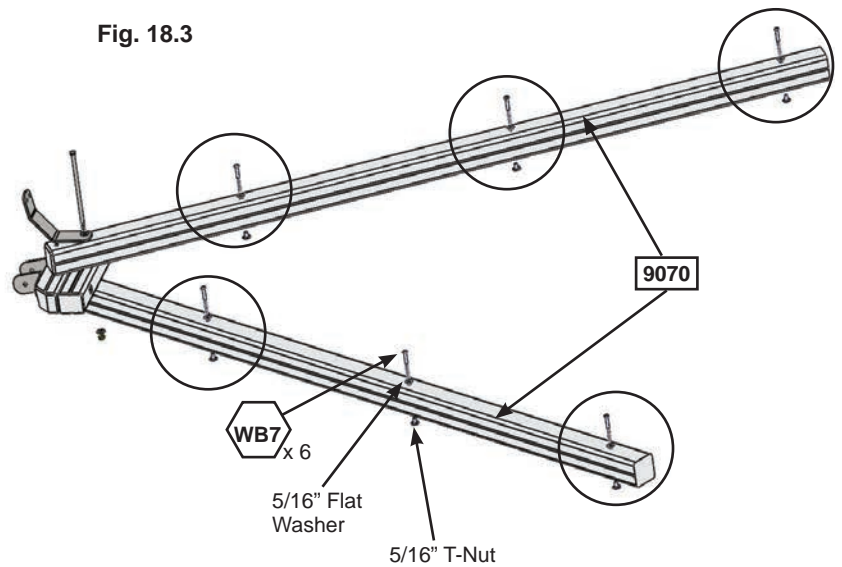

Fig. 18.3



Wood Parts

- 1 x [9068] SW Block Angle 2 1/2 x 3 x 15"
- 1 x [8507] Block SW 2-1/2 x 3 x 15"
- 2 x [9070] SW Post 3 x 3 x 92"

Hardware

- 2 x [G17] 3/8 x 6" Hex Bolt (3/8" flat washer x 2, plastic formed washer & 3/8" lock nut)
- 1 x [G26] 3/8 x 9-1/4" Hex Bolt (3/8" flat washer x 2 & 3/8" lock nut)
- 6 x [WB7] 5/16 x 3" Wafer Bolt (5/16" flat washer & 5/16" t-nut)

Other Parts

- 2 x Heavy L-Bracket
- 1 x Heavy C-Bracket



Step 18: Swing Post Assembly Part 2

D: Place Swing End of (9049) Engineered SW Beam in between Heavy L-Brackets assembled in Step 18 Part 1 making sure holes are lined up then attach Swing Post Assembly to Swing Beam Assembly using 1 (G20) 3/8 x 4" Hex Bolt (with 2 flat washers and lock nut) through Heavy L-Bracket. (fig. 18.5)

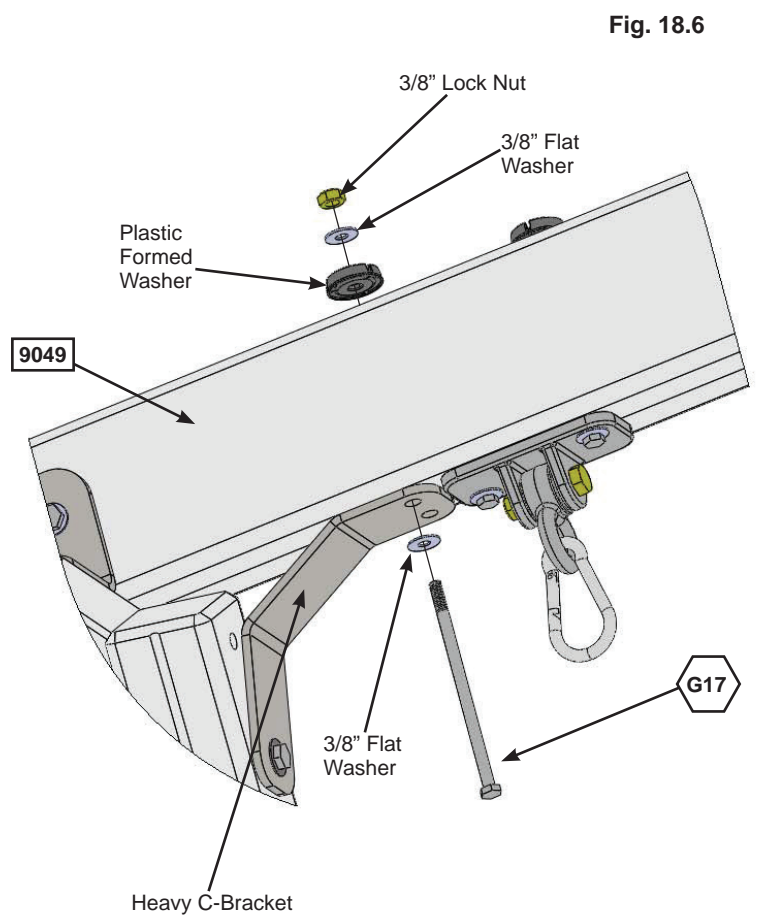
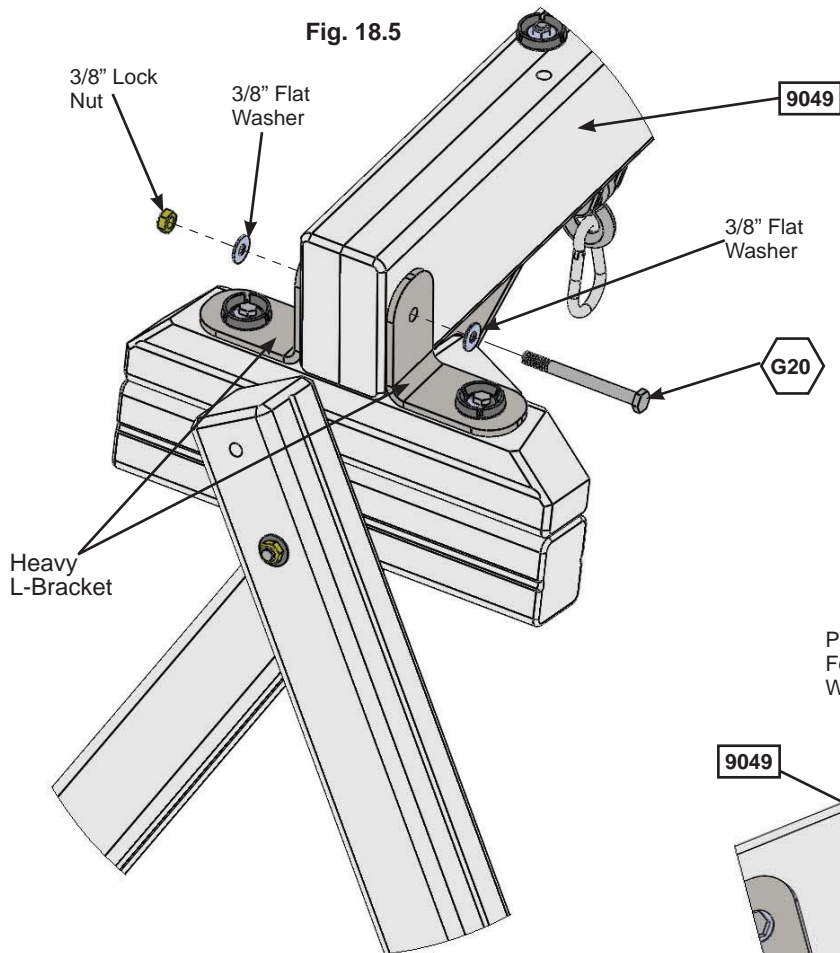
E: Attach (9049) Engineered SW Beam to Heavy C-Bracket with 1 (G17) 3/8 x 6" Hex Bolt (with 2 flat washers, plastic formed washer and lock nut). (fig. 18.6)



Hardware

- 1 x  3/8 x 6" Hex Bolt
(3/8" flat washer x 2, plastic formed washer & 3/8" lock nut)
- 1 x  3/8 x 4" Hex Bolt
(3/8" flat washer x 2 & 3/8" lock nut)

Step 18: Swing Post Assembly Part 3

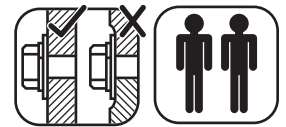

F: Place (9069) SW Mount flush to the top of SW Wall Panel. Attach with 1 (G5) 5/16 x 4-1/2" Hex Bolt (with lock washer, flat washer and t-nut) in the bottom hole from outside the assembly and 1 (G5) 5/16 x 4-1/2" Hex Bolt (with 2 x flat washer and 1 lock nut) in the top hole from inside the assembly. (fig. 18.7 and 18.8)

Fig. 18.7

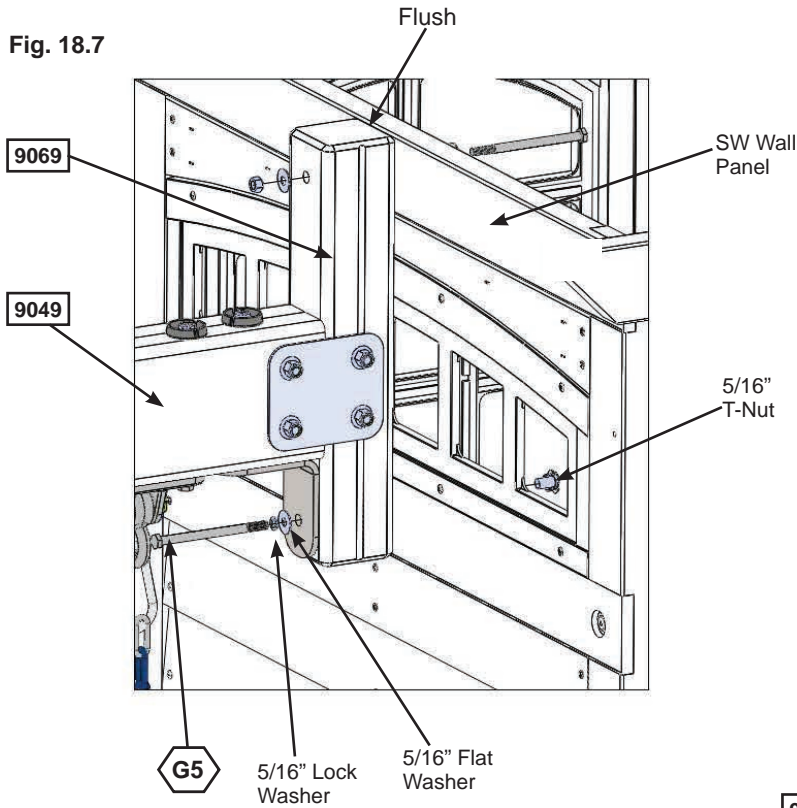
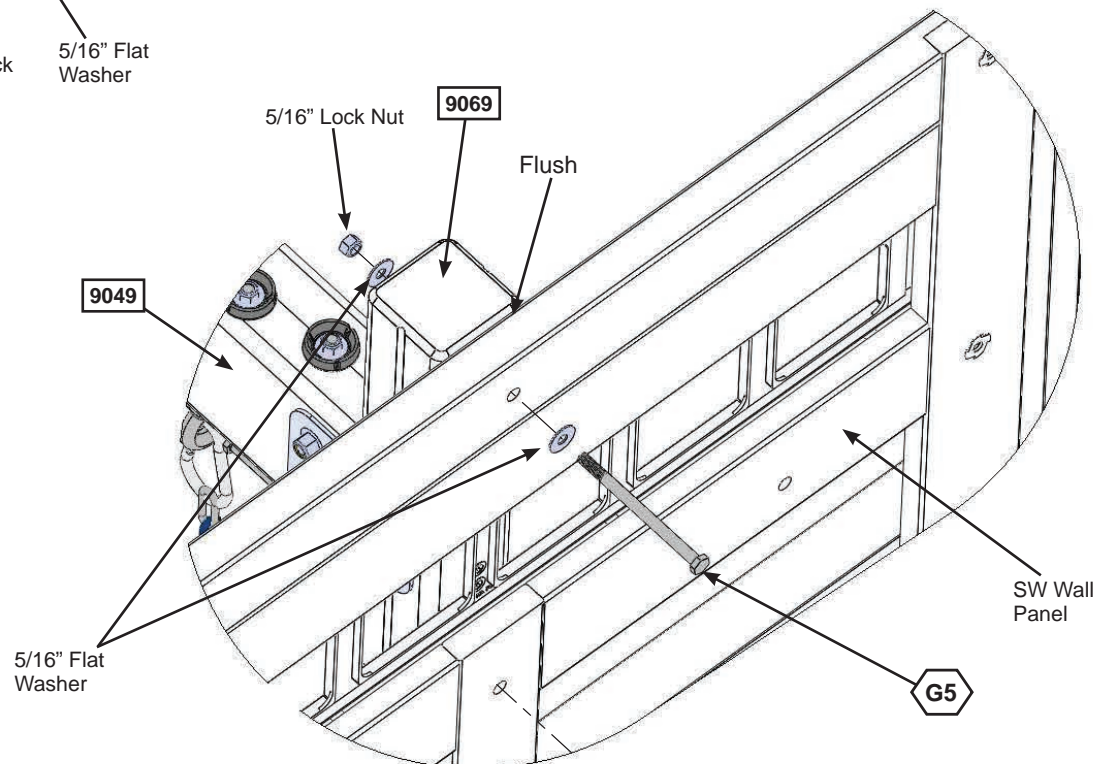



Fig. 18.8



Hardware

- 2 x  5/16 x 4-1/2" Hex Bolt
 (1 - 5/16" lock washer, 5/16" flat washer, 5/16" t-nut)
 (1 - 5/16" flat washer x 2, 5/16" lock nut)

Step 19: Attach Cross Support

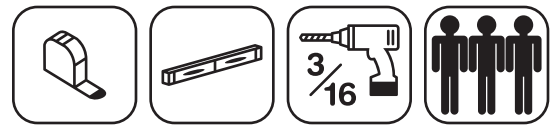

Pre-drill all holes using a 3/16" drill bit before installing the lag screws.

A: To adjust for uneven ground, raise or lower the (9067) Support Cross on the (9070) SW Post. Make sure the Support Cross is level prior to attaching with the lag screws. (fig. 19.1 and 19.2)

B: Place (9067) Support Cross between (9070) SW Posts at the previously determined spot and fasten with 1 (LS9) 5/16 x 4-3/4" Lag Screw (with flat washer) per side. (fig. 19.2 and 19.3) **Notice one side is fastened on the outside and one on the inside. It is important that each side is positioned exactly the same as the diagram. (fig. 19.3) Tighten the lag screw when you are sure (191) Support Cross is level.**

C: Attach 1 (WB8) 5/16 x 2-3/8" Wafer Bolt (with flat washer and t-nut) to (9067) Support Cross through the middle hole. (fig. 19.2 and 19.3) **IMPORTANT! MAKE SURE THE BOLT IS ATTACHED TO MINIMIZE CHECKING OF WOOD.**

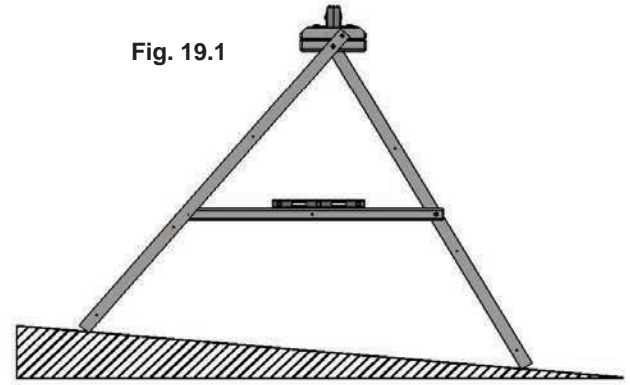

Fig. 19.1

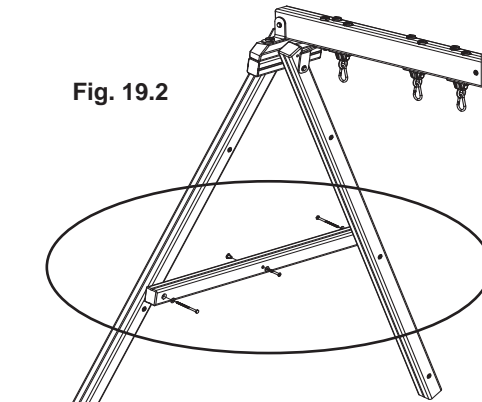

Fig. 19.2

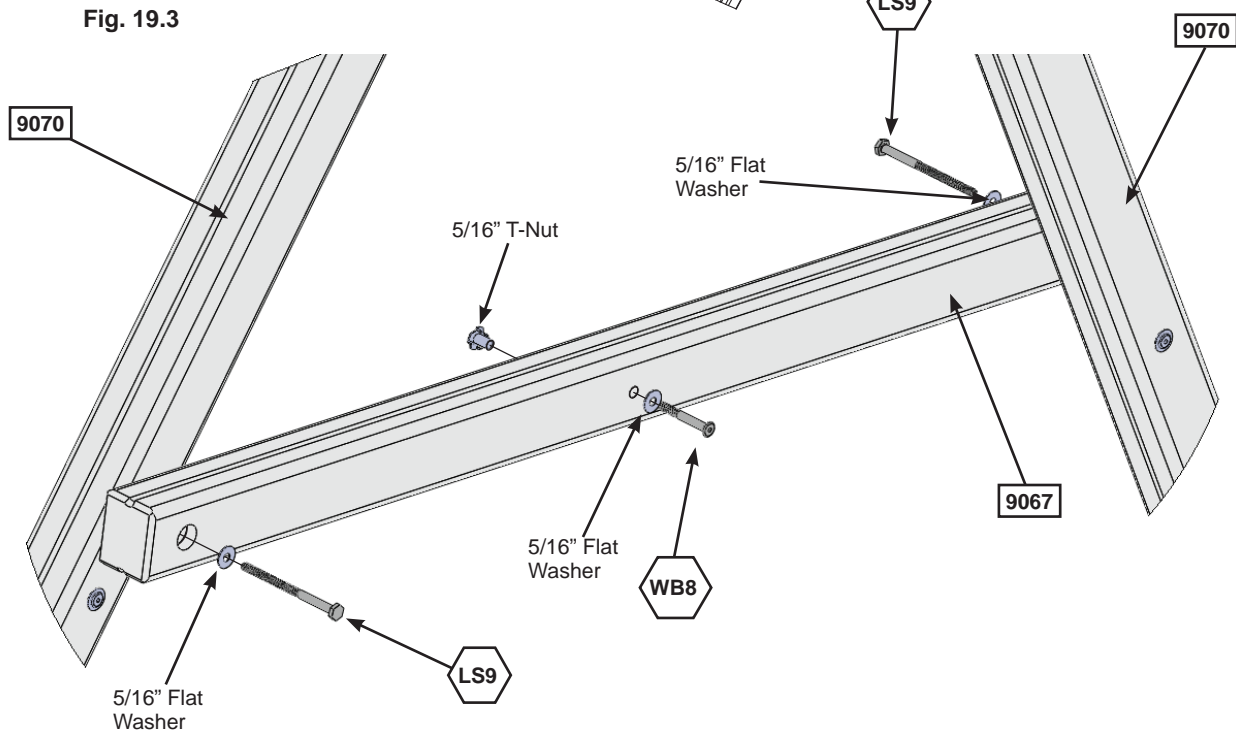

Fig. 19.3

Wood Parts

1 x 9067 Support Cross 2 1/2 x 3 x 51"

Hardware

2 x LS9 5/16 x 4-3/4" Lag Screw (5/16" flat washer)

1 x WB8 5/16 x 2-3/8" Wafer Bolt (5/16" flat washer, 5/16" t-nut)

Step 20: Final Swing Post Assembly

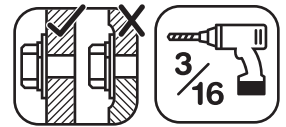

Pre-drill all holes using a 3/16" drill bit before installing the lag screws.

Note: Tighten all bolts from Step 18 series before installing lag screws.

A: Attach 1 (LS9) 5/16 x 4-3/4" Lag Screw (with flat washer) into each (9070) SW Post, as shown in fig. 20.1.

B: Attach 1 (LS9) 5/16 x 4-3/4" Lag Screw (with flat washer) into remaining hole of the Heavy C-Bracket into (9049) Engineered SW Beam. (fig. 20.1)

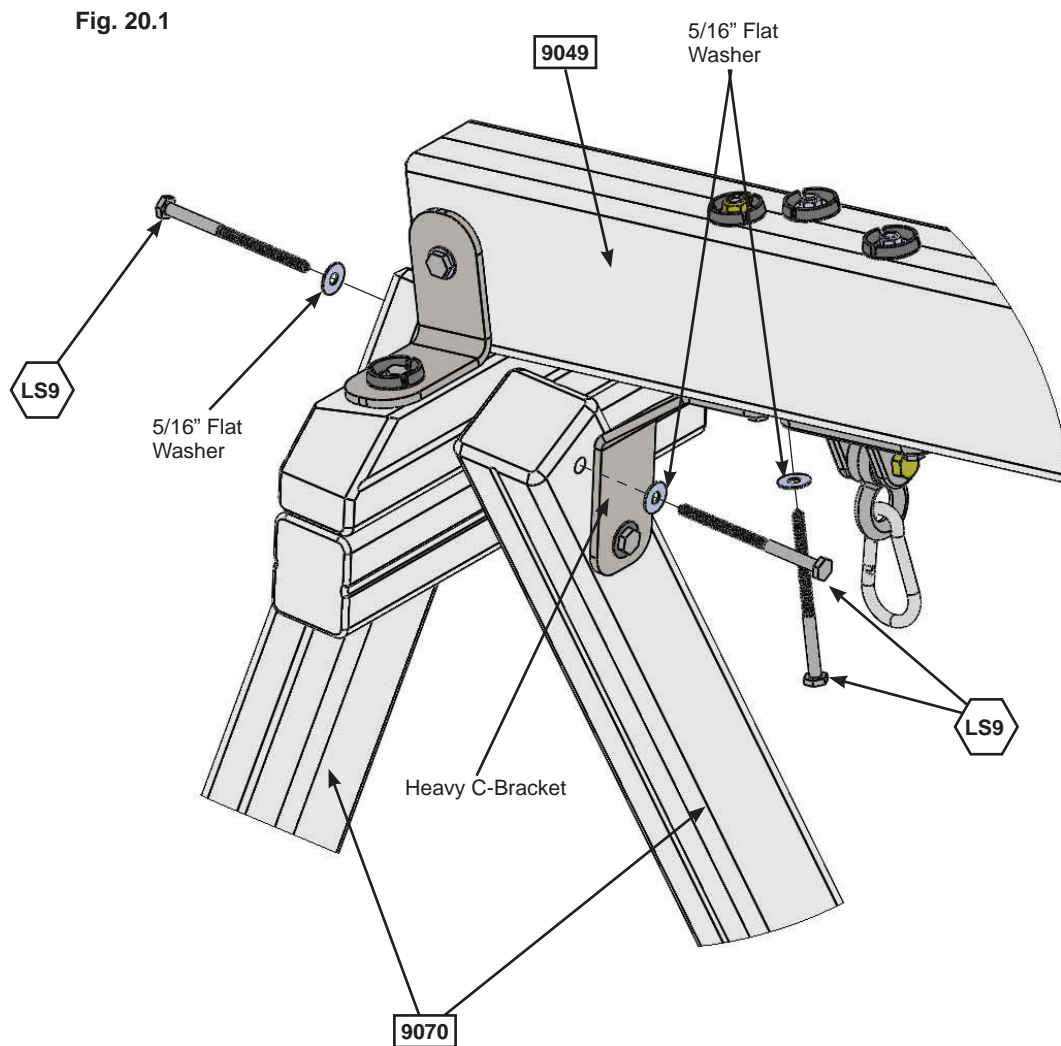

Hardware

3 x  5/16 x 4-3/4" Lag Screw
(5/16" flat washer)

Step 21: Install Ground Stakes

MOVE FORT TO FINAL LOCATION PRIOR TO STAKING

FINAL LOCATION MUST BE LEVEL GROUND

A: In the 5 places shown in fig. 21.1 drive the Rebar Ground Stakes 13" into the ground against both (2606) SW Ground, (9287) Back Panel Assembly and both (9070) SW Post. Be careful not to hit the washer while hammering stakes into the ground as this could cause the washer to break off. (fig. 21.1)

B: Attach ground stakes using 1 (S7) #12 x 2" Pan Screw per ground stake as shown in (fig. 21.1 & 21.2)

C: After driving stakes into the ground, check for sharp edges caused by the impact of the hammer. Smooth any sharp edges from impact area and touch up with outdoor paint.

⚠ Warning! To prevent tipping and avoid potential injury, stakes must be driven 13" into ground. Digging or driving stakes can be dangerous if you do not check first for under-ground wiring, cables or gas lines.

Fig. 21.1

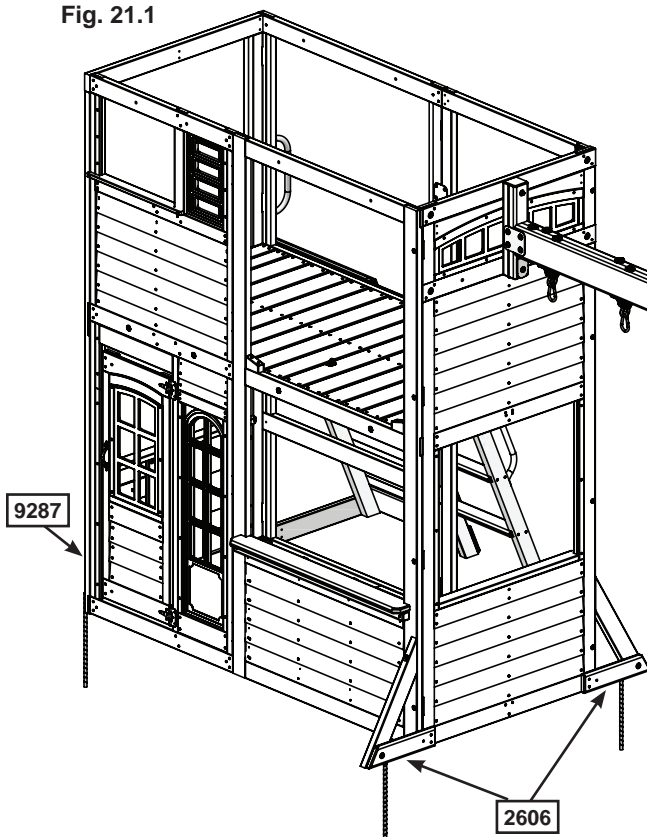
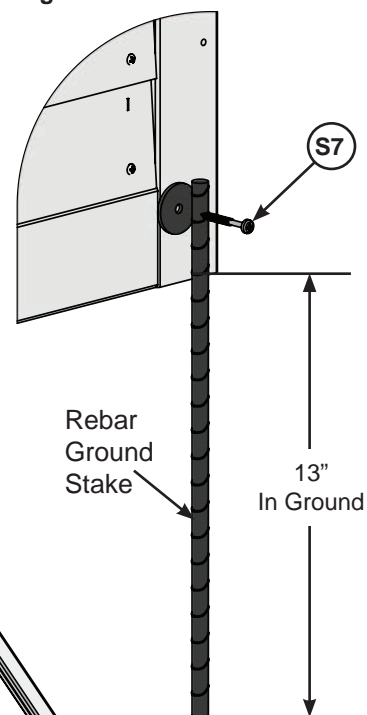

Fig. 21.2



**SEE FRONT COVER FOR
SAFETY CLEARANCE**

Hardware

5 x (S7) #12 x 2" Pan Screw

Other Parts

5 x Rebar Ground Stake

Step 22: Attach Cross Frame Part 1

Note hole orientation for this step.

A: Tight to the floor boards and tight in each corner of (9287) Back Panel Assembly end wall, attach 2 (9553) Supports to (9286) Front Panel Assembly and (9287) Back Panel Assembly with 5 (S3) #8 x 2-1/2" Wood Screws per support. (Fig. 22.1)

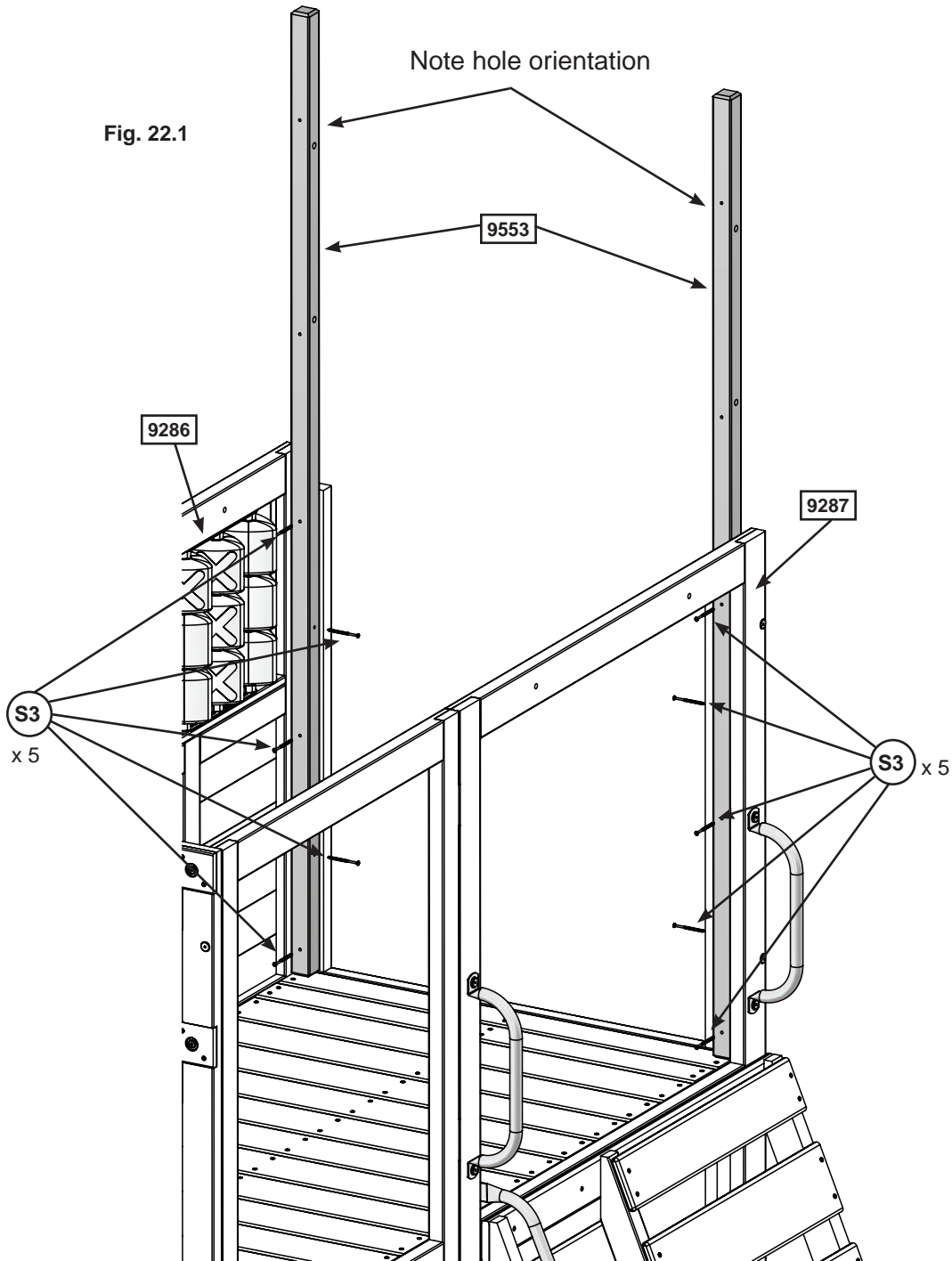

Wood Parts

2 x 9553 Support 1 1/2 x 1 1/2 x 72"

Hardware

10 x S3 #8 x 2-1/2" Wood Screw

Step 22: Attach Cross Frame Part 2

A: Place (9581) Cross Frame across the opening in the end panel as shown in fig. 22.2. Attach each end of the board to the (9553) Supports using 2 (S3) #8 x 2- 1/2" Wood Screws.

Fig. 22.2

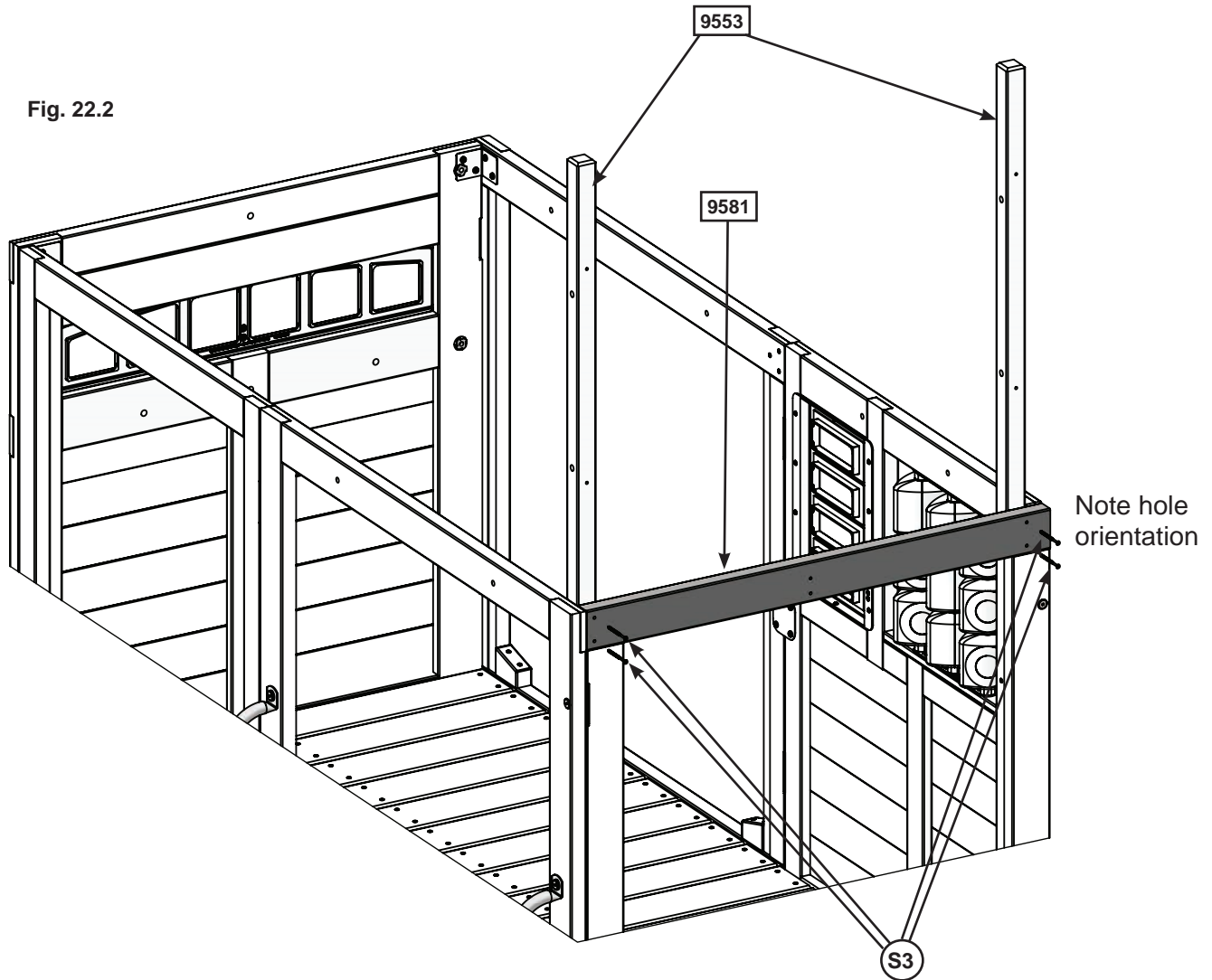

Wood Parts

1 x 9581 Cross Frame 1 1/4 x 3 x 37"

Hardware

4 x S3 #8 x 2-1/2" Wood Screw

Step 23: Attach Terrace Assembly Part 1

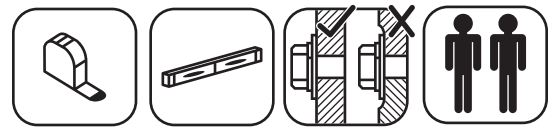

A: Place (9561) Terrace Support Right and (9560) Terrace Support Left on either side of (9562) Mid Joist, taking note of the hole orientation. Line (9562) Mid Joist up with the pre-drilled holes in each Terrace Support and attach using 2 (S3) #8 x 2 -1/2" Wood Screws per side. (Fig. 23.1)

B: From inside the assembly measure 5/8" (15.9mm) down from the top of the Wall Panels and place the Terrace Support Assembly so that the (9560) Terrace Support Left and (9561) Terrace Support Right are tight to the (9286 & 9287) Supports. (Fig. 23.2 & 23.3)

C: From inside, loosely install 2 (WB8) 5/16 x 2 -3/8" Wafer Bolts (with flat washer and t-nut) into (9560) Terrace Support Left and 3 (WB8) 5/16 x 2 -3/8" Wafer Bolts (with flat washer and t-nut) into (9561) Terrace Support Right. Check to make sure the Terrace Support Assembly is level, then tighten the Wafer Bolts. (Fig. 23.2 & 23.3)

D: Install 1 (S11) #8 x 2" Wood Screw into the end of (9560) Terrace Support Left as shown in fig. 23.2

Fig. 23.1

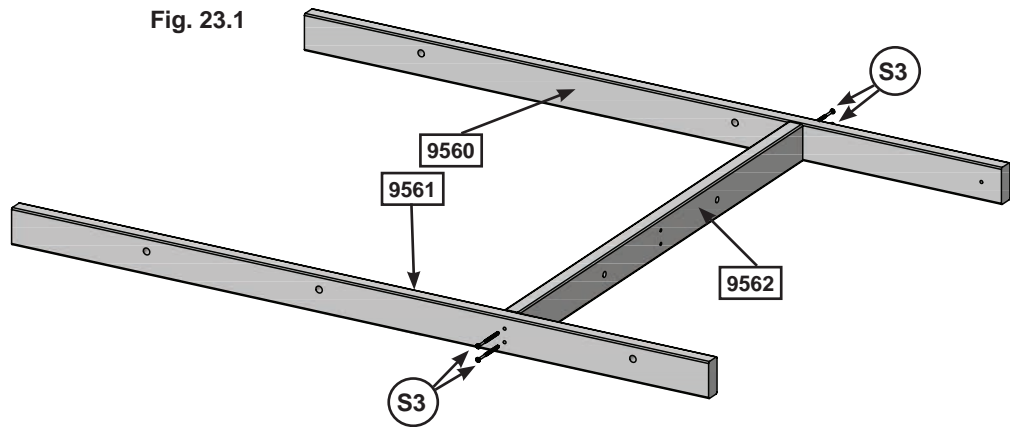

Fig. 23.2

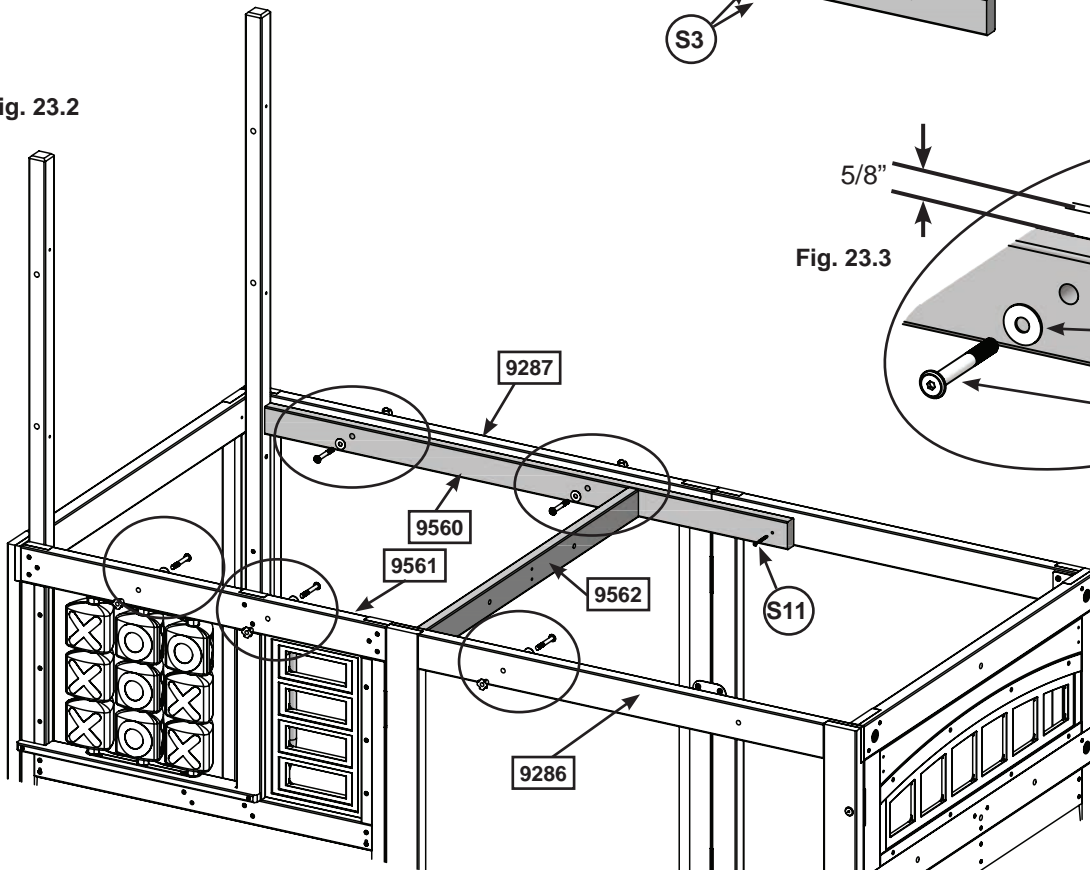
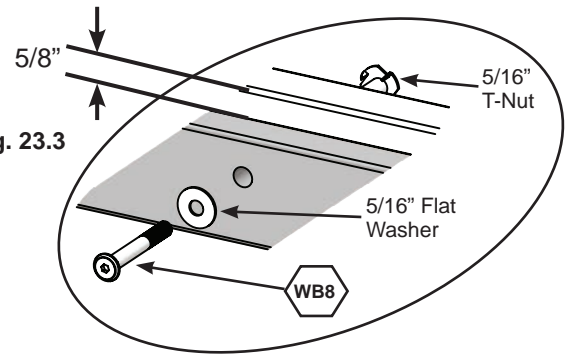

Fig. 23.3



Wood Parts

- 1 x Terrace support left 1 x 2 3/8 x 47 3/4"
- 1 x Terrace support Right 1 x 2 3/8 x 47 3/4"
- 1 x Mid Joist 1 x 2 3/8 x 33 11/16"

Hardware

- 5 x 5/16 x 2 -3/8" Wafer Bolt (5/16" flat washer, 5/16" t-nut)
- 4 x #8 x 2-1/2" Wood Screw
- 1 x #8 x 2" Wood Screw

Step 23: Attach Terrace Assembly Part 2



E: Place (9563) Deck Floor Support between (9562) Mid Joist and the end wall of (9287) Back Panel Assembly so that it is centered over the pilot holes as shown in fig. 23.4. Attach using 2 (S4) #8 x 3" Wood Screws per side.(Fig. 23.4 & 23.5). Make certain 9563 is 5/8" down from top of 9287 and 9562.

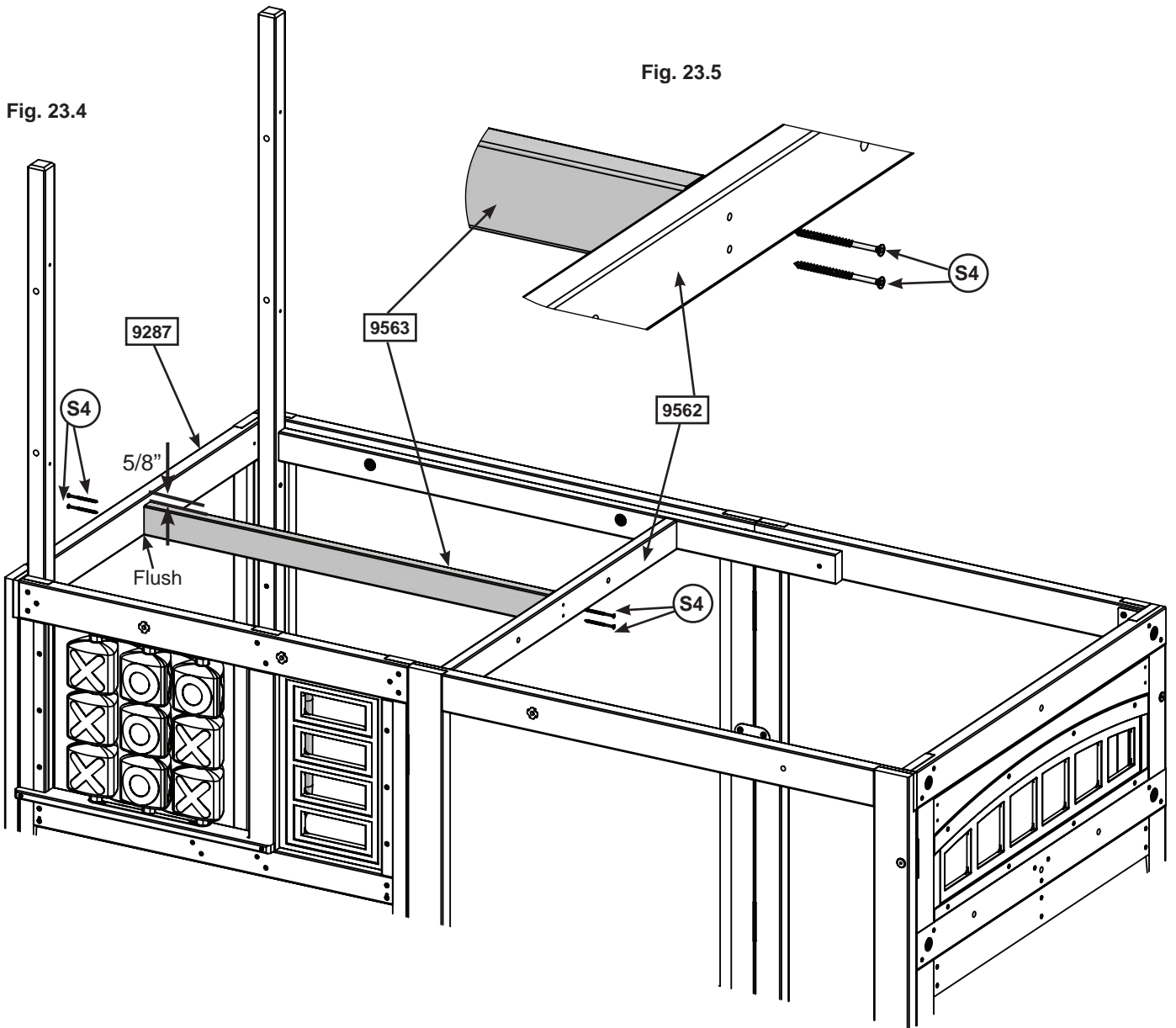

Wood Parts

1 x 9563 Deck floor support 1 x 2 3/8 x 34 11/16"

Hardware

4 x S4 #8 x 3" Wood Screw

Step 23: Attach Terrace Assembly Part 3

F: Place (9564) Terrace Floor Board so that it's tight to the (9553) Supports and attach using 6 (S20) #8 x 1- 3/8" Wood Screws. (Fig 23.6 & 23.7)

G: Place 1 (9051) Floor Board at the opposite end making sure that it's flush to the edge of (9562) Mid Joist and attach using 6 (S20) #8 x 1- 3/8" Wood Screws. (Fig 23.6 & 23.7)

H: Evenly space the remaining 6 (9051) Floor Boards and attach using 6 (S20) #8 x 1- 3/8" Wood Screws per board. (Fig 23.6 & 23.7)

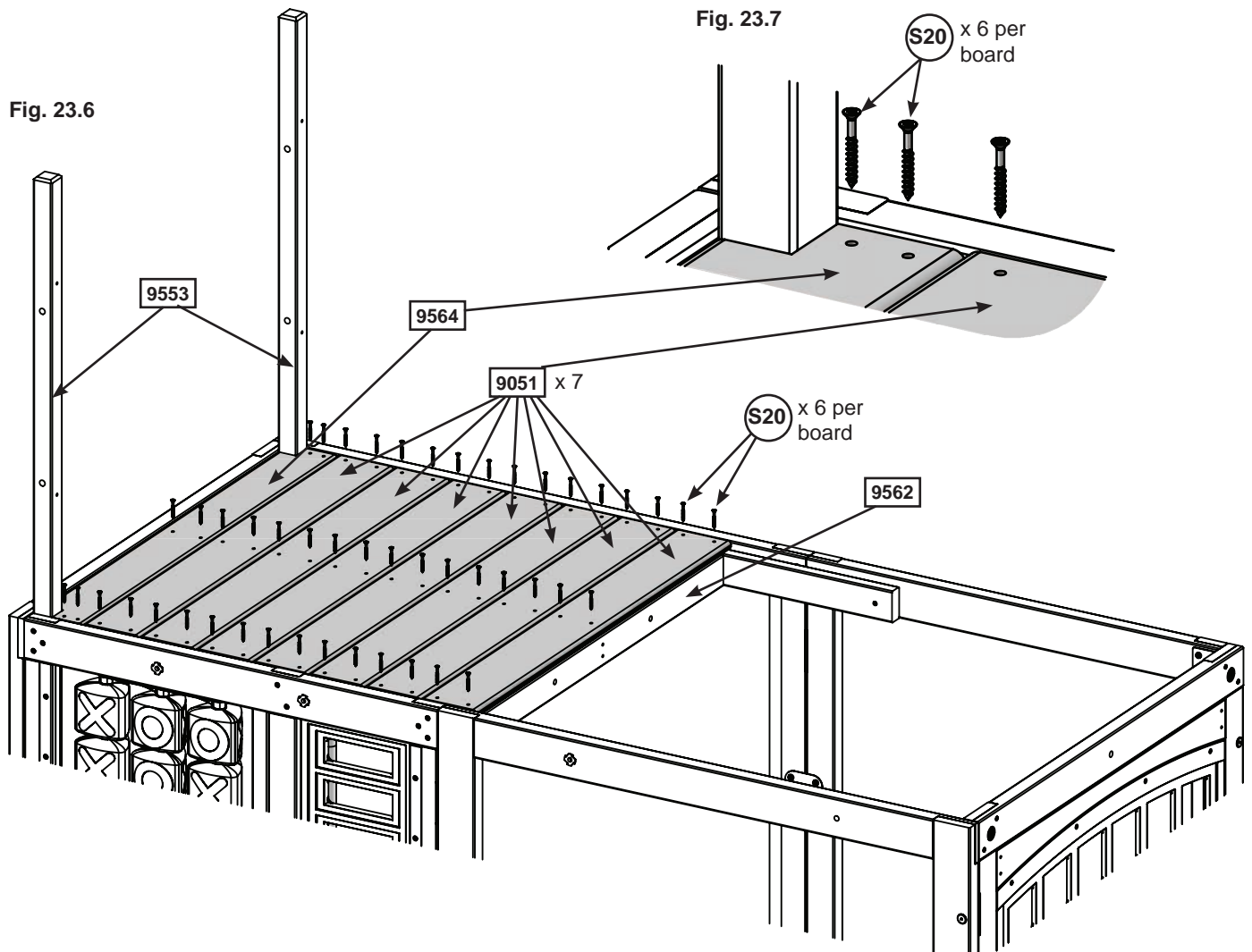

Wood Parts

- 1 x 9564 Terrace Floor Board 5/8 x 4 x 35 5/8"
- 7 x 9051 Floor Board 1 x 4 1/2 x 35 5/8"

Hardware

- 48 x S20 #8 x 1-3/8" Wood Screw

Step 24: Attach Fence Assembly Part 1

A: Place 2 (9558) Fence Bottom Narrows one above the other with the notched out ends facing up. Fit 1 (9556) Fence Post into the notches at each end of the (9558) Fence Bottom Narrows and attach using 2 (WB2) 5/16 x 1-3/8" Wafer Head Bolts (with flat washer, lock washer and t-nut) per board.

B: Flip the assembly over and install 5 (9566) Fence Boards into the pre-drilled holes using 2 (H2) 1/4 x 2" Hex Bolts (with flat washer, lock washer and t-nut) per board. (fig. 24.1)

Fig. 24.1

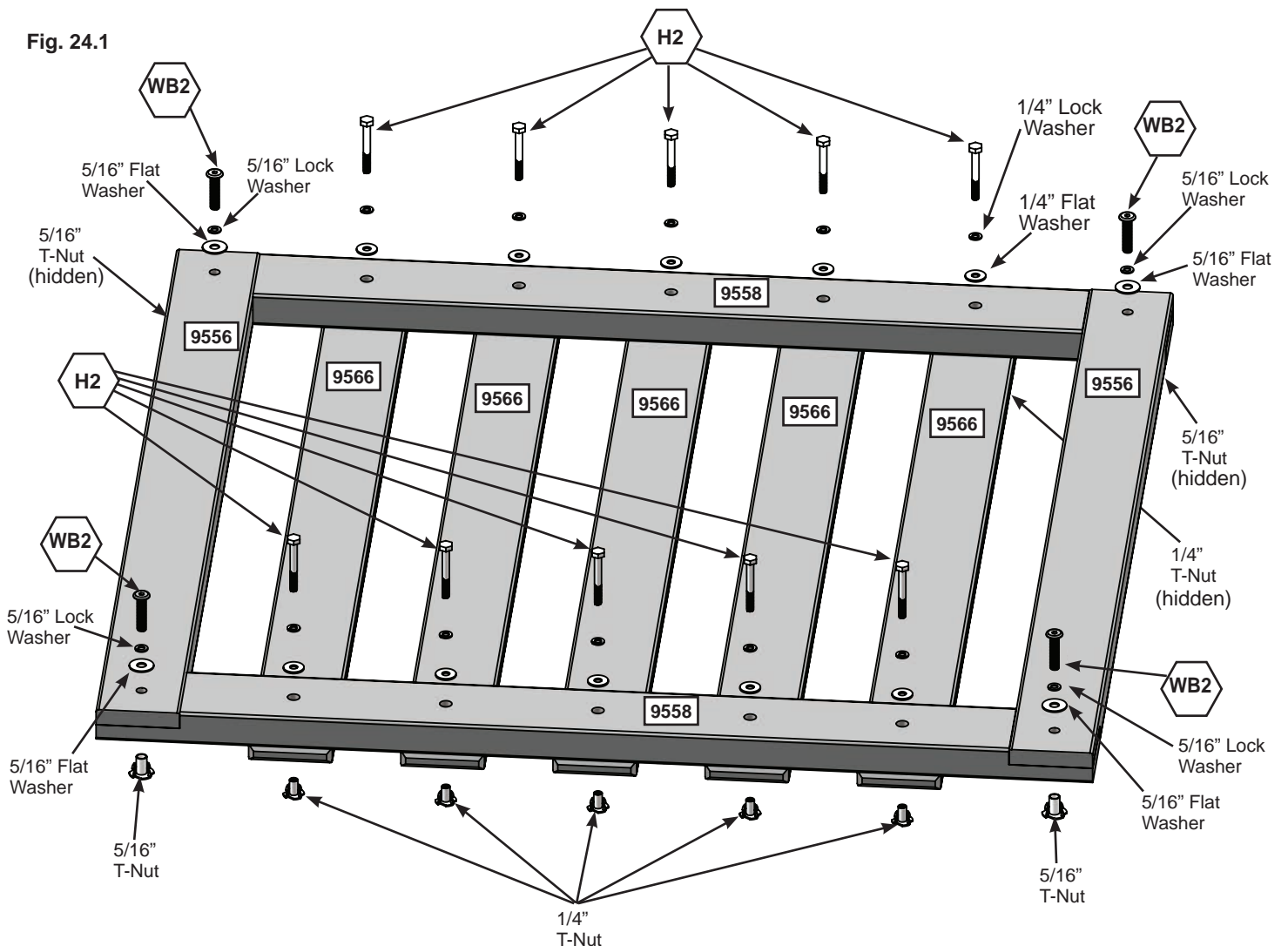

Wood Parts

- 2 x 9556 Fence Post 1 1/4 x 3 x 33"
- 2 x 9558 Fence Bottom Narrow 1 1/4 x 3 x 35 3/4"
- 5 x 9566 Fence Board 5/8 X 3 X 33"

Hardware

- 4 x WB2 5/16 x 1-3/8" Wafer Head Bolt (5/16" flat washer, 5/16" lock washer, 5/16" t-nut)
- 10 x H2 1/4 x 2" Hex Bolts (with flat washer, lock washer and t-nut)

Step 24: Attach Fence Assembly Part 2

C: Place 2 (9555) Bottom Fence boards one above the other with the notched out ends facing up. Fit 1 (9556) Fence Post into the notches on the right side of the (9558) Fence Bottom Narrows 1 (9557) Fence Post A on the left side and attach using 2 (WB2) 5/16 x 1- 3/8" Wafer Head Bolts (with flat washer, lock washer and t-nut) per board.

D: Flip the assembly over and install 5 (9566) Fence Boards into the pre-drilled holes using 2 (H2) 1/4 x 2" Hex Bolts (with flat washer, lock washer and t-nut) per board. (fig. 24.2)

Fig.24.2

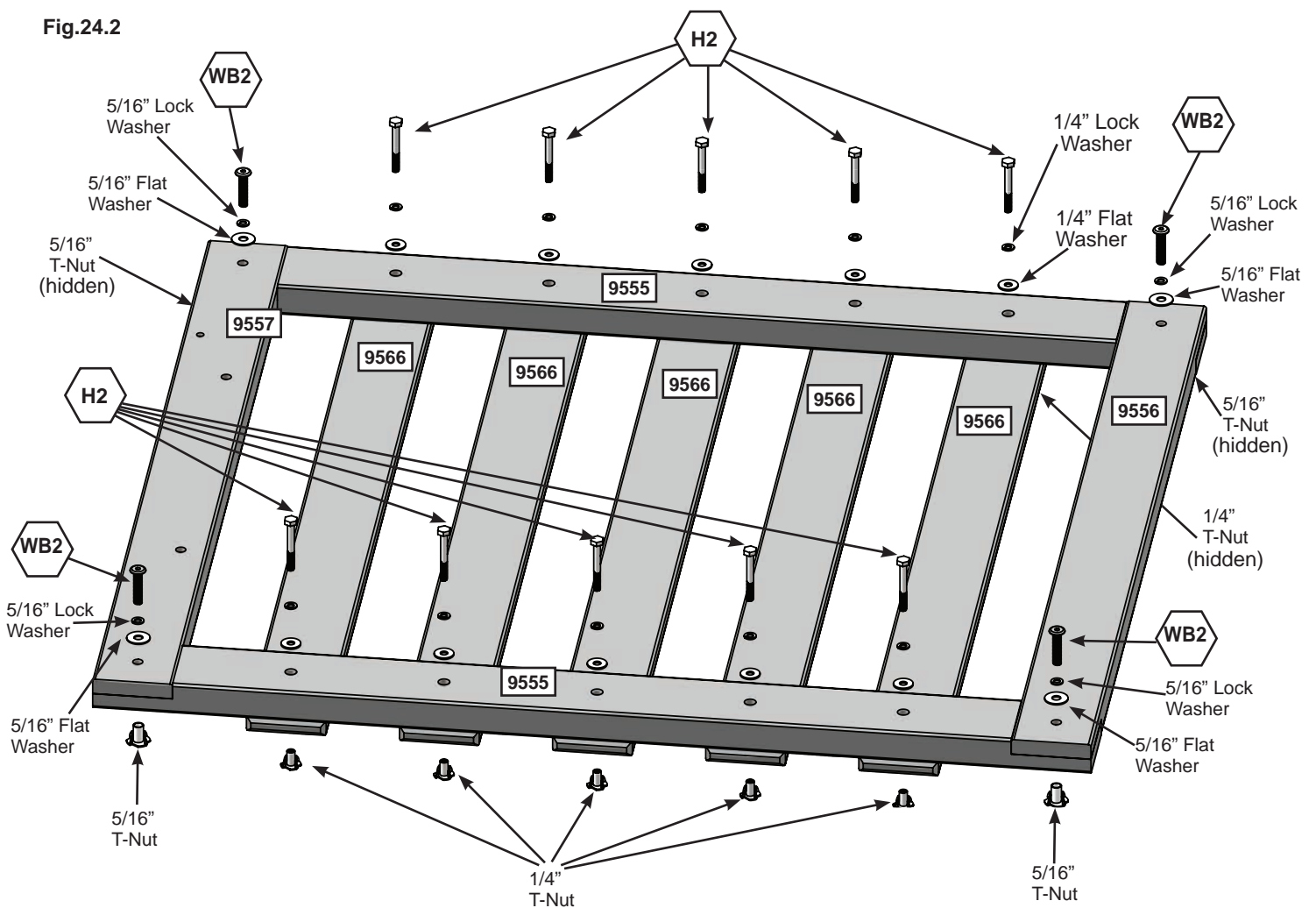

Wood Parts

- 1 x 9556 Fence Post 1 1/4 x 3 x 33"
- 2 x 9555 Bottom Fence 1 1/4 x 3 x 37 9/16"
- 5 x 9566 Fence Board 5/8 X 3 X 33"
- 1 x 9557 Fence Post A 1 1/4 x 3 x 33"

Hardware

- 4 x WB2 5/16 x 1-3/8" Wafer Head Bolt (5/16" flat washer, 5/16" lock washer, 5/16" t-nut)
- 10 x H2 1/4 x 2" Hex Bolts (with flat washer, lock washer and t-nut)

Step 24: Attach Fence Assembly Part 3

E: Place 2 (9555) Bottom Fence boards one above the other with the notched out ends facing up. Fit 1 (9557) Fence Post A into the notches on the right side of the (9558) Fence Bottom Narrows 1 (9556) Fence Post on the left side and attach using 2 (WB2) 5/16 x 1- 3/8" Wafer Head Bolts (with flat washer, lock washer and t-nut) per board.

F: Flip the assembly over and install 5 (9566) Fence Boards into the pre-drilled holes using 2 (H2) 1/4 x 2" Hex Bolts (with flat washer, lock washer and t-nut) per board. (fig. 24.3)

Fig. 24.3

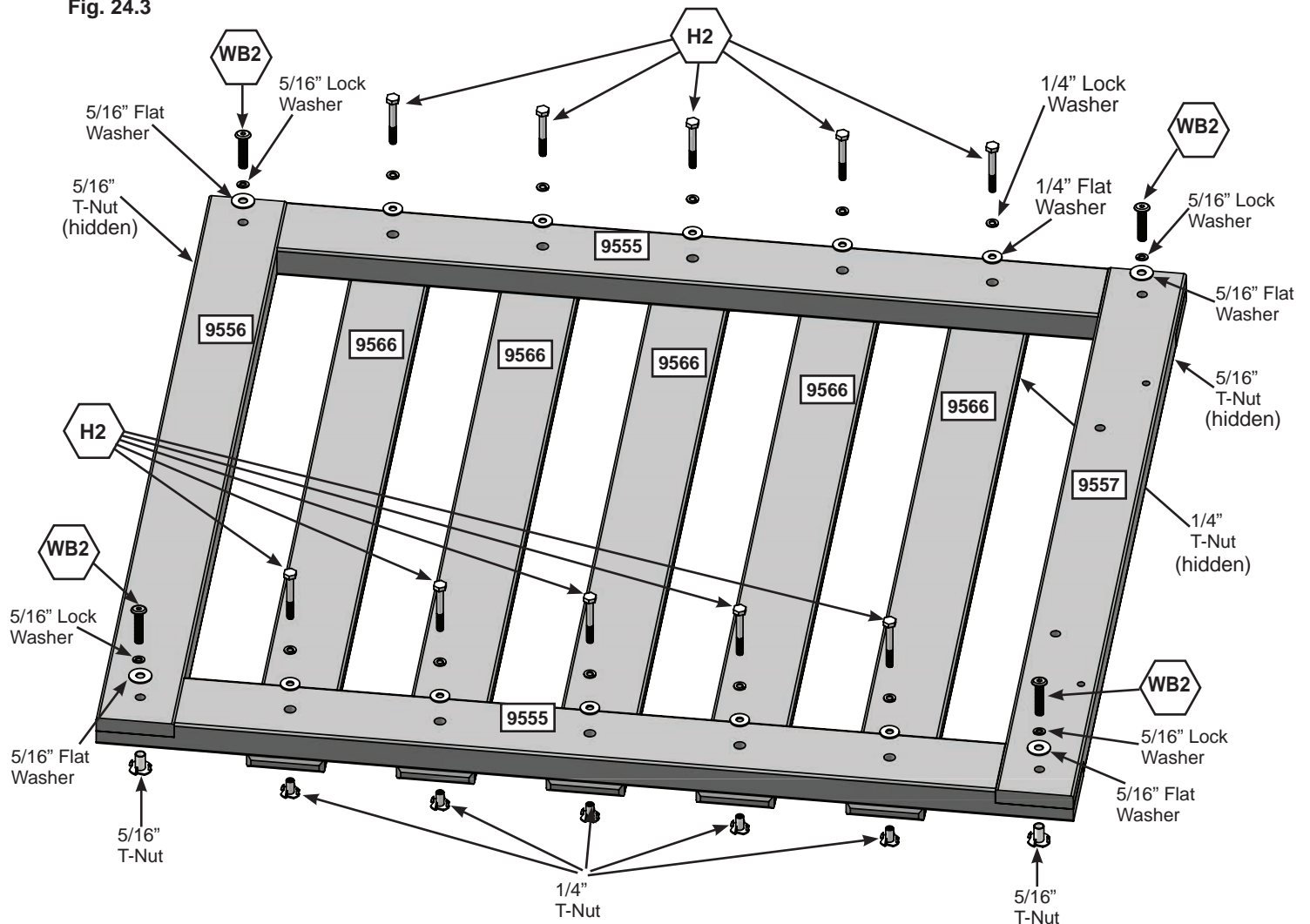

Wood Parts

- 1 x 9556 Fence Post 1 1/4 x 3 x 33"
- 2 x 9555 Bottom Fence 1 1/4 x 3 x 37 9/16"
- 5 x 9566 Fence Board 5/8 X 3 X 33"
- 1 x 9557 Fence Post A 1 1/4 x 3 x 33"

Hardware

- 4 x WB2 5/16 x 1-3/8" Wafer Head Bolt
(5/16" flat washer, 5/16" lock washer, 5/16" t-nut)
- 10 x H2 1/4 x 2" Hex Bolts (with flat washer, lock washer and t-nut)

Step 24: Attach Fence Assembly Part 4



G: Bring the fence panel assemblies together as shown in fig. 24.4, making sure that the panel configuration is correct and that the panels are flush at the bottom corners. Check to make sure that the assembly is square and pre-drill using a 3/16" drill bit, then attach the panels together using 2 (WL5) 1/4 x 2- 1/2" Wafer Lags (with 5/16 flat washer) per side. (fig. 24.4)

Fig. 24.4

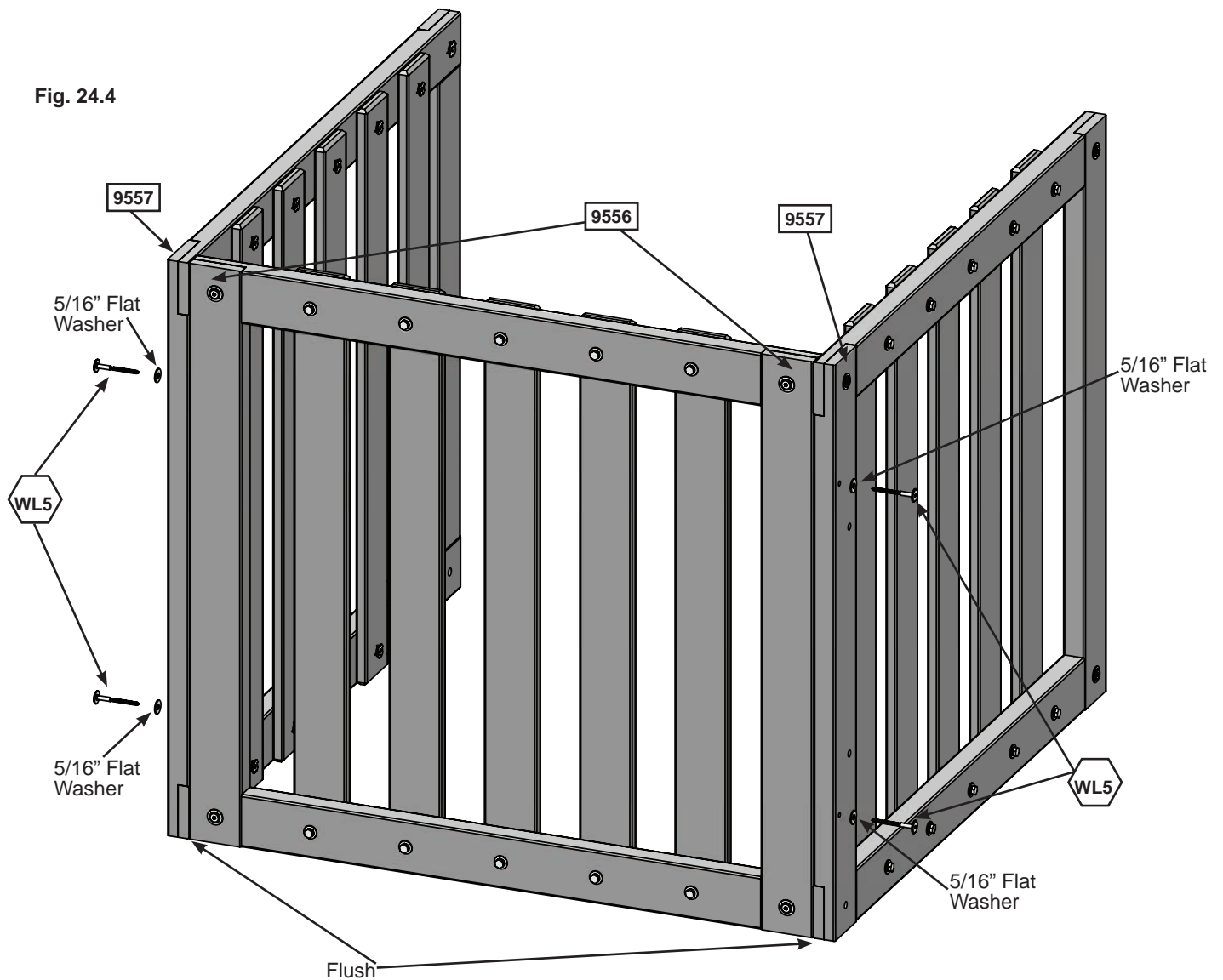

Hardware

4 x  1/4 x 2-1/2" Wafer Lag (5/16" flat washer)

Step 25: Attach Fence to Fort



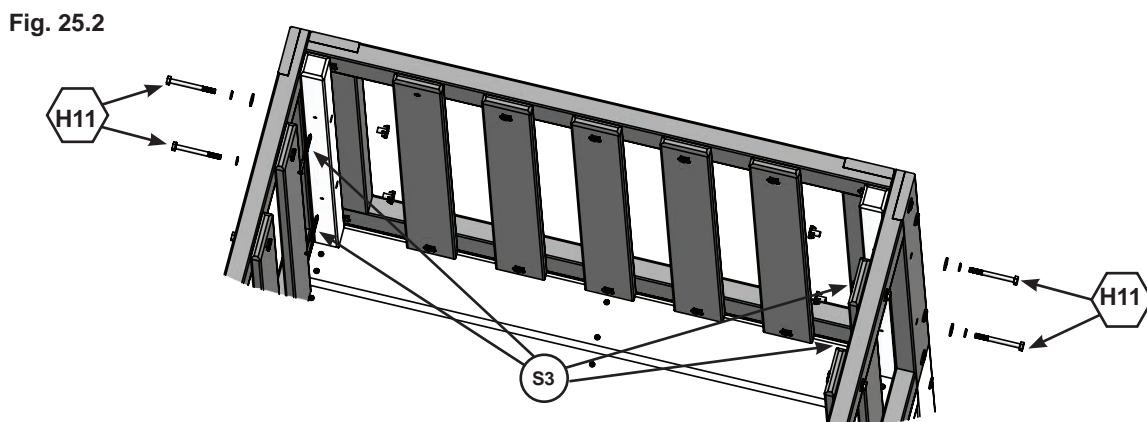
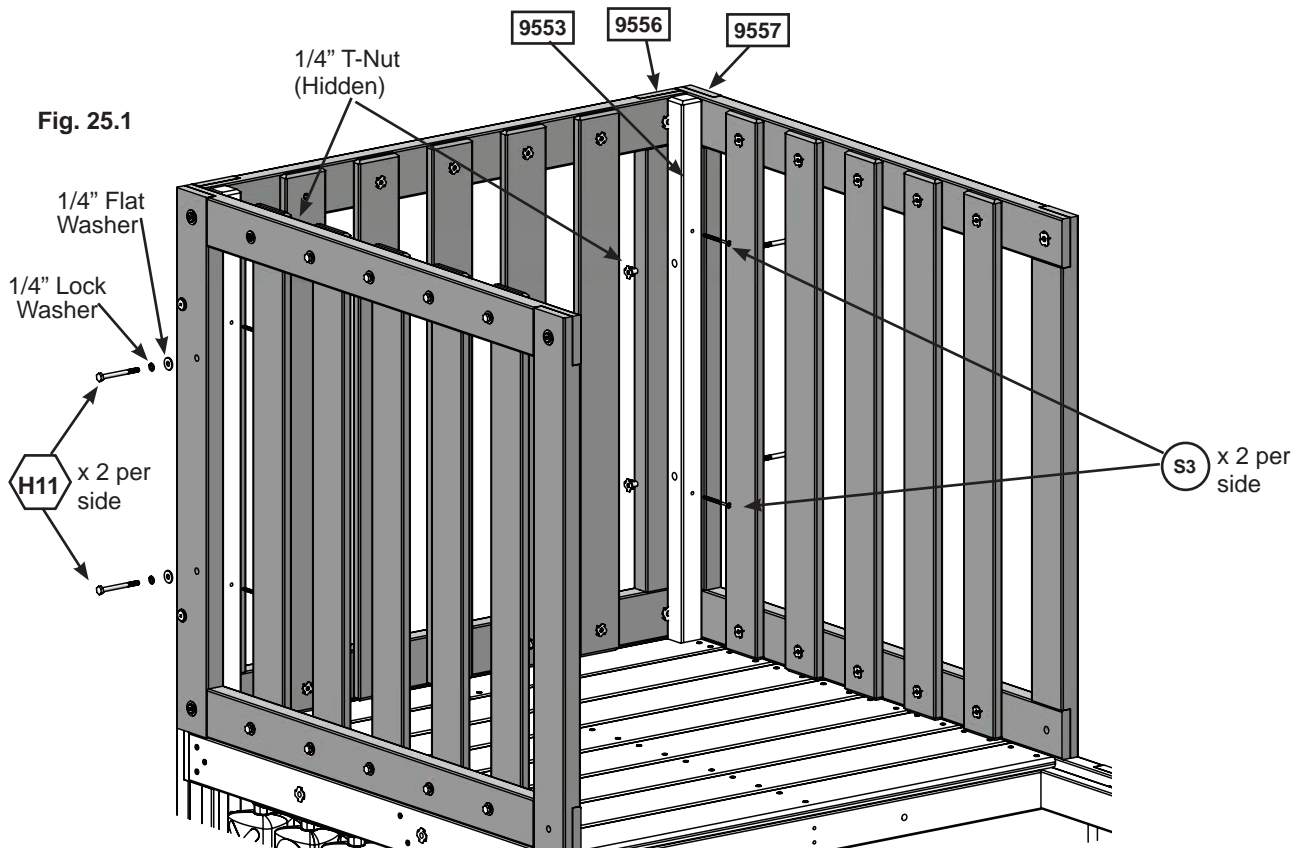

A: With a helper, lift the fence assembly onto the open end of the fort so that the (9553) Supports are positioned on the inside corners of the fence assembly. Attach fence assembly to the (9553) Supports from the outside using 2 (H11) 1/4" x 2- 3/4" Hex Bolts (with lock washer, flat washer and-nut) per side. (fig. 25.1 and 25.2)

B: Install 2 (S3) #8 x 2- 1/2" Wood Screws into each (9553) Support as shown in fig. 25.1.



Hardware

- 4 x  #8 x 2-1/2" Wood Screw
- 4 x  1/4 x 2-3/4" Hex Bolt
(1/4" lock washer, 1/4" flat washer, 1/4" t-nut)

Step 26: Nest Ladder Assembly Part 1



A: Place (9570) Nest Left Access on one side of 3 (9571) Nest Treads and (9569) Nest Right Access on the other side with the grooves facing in. (fig. 26.1 & 26.2)

B: Fit each (9571) Nest Tread into grooves on both (9569) and (9570) Nest Access Rails, making sure the top edge of the (9571) Nest Treads are flush to the front of the Access rails. (fig. 26.1 & 26.2)

C: Pre-drill pilot holes with a 1/8" drill bit and attach rails and treads together using 4 (S3) #8 x 2-1/2" Wood Screws per tread. (fig. 26.1 & 26.2)

D: Place (9572) Stop Behind on each access rail so there is a 2-3/8" gap between (9572) Stop Behind and the top (9571) Nest Tread. Attach using 4 (S11) #8 x 2" Wood Screws. (fig. 26.3)

Fig. 26.1

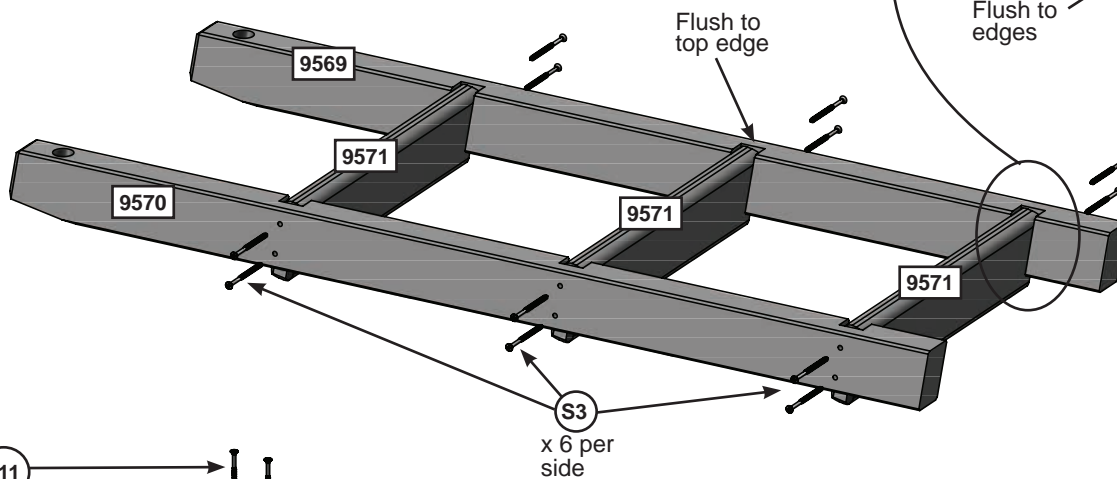

Fig. 26.2
End View

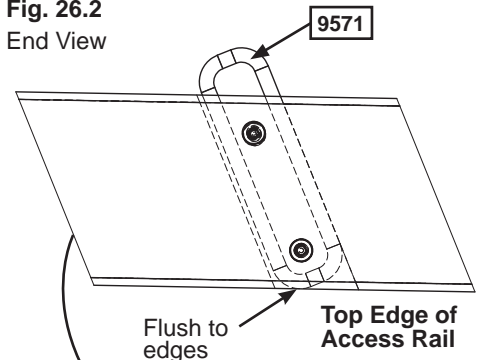
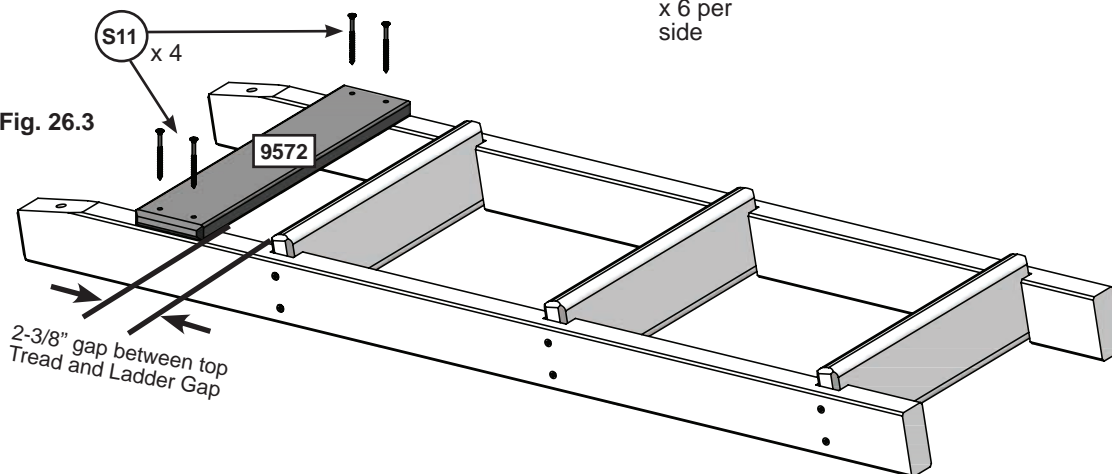

Fig. 26.3



Wood Parts

- 1 x **9569** Nest Right Access 1 3/8 x 2 1/2 x 39 13/16"
- 1 x **9570** Nest Left Access 1 3/8 x 2 1/2 x 39 13/16"
- 3 x **9571** Nest Tread 15/16 x 3 1/4 x 13 1/2"
- 1 x **9572** Stop 5/8 x 3 x 14 3/4"

Hardware

- 12 x **S3** #8 x 2-1/2" Wood Screw
- 4 x **S11** #8 x 2" Wood Screw

Step 26: Nest Ladder Assembly Part 2



E: Place Nest Ladder in the second level of the Clubhouse so that it's centered and the top of the ladder is leaning flat against the (9562) Mid Joist. (Fig. 26.4)

F: Check to ensure that the Nest Ladder is flush to the top of the Floor Boards then pre-drill using a 1/8" drill bit. Attach Nest Ladder using 1 (WB8) 5/16 x 2-3/8" Wafer Bolt (with flat washer, T-nut) per side. (Fig. 26.4)

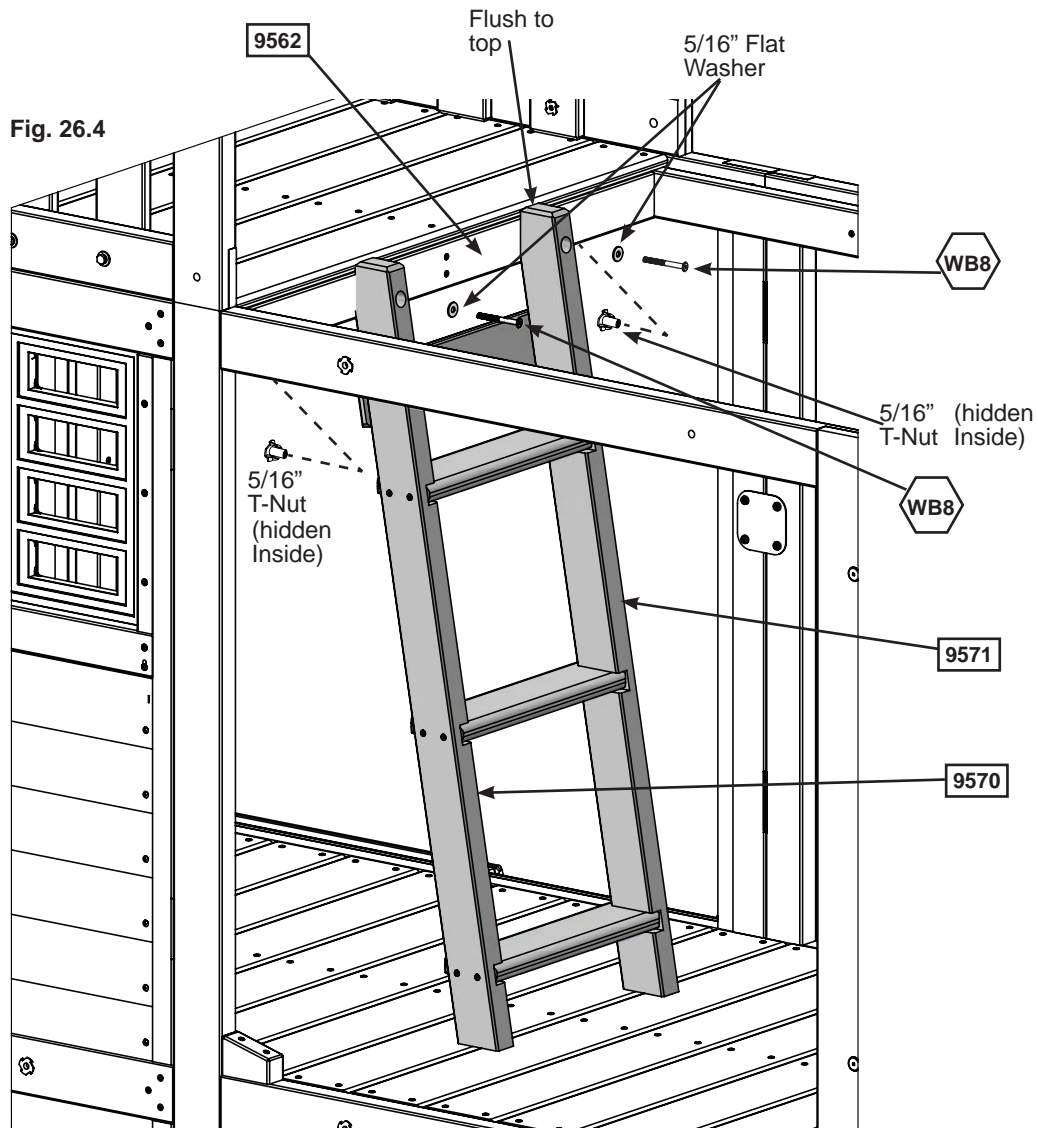

Hardware

2 x  5/16 x 2-3/8" Wafer Bolt (5/16" flat washer, 5/16" T-Nut)

Step 26: Nest Ladder Assembly Part 3

G: Place 1 Corner Bracket on the bottom outside edge of (9570) Nest Left Access so that it's flush to the front of the ladder and the straight edge of the bracket is on the floor board. Attach using 3 (S37) #7 x 5/8" Pan Screw.(fig. 26.5 &26.6)

Fig. 26.5

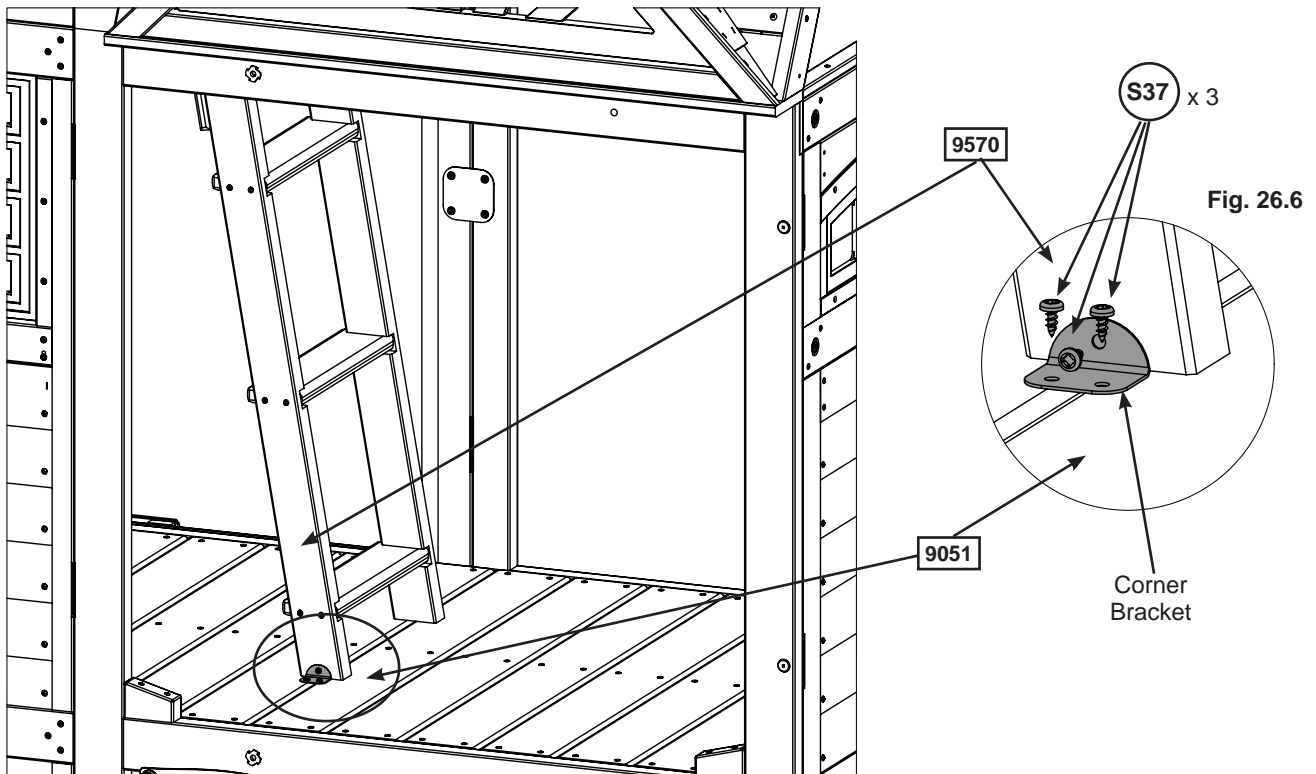

Hardware

3 x  #7 x 5/8" Pan Screw

Other Parts

1 x Corner Bracket

Step 27: Roof Assembly Part 1

A: Making sure that the sharper angles are at the top, place (9551) Roof Support Left and (9552) Roof Support Right together so they form a peak. Attach using 1 (S3) #8 x 2- 1/2" Wood Screw. (fig. 27.1)

B: Repeat Step A to create a second Roof Support Assembly. (fig. 27.1)

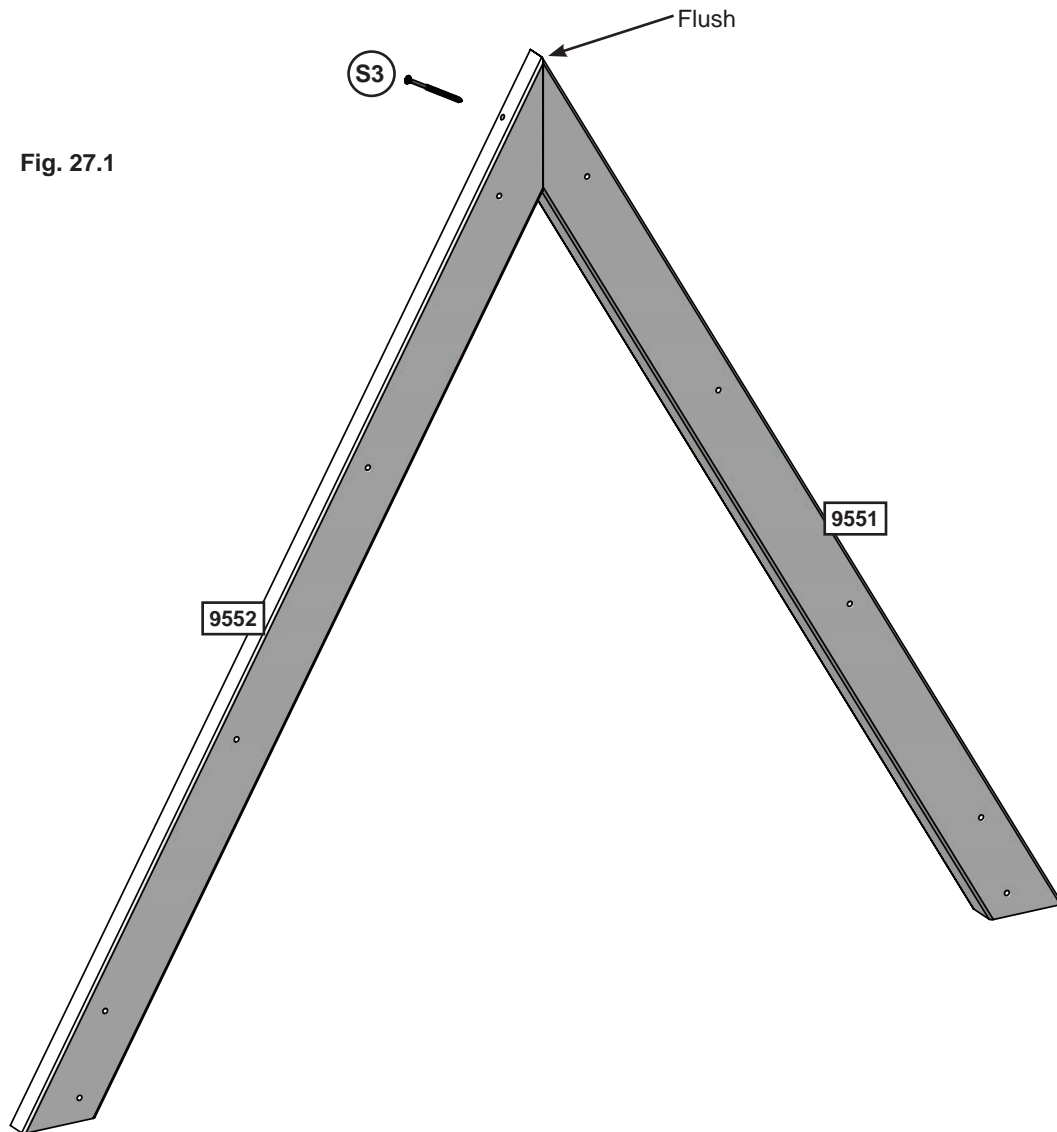

Wood Parts

- 2 x Roof support Left 1 1/4 x 3 x 42 1/4"
- 2 x Roof support Right 1 1/4 x 3 x 42 1/4"

Hardware

- 2 x #8 x 2-1/2" Wood Screw

Step 27: Roof Assembly Part 2



C: With a helper, hold (9276) Back Roof and (9277) Front Roof in position so that they are flush at the roof peak and line up with the roof support assemblies.

D: Making sure that the roof support assemblies are flush to the bottom of the roof panels, attach each roof support assembly to each end of the roof panels using 8 (S11) #8 x 2" Wood Screws per end. (fig. 27.2)

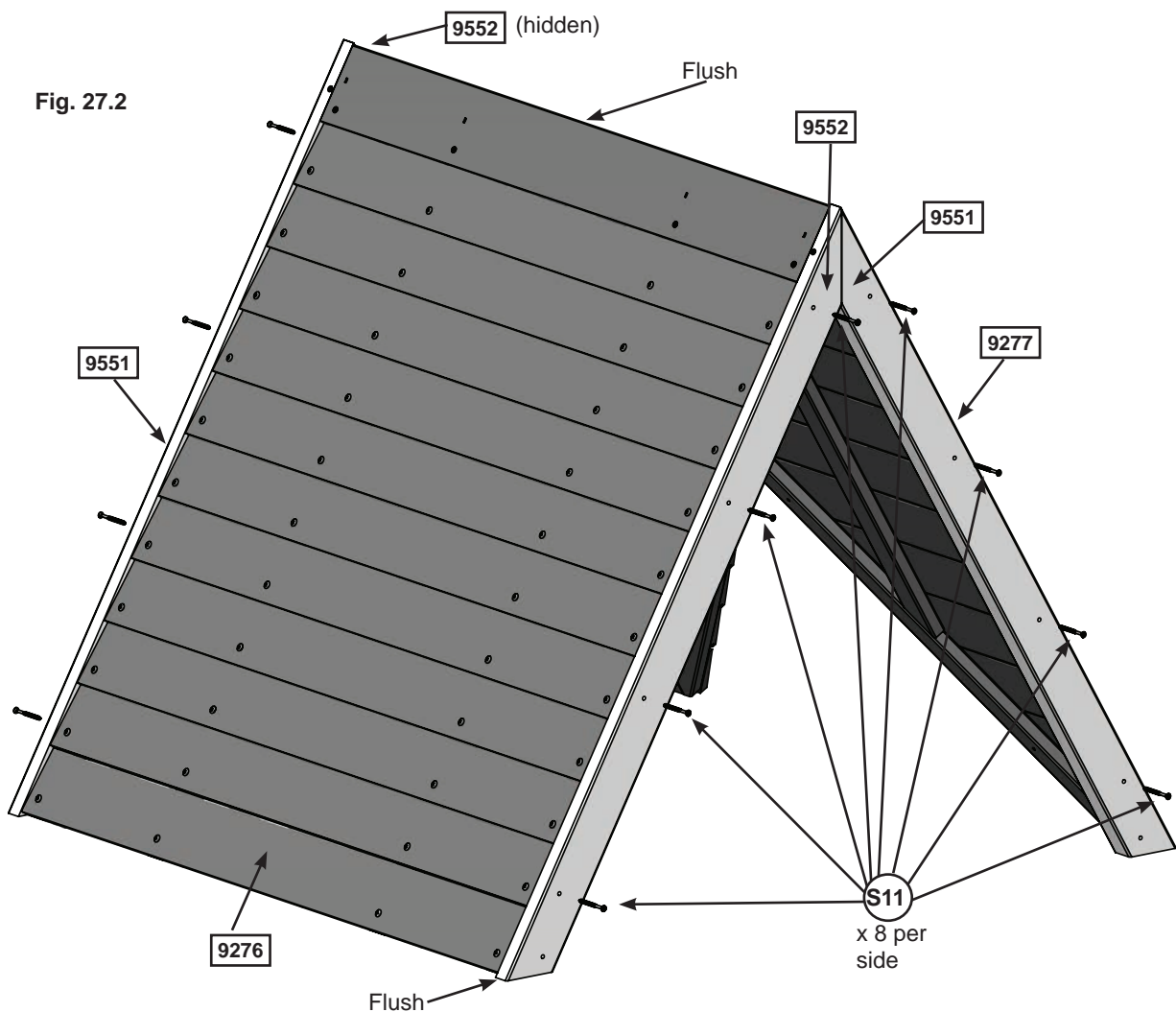

Wood Parts

- 1 x 9276 Back Roof 1 1/4 x 38 1/4 x 40 13/16"
- 1 x 9277 Front Roof 1 1/4 X 38 1/4 X 40 13/16"

Hardware

- 16 x S11 #8 x 2" Wood Screw

Step 27: Roof Assembly Part 3

E: Secure (9277) Front Roof to (9276) Back Roof at the top of the assembly using 4 (S11) #8 x 2" Wood Screws.
(fig. 27.3)

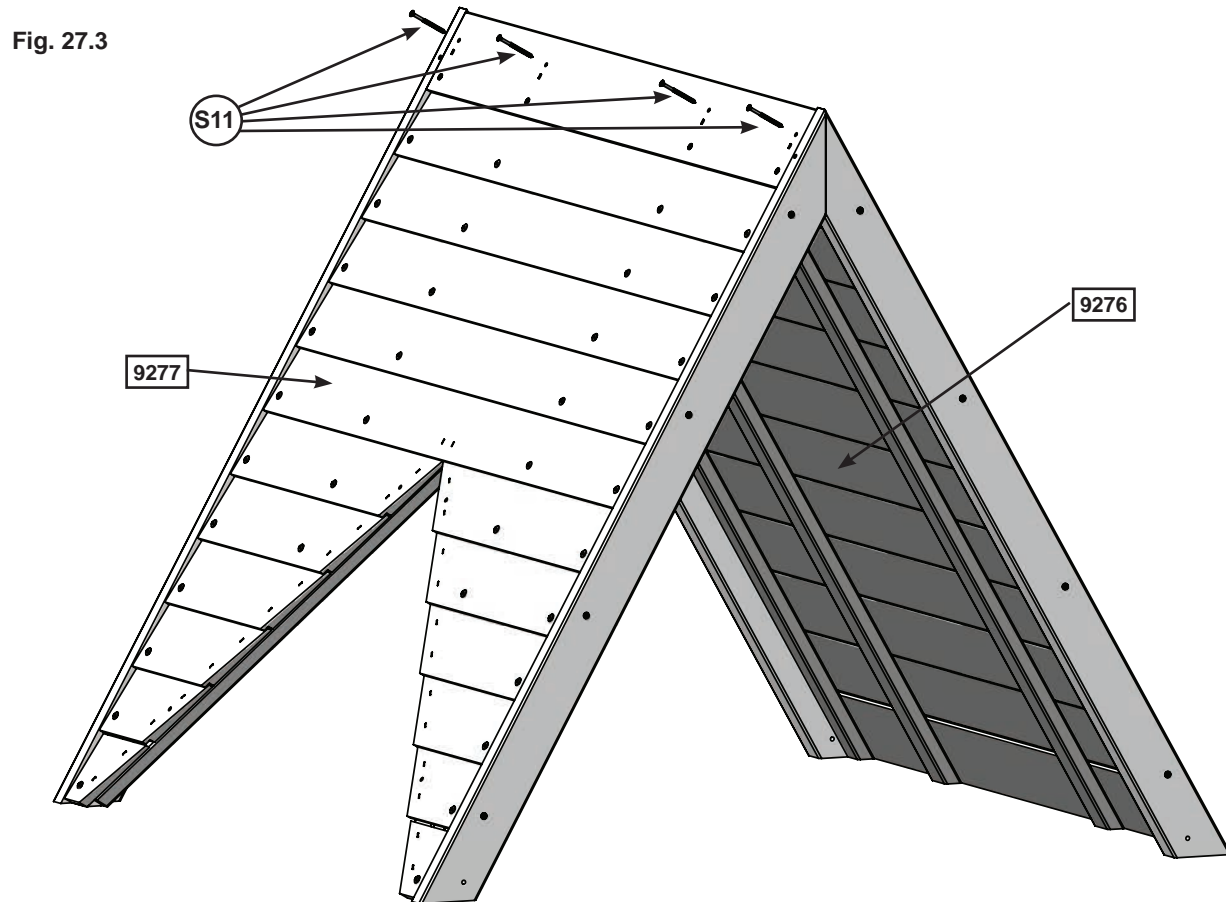

Hardware

4 x (S11) #8 x 2" Wood Screw

Step 27: Roof Assembly Part 4

F: From inside the roof assembly, place 1 Small Triangle Window into the top right corner and attach using 6 (S0) #8 x 7/8" Truss Screws. (fig. 27.4 & 27.5)

Fig. 27.4

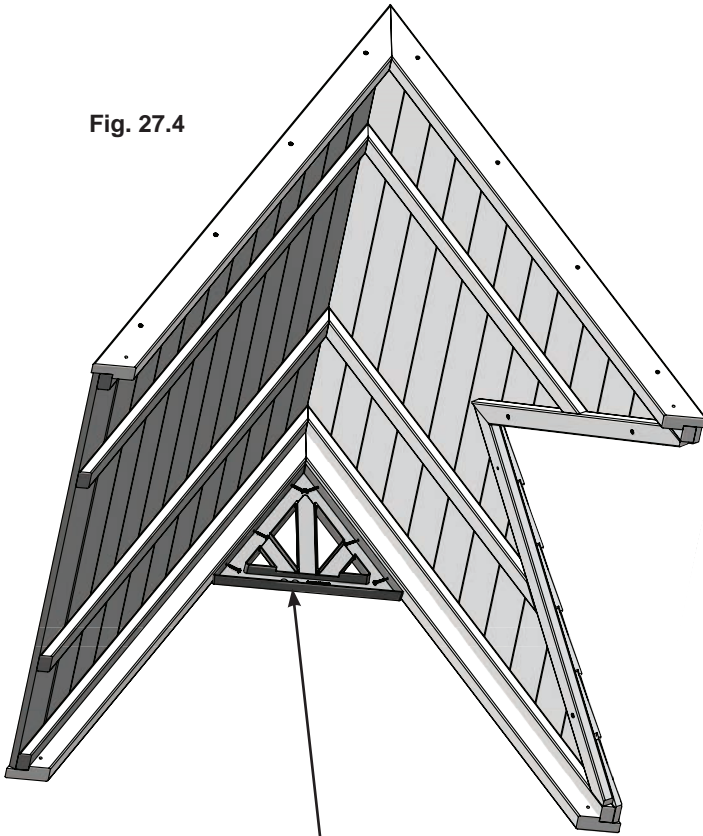

Small
Triangle
Window

Fig. 27.5

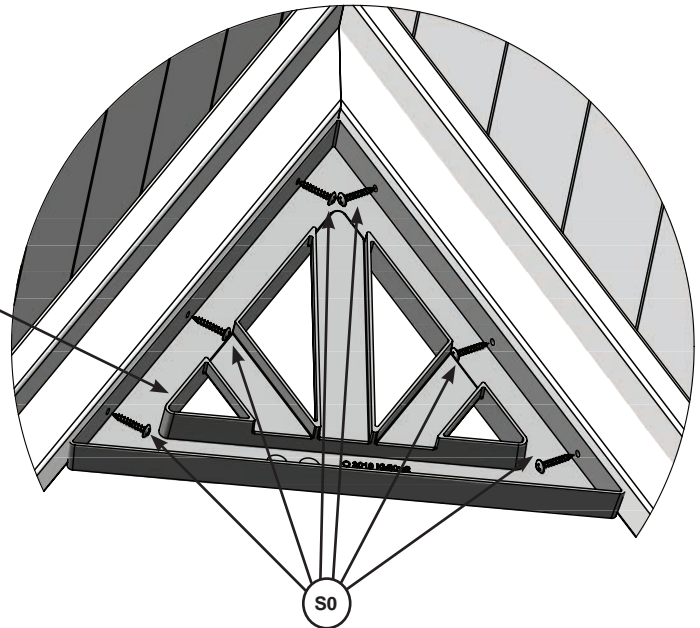

S0

Hardware

6 x  #8 x 7/8" Truss Screw

Other Parts

1 x Small Triangle Window

Step 28: Big Triangle Window Assembly Part 1



A: Place (9278) Housetop Skylight Left and (9279) Housetop Skylight Right together so they form a peak. Fit (9565) Skylight Bottom in place under the panels so that it's flush to the corners.

B: Attach (9565) Skylight Bottom to each skylight panel using 1 (S11) #8 x 2" Wood Screw per side. (fig. 28.1 & 28.2)

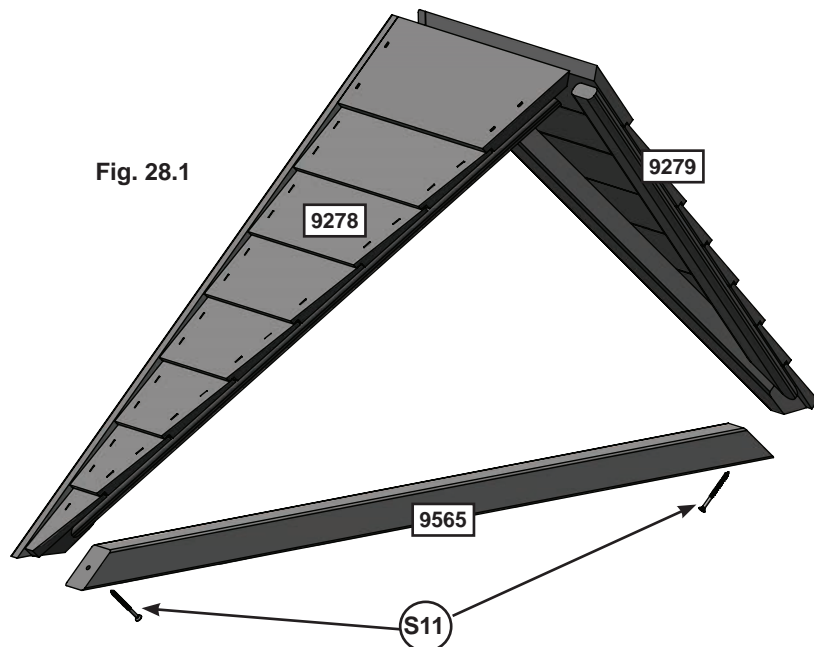

Fig. 28.1

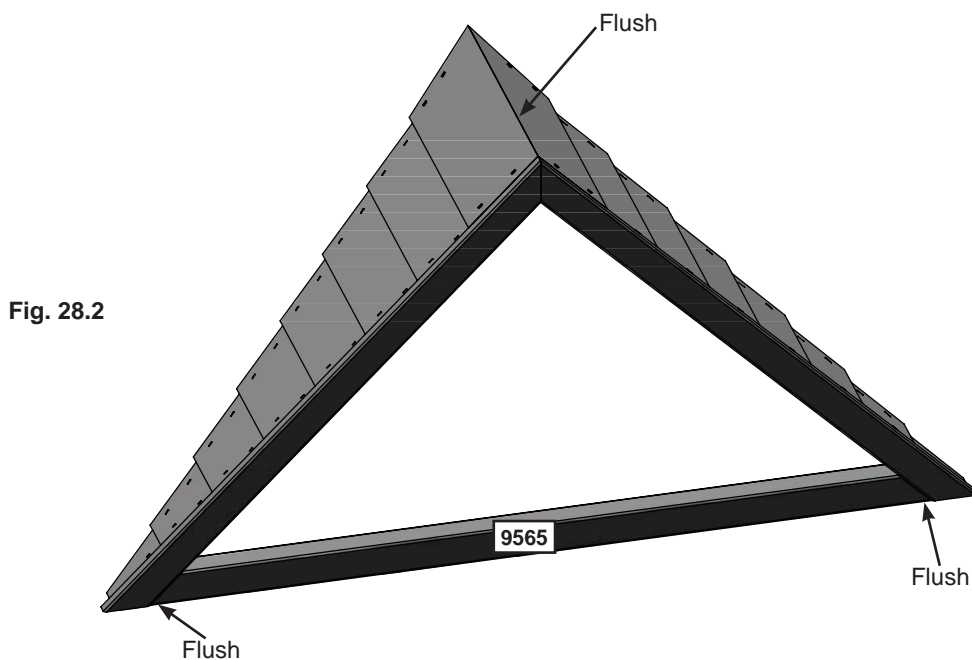

Fig. 28.2

Wood Parts

- 1 x 9278 Housetop skylight Left 1 1/8 x 12 7/16 x 28 5/16"
- 1 x 9279 Housetop skylight Right 1 1/8 x 12 7/16 x 28 5/16"
- 1 x 9565 Skylight Bottom 1 1/4 x 1 1/4 x 35 1/16"

Hardware

- 2 x S11 #8 x 2" Wood Screw

Step 28: Big Triangle Window Assembly Part 2

C: From the underside of the skylight assembly, place 1 New Big Triangle Window into the frame. Make sure (9278) Housetop Skylight Left and (9279) Housetop Skylight Right are tight together, then attach New Big Triangle Window using 9 (S0) #8 x 7/8" Truss Screws. (fig. 28.3 and 28.4)

D: Center 1 Narrow Angle Bracket over the slats and attach using 2 (S0) #8 x 7/8" Truss Screws. (fig. 28.5)

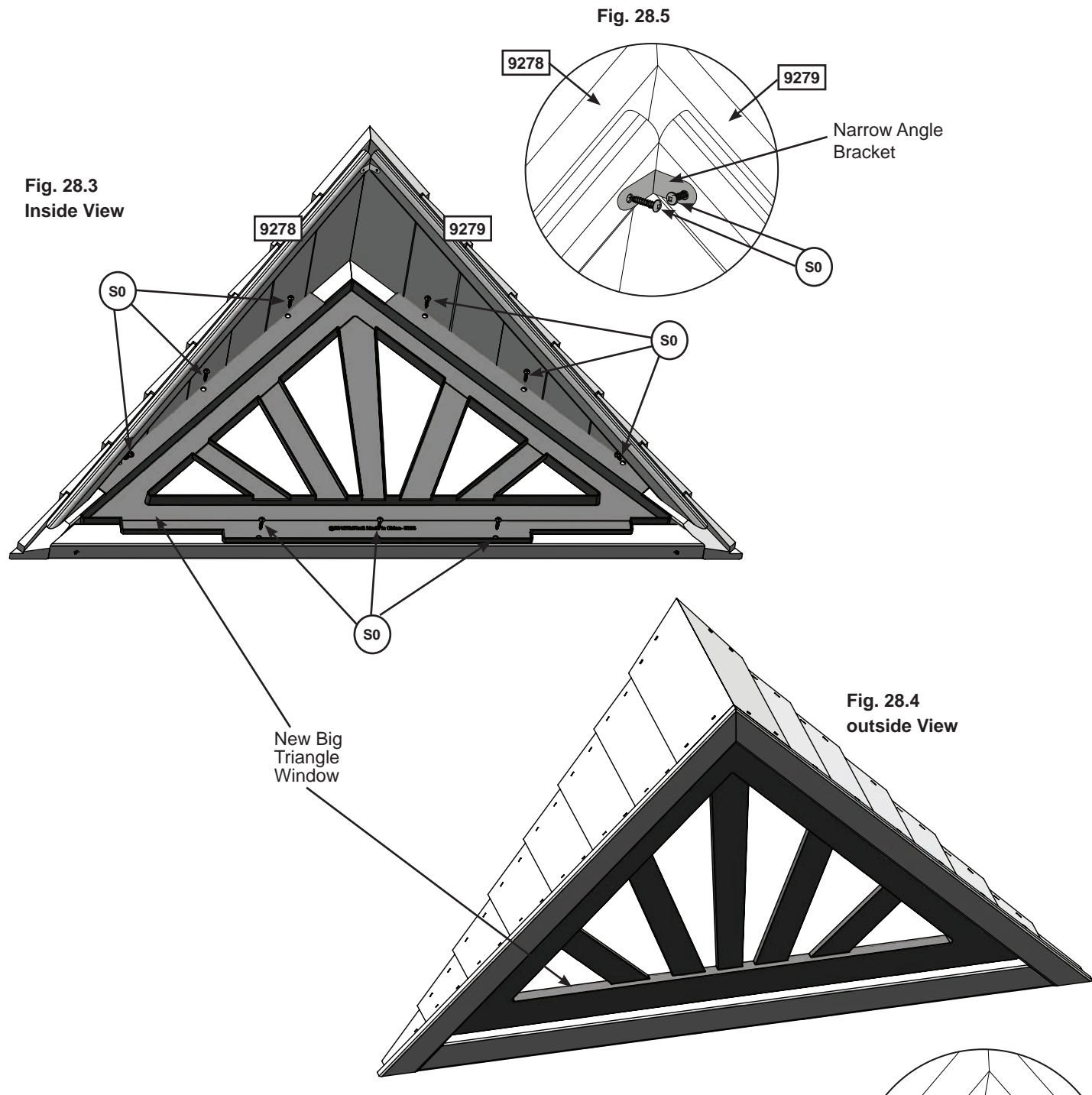

Hardware

11 x (S0) #8 x 7/8" Truss Screw

Other Parts

1 x New Big Triangle Window
1 x Narrow Angle Bracket

Step 28: Big Triangle Window Assembly Part 3

E: Attach (9278) Housetop Skylight Left to (9279) Housetop Skylight Right at the top corner using 1 (S11) #8 x 2" Wood Screw. (fig. 28.6)

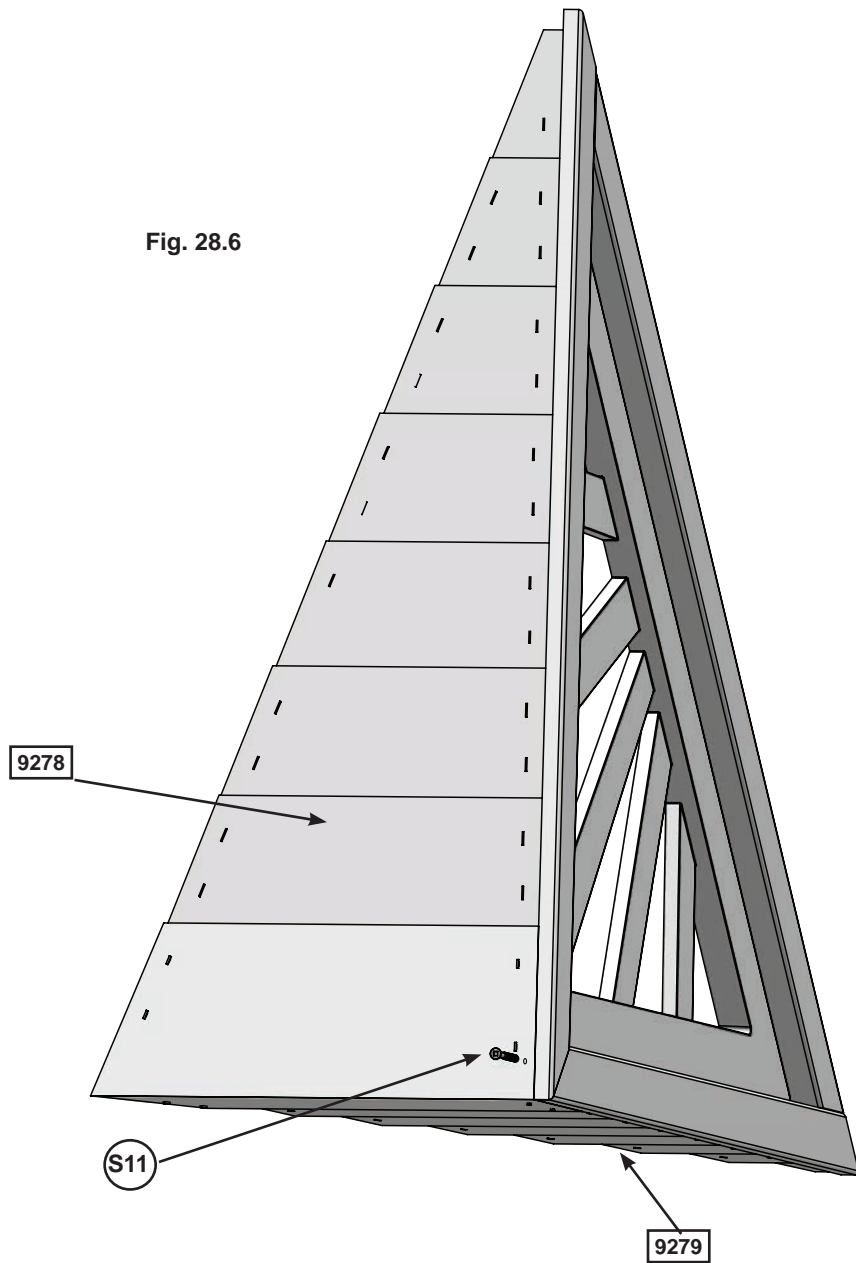

Hardware

1 x (S11) #8 x 2" Wood Screw

Step 29: Attach Big Triangle Window to Roof Assembly



A: With a helper, fit the Small Triangle Window Assembly into the opening of the Roof Assembly as shown in figs 29.1 and 29.2. Attach from the inside using 4 (S3) #8 x 2- 1/2" Wood Screws.

Fig. 29.1
Inside View

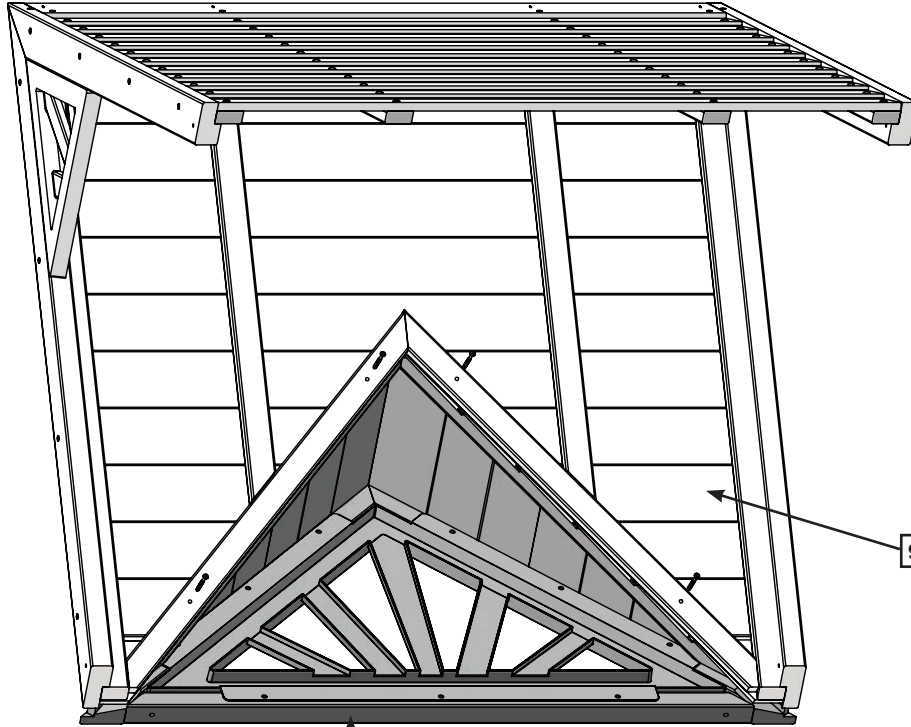

9277

Fig. 29.2
Side View

Big
Triangle
Window
Assembly

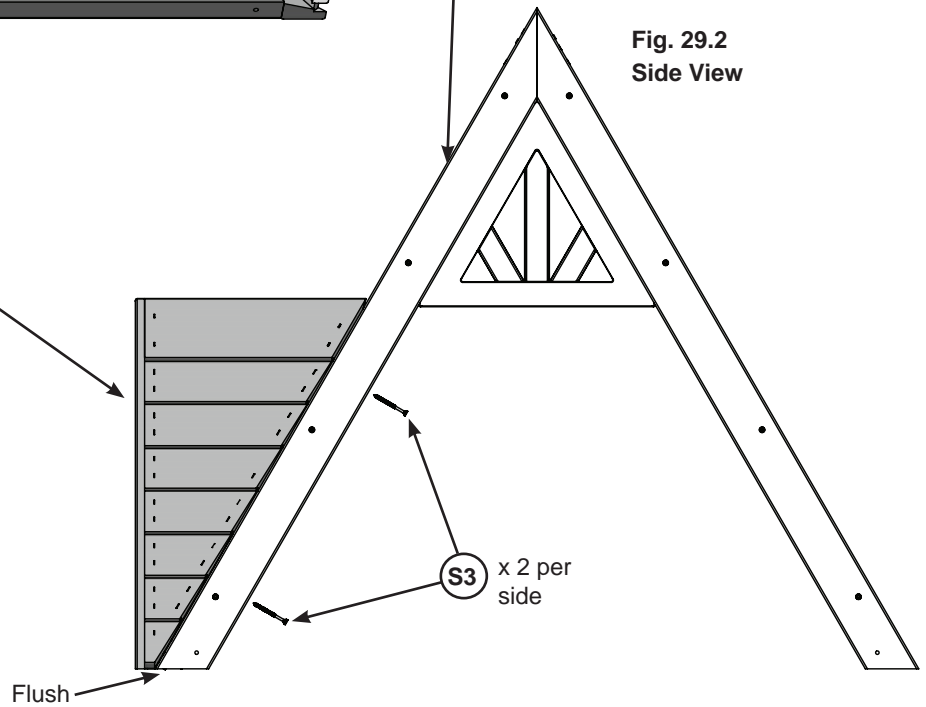

S3 x 2 per
side

Flush

Hardware

4 x S3 #8 x 2-1/2" Wood Screw

Step 30: Attach Soffits

A: Taking care to note the hole orientation, place 1 (9549) Roof Base along the top of the front wall panel so that it's flush with the inside of the wall. Attach using 4 (S20) #8 x 1- 3/8" Wood Screws. (fig. 30.1)

B: Place (9550) Narrow Roof Base along the end panel making sure that it's flush to (9549) Roof Base. Attach using 3 (S20) #8 x 1- 3/8" Wood Screws. (fig. 30.1)

C: Place (9554) Roof Base Narrow over the back wall panel so that it's flush to the inside edge of the wall and to (9550) Narrow Roof Base. Attach with 4 (S20) #8 x 1- 3/8" Wood Screws. (fig. 30.1)

Fig. 30.1

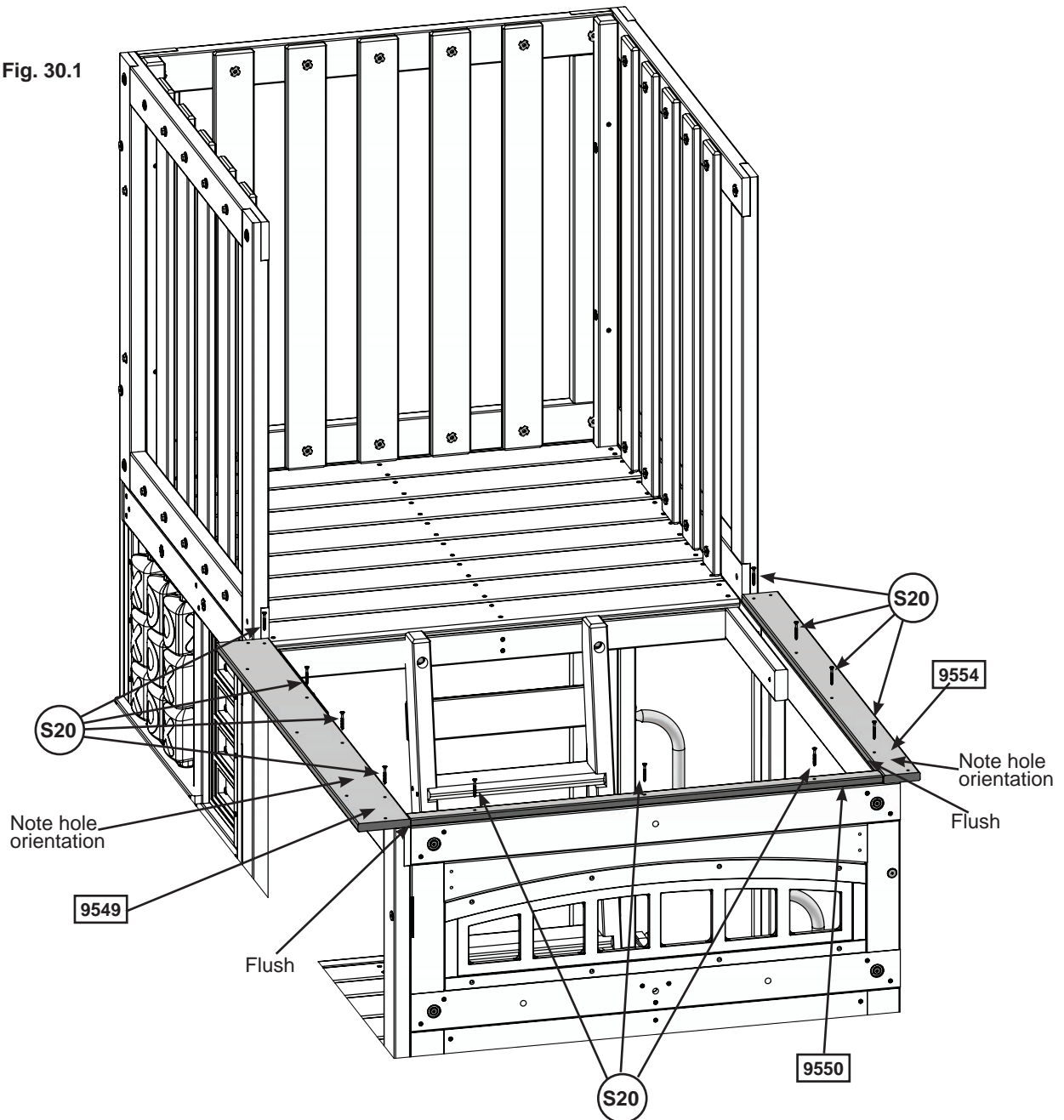

Wood Parts

- 1 x 9549 Roof Base 5/8 x 4 x 40"
- 1 x 9550 Narrow Roof base 5/8 x 1 1/4 x 35 11/16"
- 1 x 9554 Roof Base Narrow 5/8 x 2 3/4 x 40"

Hardware

- 11 x S20 #8 x 1-3/8" Wood Screw

Step 31: Attach Roof to Fort



A: With one person in the assembly and at least one helper on the ground, lift the roof assembly onto the roof base so that the Small Triangle Window is facing the front. (fig. 31.1 & 31.2)

B: Attach from the underside of the roof base using 5 (S20) #8 x 1-3/8" Wood Screws in the (9549) Roof Base and 2 (S20) #8 x 1- 3/8" Wood Screws in the (9554) Roof Base Narrow. (fig. 31.1 & 31.2)

Fig. 31.1
Back Side

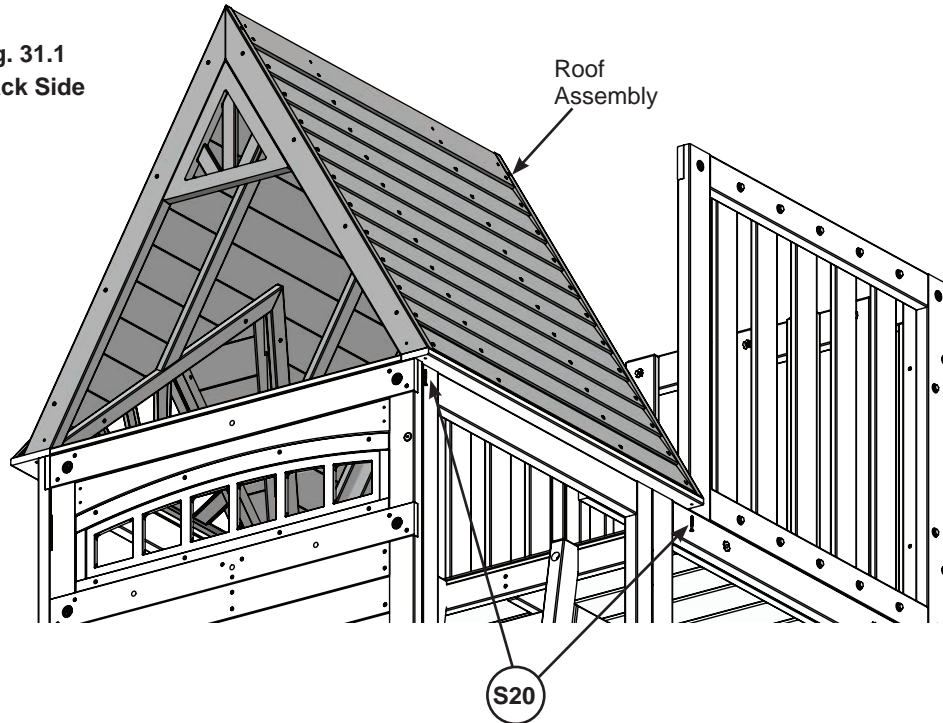
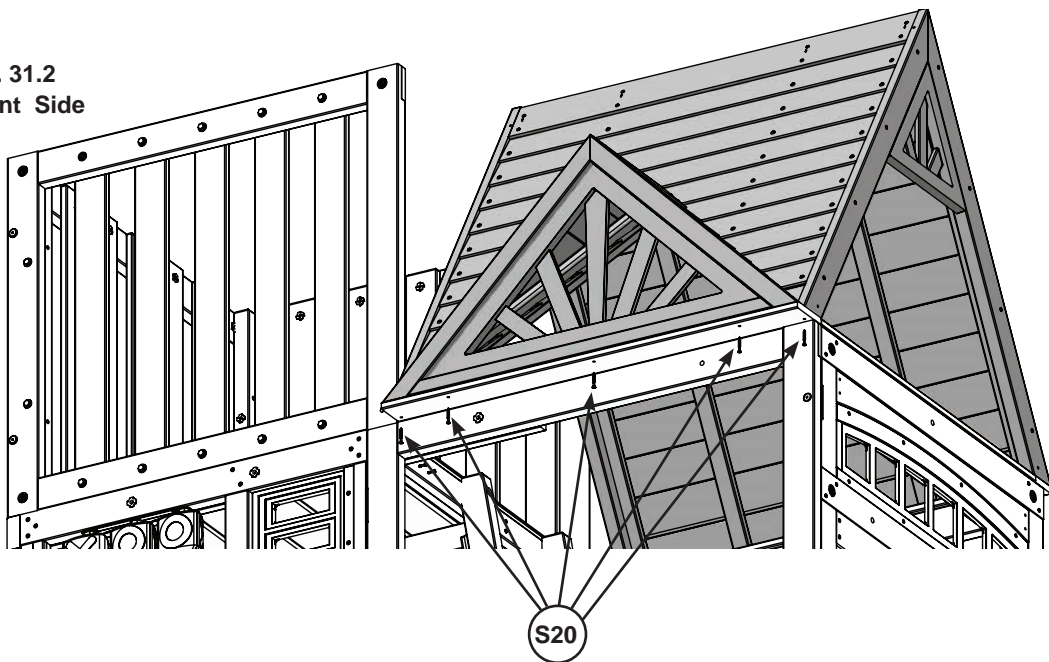

Fig. 31.2
Front Side



Hardware

7 x (S20) #8 x 1-3/8" Wood Screw

Step 32: Attach Roof Tie

A: On each side of the roof assembly, place a (9559) Roof Tie so that they are resting flush on the Roof Supports and are flush to the outside edges of the (9556) Fence Posts. Attach (9559) Roof Ties to the (9556) Fence Posts and to the Roof Supports using 3 (S4) #8 x 3" Wood Screws per board. (fig. 32.1)

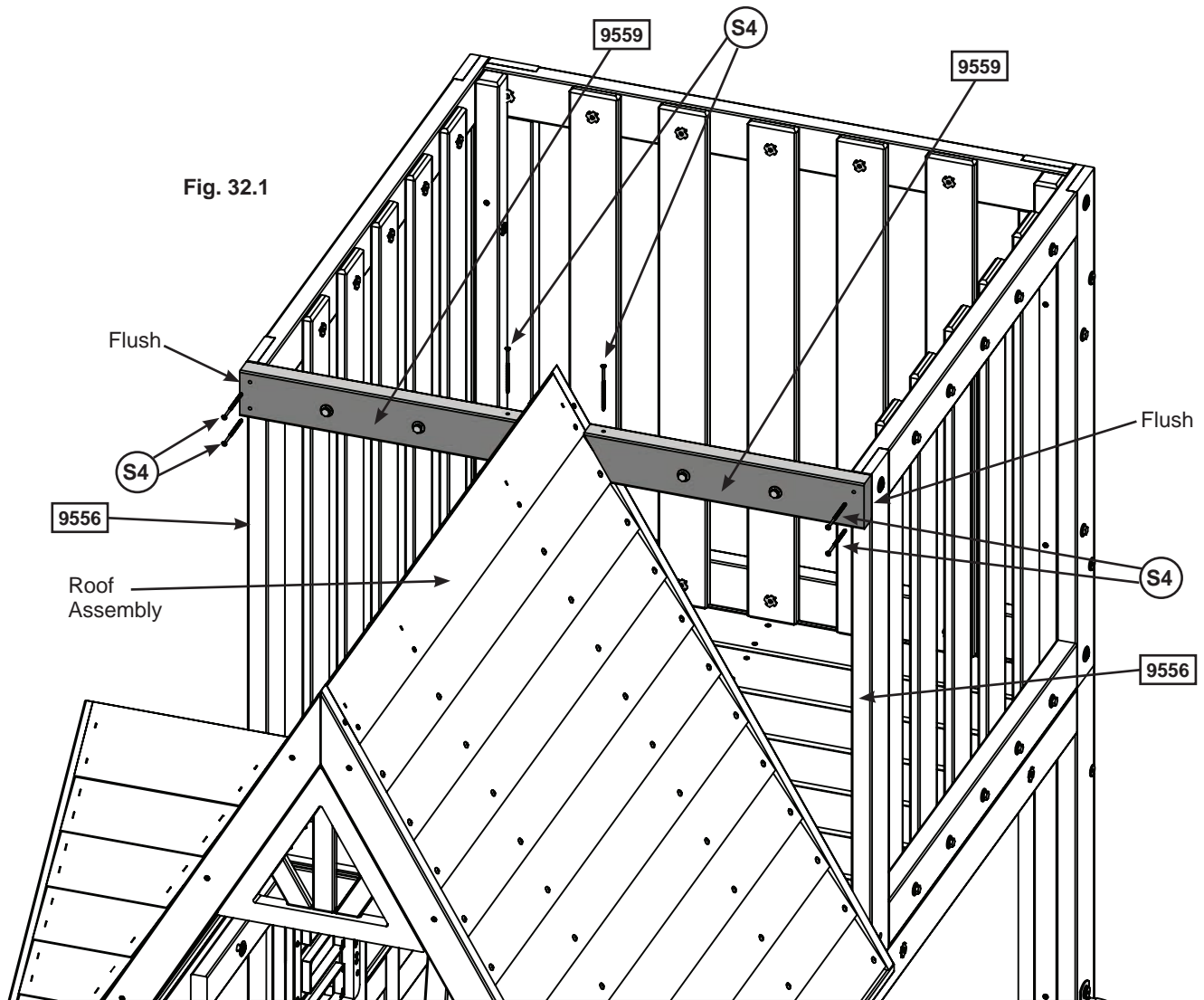

Wood Parts

2 x 9559 Roof Tie 1 1/4 x 3 x 17 3/16"

Hardware

6 x S4 #8 x 3" Wood Screw

Step 33: Attach Roof Support

A: From inside the assembly attach Roof Assembly to (9556) Fence Posts using 1 (S3) #8 x 2 1/2" Wood Screw per side. (fig. 33.1 & 33.2 & 33.3)

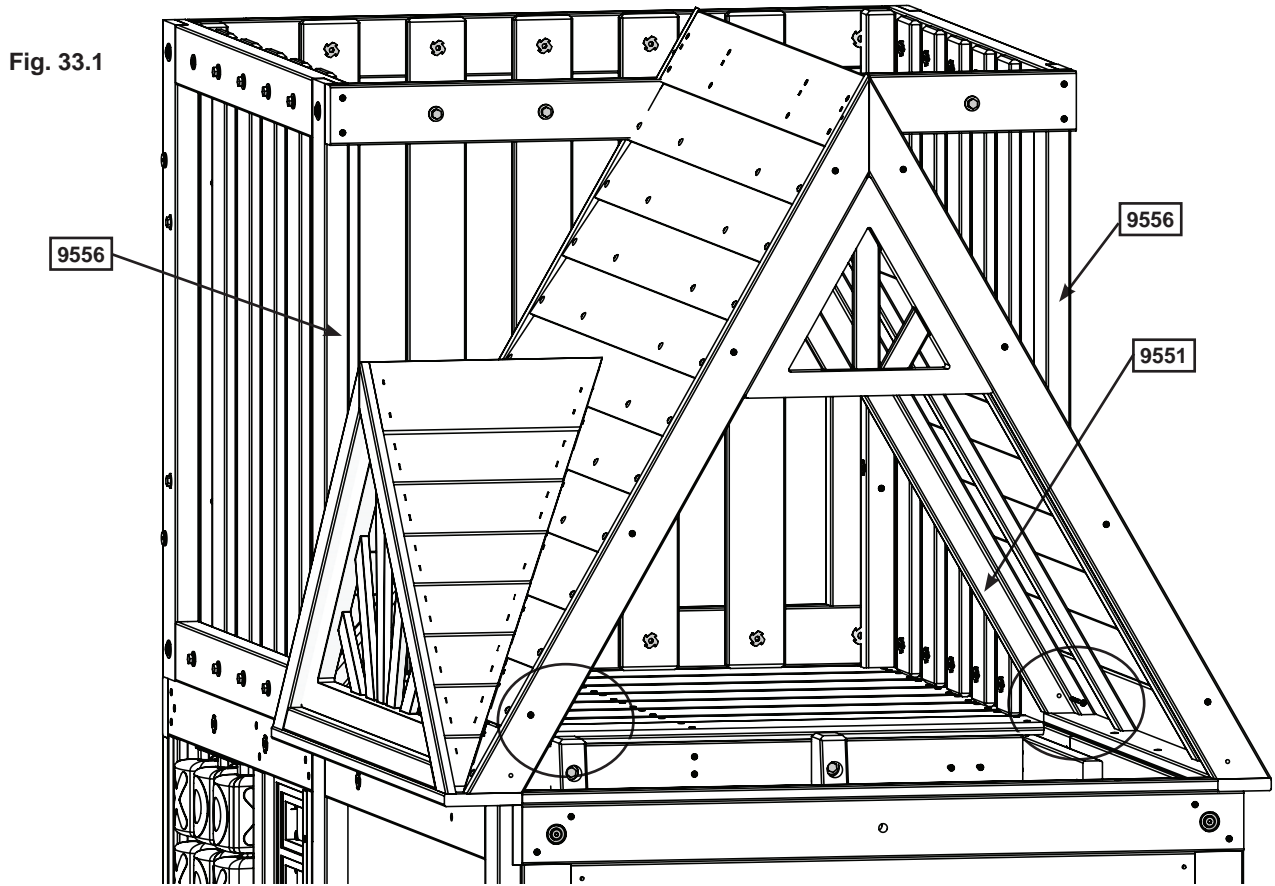

Fig. 33.2

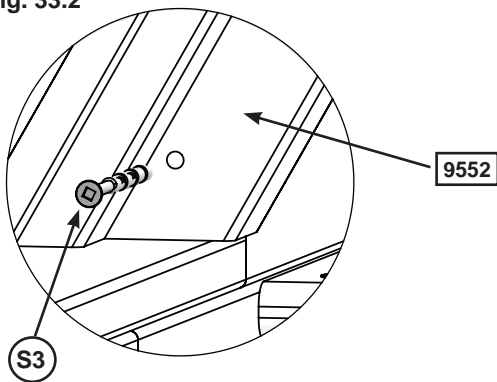
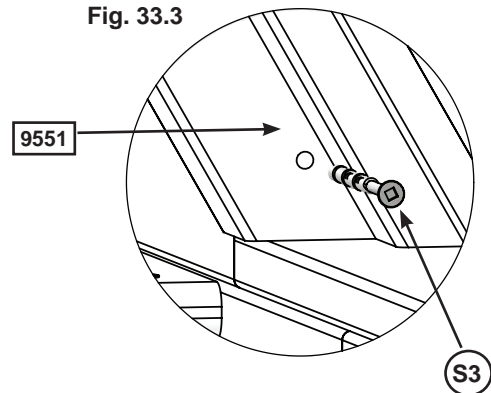

Fig. 33.3



Hardware

2 x (S3) #8 x 2-1/2" Wood Screw

Step 34: Attach Fence Board



A: From inside the upper deck, position a (9567) Fence Board Long A on each side of the Roof Assembly, making sure that the boards are flush to the top of (9559) Roof Tie. Attach each board using 1 (H2) 1/4 x 2" Hex Bolt (with flat washer, lock washer and t-nut) in the top hole and 2 (S20) #8 x 1- 3/8" Wood Screws in the bottom holes. (Fig. 34.1 & 34.3)

B: Using the 2 outside holes, install 2 (9568) Fence Board Long B's using 1 (H2) 1/4 x 2" Hex Bolt (with flat washer, lock washer and t-nut) and 2 (S20) #8 x 1- 3/8" Wood Screw per board. Boards should be flush to the top of (9559) Roof Tie. (Fig. 34.1 & 34.2 & 34.3 & 34.4).

C: Check to make sure each fence board is level, then attach the bottom of each fence board to the roof supports using 2 (S20) #8 x 1- 3/8" Wood Screws per board. (fig. 34.1, 34.2, 34.3 and 34.4)

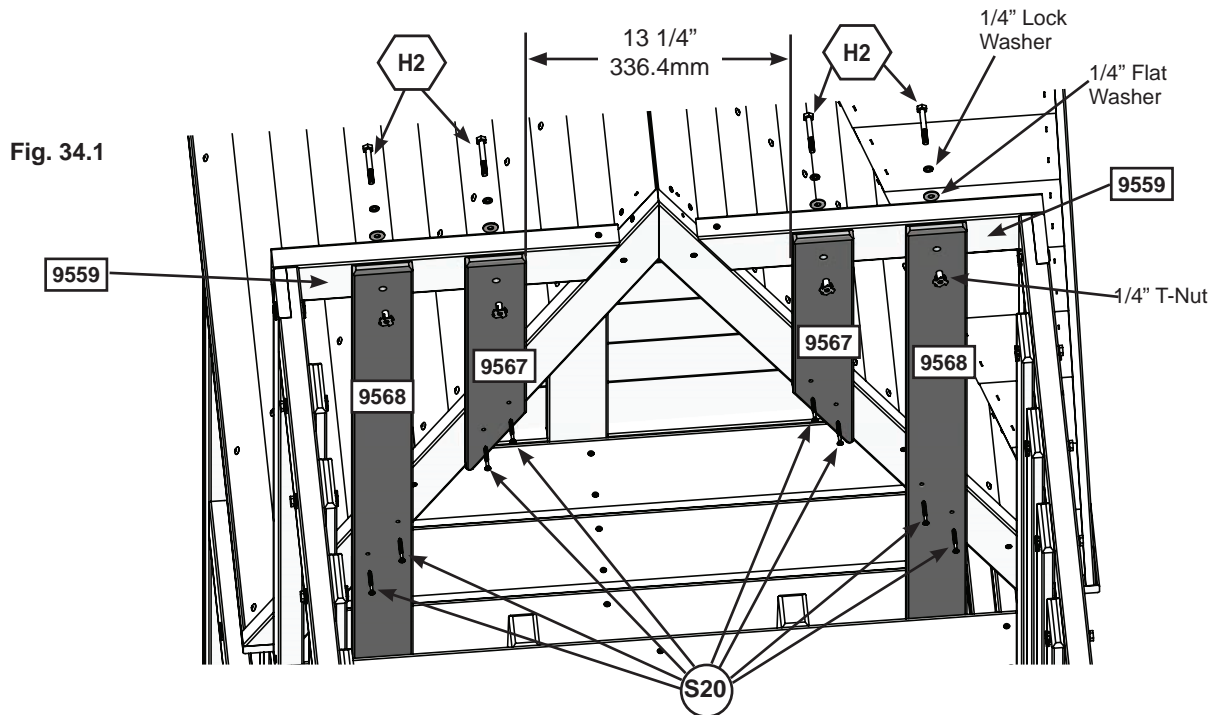

Fig. 34.3

Fig. 34.2

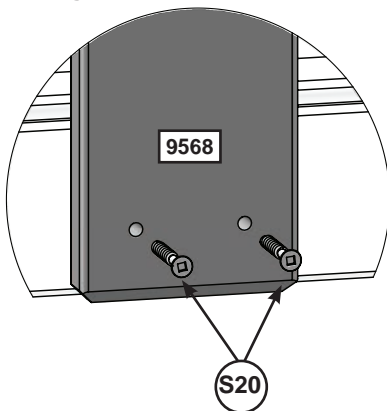
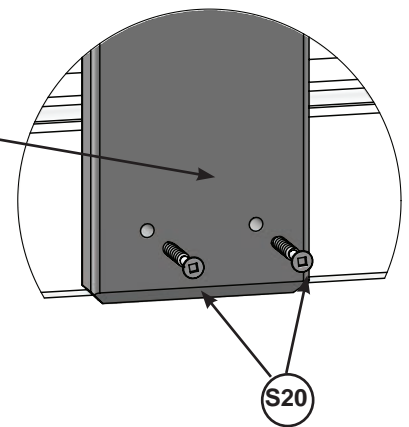
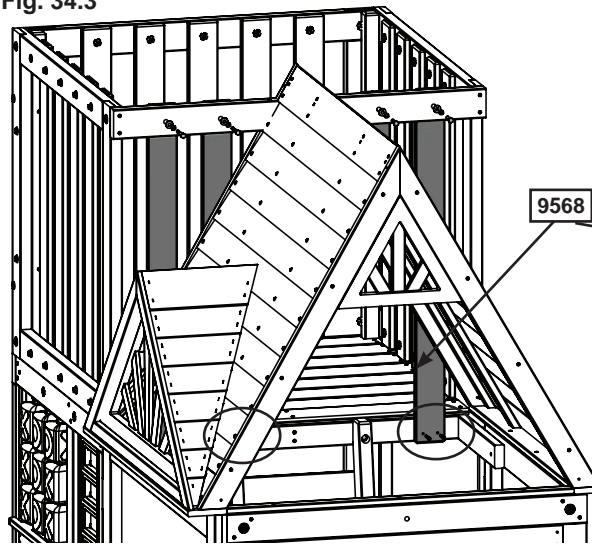

Fig. 34.4



Wood Parts

- 2 x 9567 Fence Board Long A 5/8 x 3 x 18 1/4"
- 2 x 9568 Fence Board Long B 5/8 x 3 x 36"

Hardware

- 4 x H2 1/4 x 2" Hex Bolts (with flat washer, lock washer and t-nut)
- 12 x S20 #8 x 1-3/8" Wood Screw

Step 35: Attach Roof Pull Part 1

A: Position (9578) Roof Pull between the 2 (9567) Fence Board Long A's making sure that it's flush to the top of (9559) Roof Tie. Attach using 8 (S20) #8 x 1- 3/8" Wood Screws. (fig. 35.1)

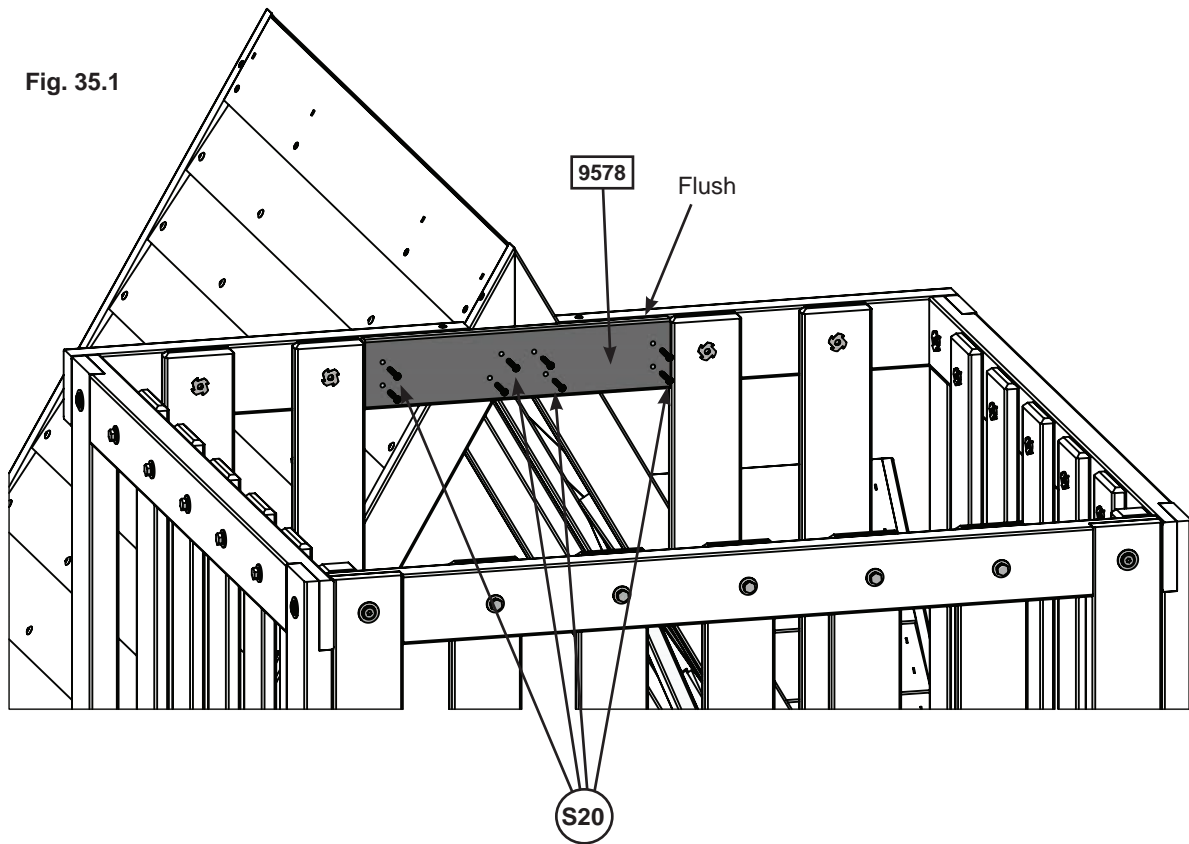

Wood Parts

1 x 9578 Roof Pull 5/8 x 3 x 13 1/16"

Hardware

8 x S20 #8 x 1-3/8" Wood Screw

Step 36: Slide Opening Assembly



A: Position 2 (9575) Slide Posts so the notches are facing up, with the smaller notches are the bottom. Place (9573) Slide Bottom into the smaller bottom notches and attach using 1 (WB2) 5/16 x 1- 3/8" Wafer Head Bolt (with flat washer and t-nut) per side. (fig. 36.1)

B: Place (9574) Slide Top into the top notches, check to make sure that the assembly is square and then attach using 1 (WB2) 5/16 x 1- 3/8" Wafer Head Screw (with flat washer and t-nut) and 2 (S1) #8 x 1- 1/8" Wood Screws per side. (fig. 36.1)

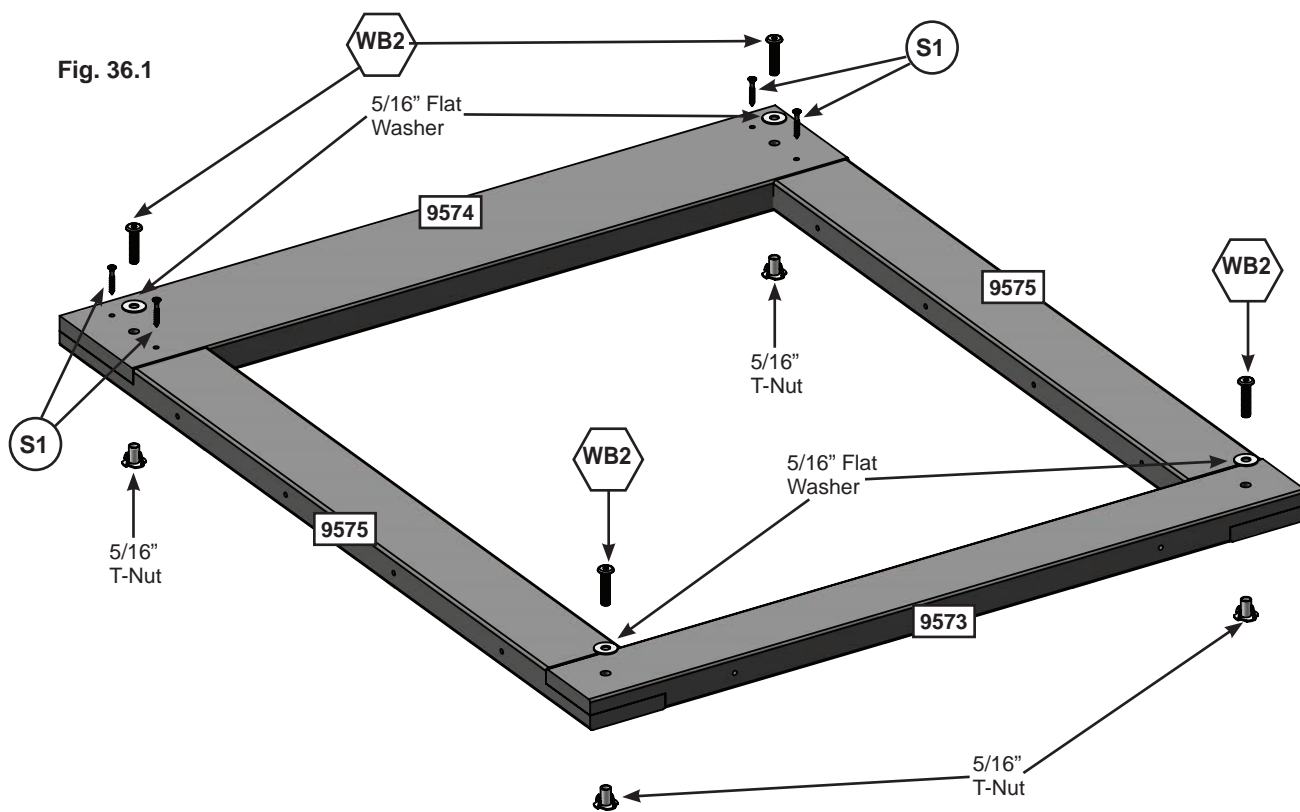

Wood Parts

- 2 x 9575 Slide Post 1 1/4 x 3 1/4 x 36"
- 1 x 9574 Slide Top 1 1/4 x 5 x 30 7/8"
- 1 x 9573 Slide Bottom 1 1/4 x 3 x 30 13/16"

Hardware

- 4 x WB2 5/16 x 1-3/8" Wafer Head Bolt (5/16" flat washer, 5/16" t-nut)
- 4 x S1 #8 x 1-1/8" Wood Screw

Step 37: Attach Slide Opening Assembly to Fort Part 1

A: Place the Slide Entrance Assembly into the opening in the slide end panel and attach using 11 (S24) #10 x 4" Wood Screws in the bottom and sides of the assembly. (Fig. 37.1)

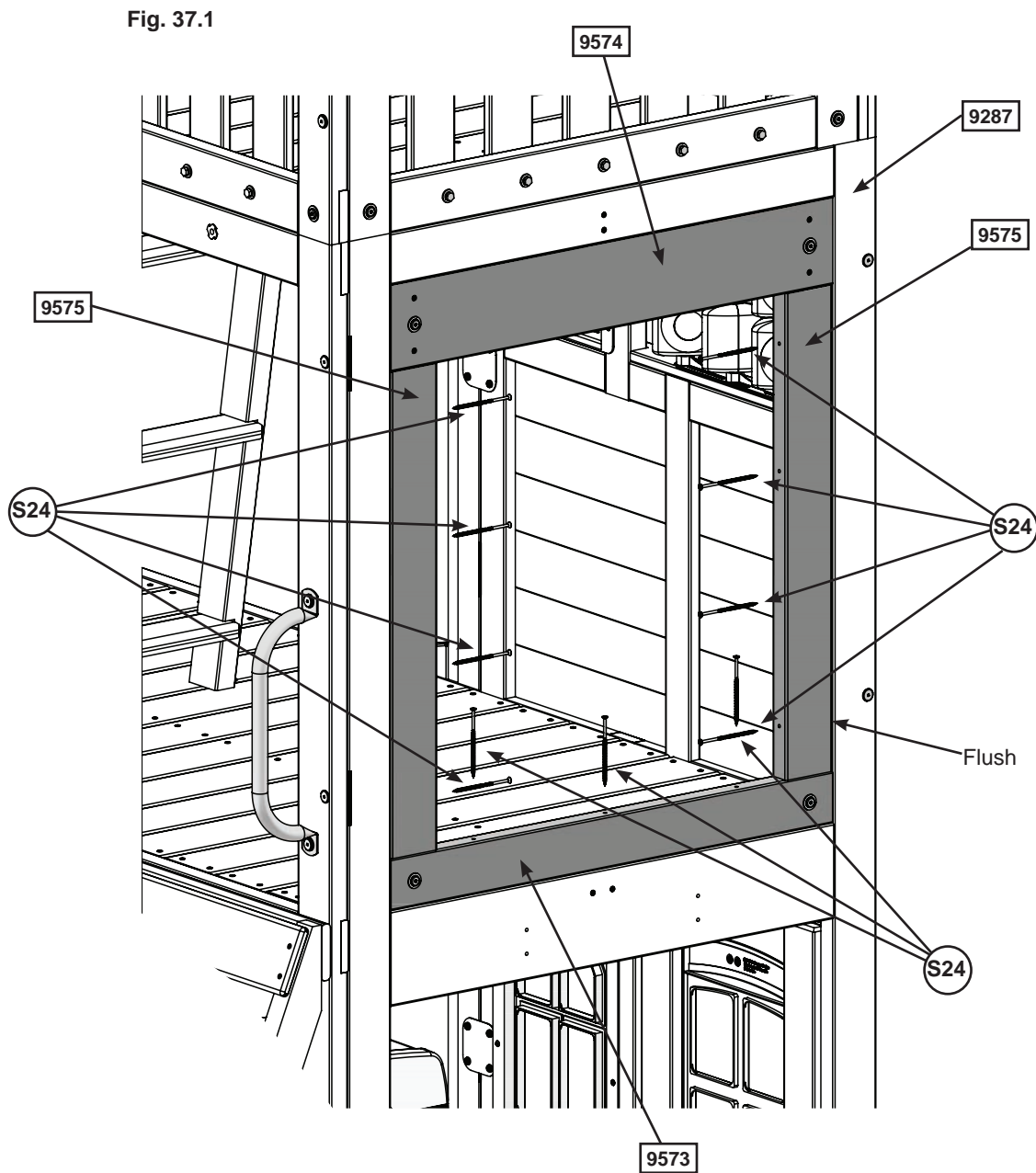

Hardware

11 x  #10 x 4" Wood Screw

Step 37: Attach Slide Opening Assembly to Fort Part 2

B: From inside the assembly, place a Flat Panel Bracket at the top end of the Slide Entrance Assembly so that the brackets are centered over the (9574) Slide Top, (9575) Slide Posts and (9581) Cross Frame. Attach each bracket using 4 (S8) #12 x 3/4" Pan Screws. (fig. 37.2)

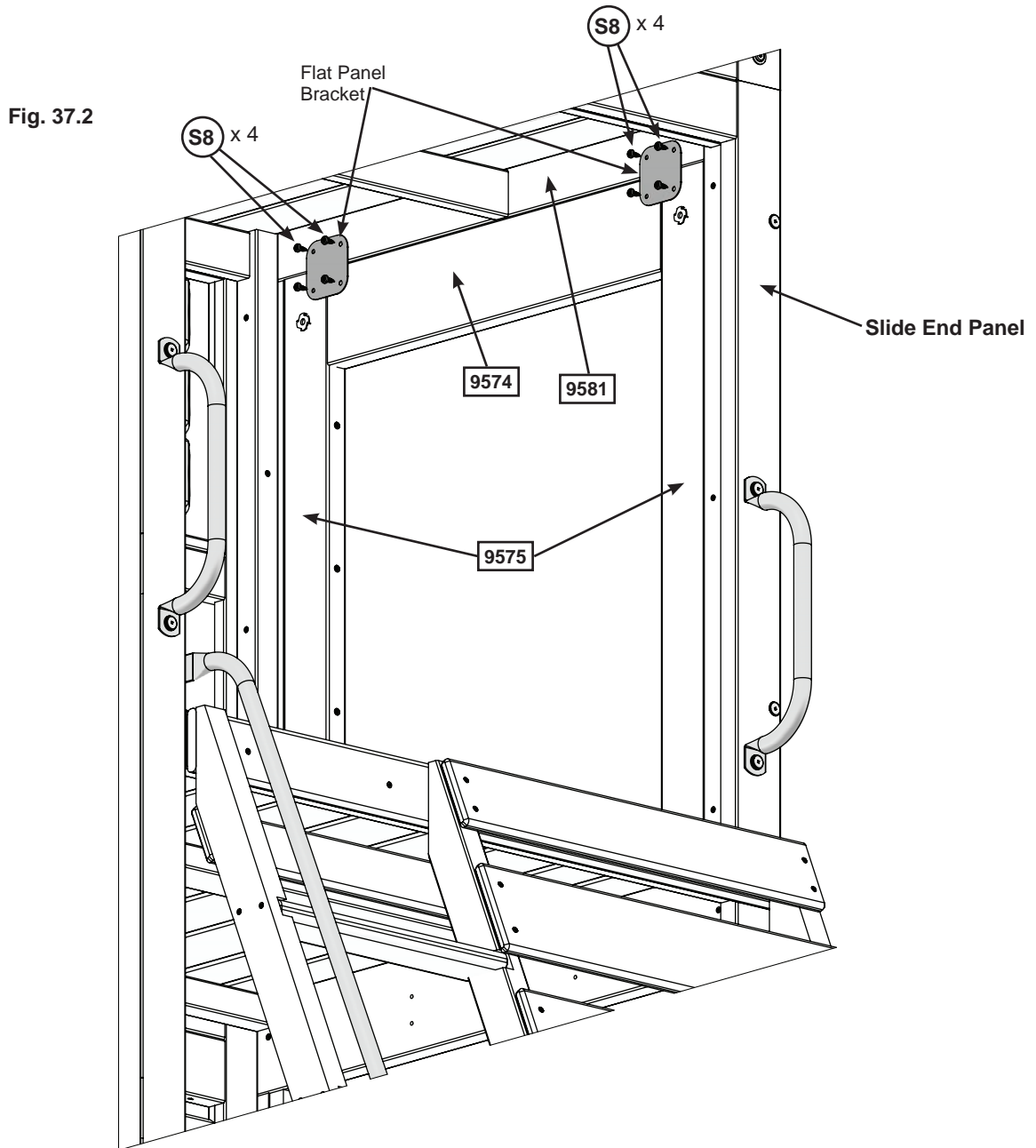

Hardware

8 x (S8) #12 x 3/4" Pan Screw

Other Parts

2 x Flat Panel Bracket

Step 38: Slide Section Assemblies Part 1



Note: When installing Pan Bolts make sure to look at holes so bolts go through the side with the round recess and the lock nuts go through the side with the hexagonal recess. (Fig. 38.3).

A: Fit 2 TNR2 Slide Elbows together and attach with 8 (PB1) 1/4 x 3/4" Pan Bolts (with lock nut) as shown in (Fig. 38.1). It is very important to attach bolts as indicated.

B: Repeat Step A 3 more times to create 4 Elbow Sections in total.

C: Attach TNR3 Extend Flange RT Flange and TNR3 Extend Flange LT together using 9 (PB1) 1/4 x 3/4" Pan Bolts (with lock nut) as shown in (Fig. 38.2). This creates the Flange Assembly.

Fig. 38.1

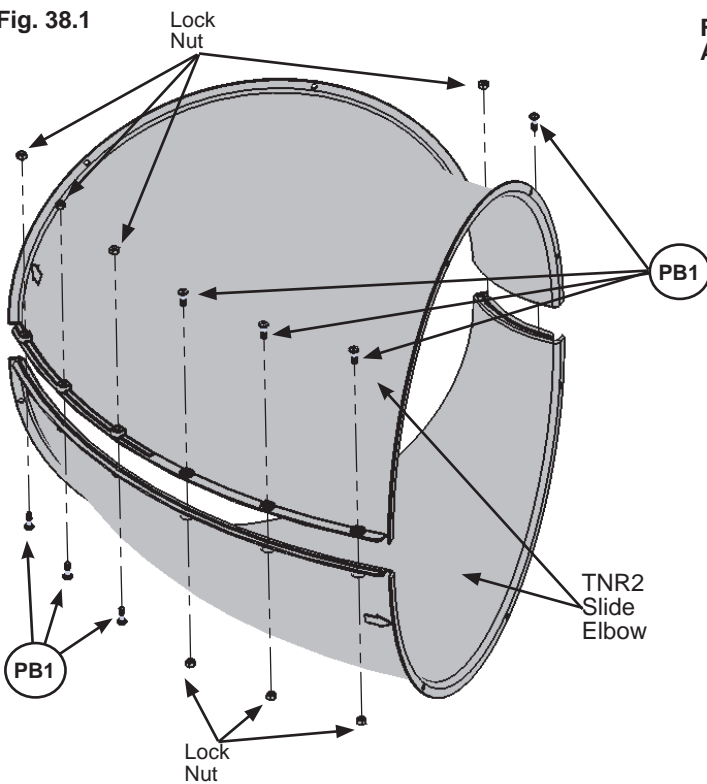

Fig. 38.2

Flange Assembly

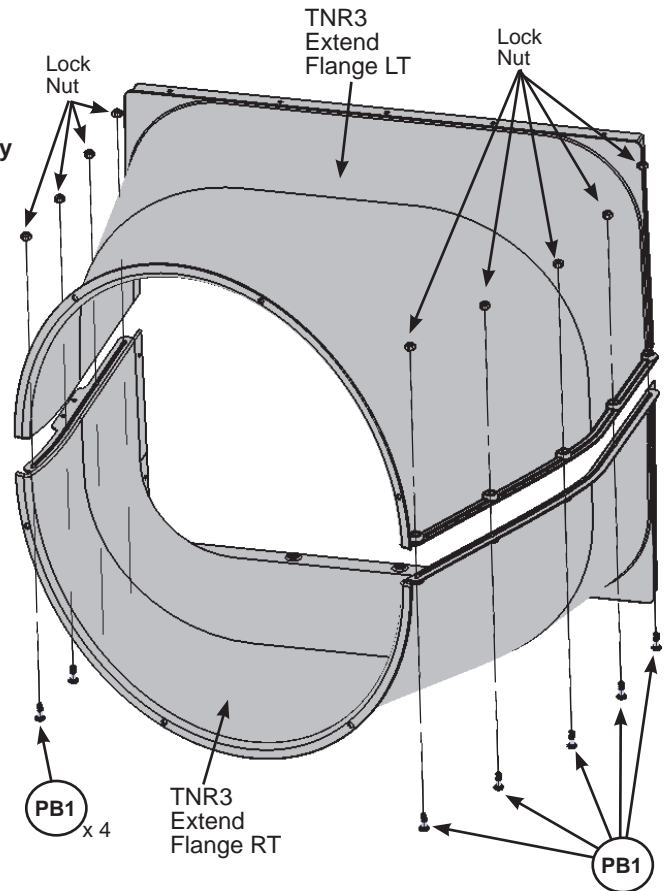
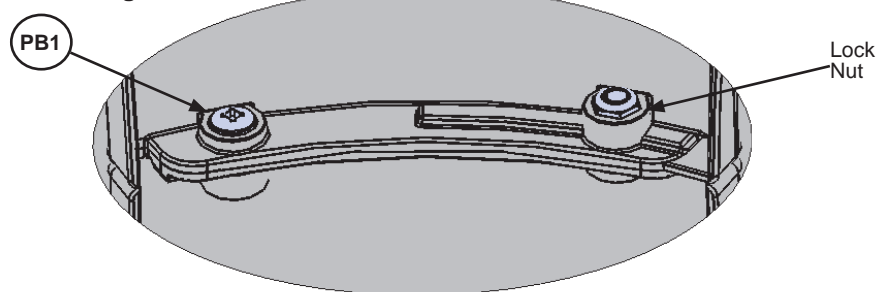

Fig. 38.3



Use a 7/16" open end wrench for nuts

Hardware

41 x (PB1) 1/4 x 3/4" Pan Bolt
(1/4" lock nut)

Other Parts

1 x TNR3 Extend Flange RT
1 x TNR3 Extend Flange LT
8 x TNR2 Slide Elbow

Step 38: Slide Section Assemblies

Part 2

Note: When installing Pan Bolts make sure to look at holes so bolts go through the side with the round recess and the lock nuts go through the side with the hexagonal recess. (fig. 38.3)

D: Attach TNR2 Slide Exit Top and the remaining TNR2 Slide Elbow together using 8 (PB1) 1/4 x 3/4" Pan Bolts (with lock nut) as shown in fig. 38.4. It is very important to attach bolts as indicated. This creates the Exit Elbow Assembly.

Fig. 38.4

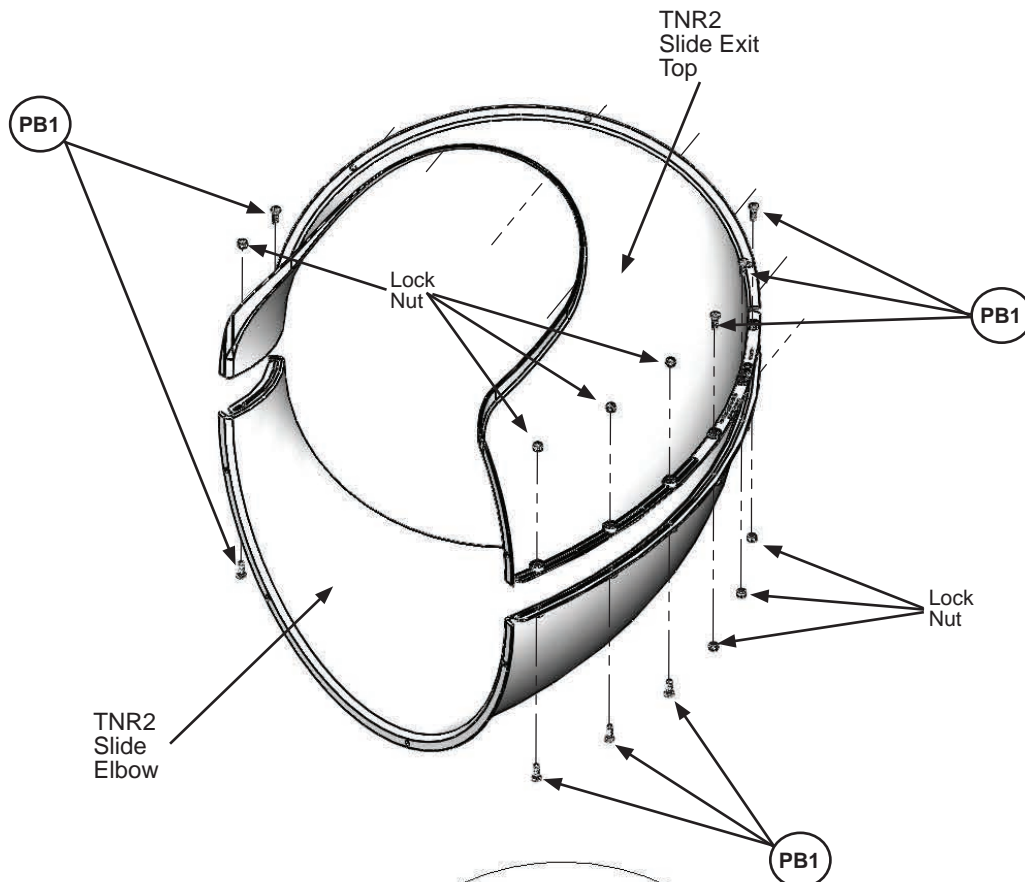
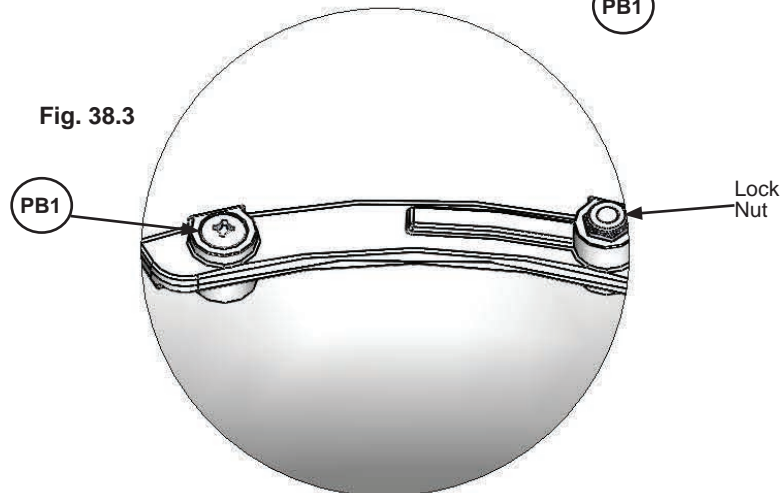

Fig. 38.3



Hardware

8 x (PB1) 1/4 x 3/4" Pan Bolt
(1/4" lock nut)

Other Parts

1 x TNR2 Slide Exit Top
1 x TNR2 Slide Elbow

Step 39: Attach Flange Assembly to Fort Part 1



A: With a helper place the Flange Assembly flush to the slide entrance assembly as shown in fig. 39.1, then pre-drill 1/8" pilot holes in (9574) Slide Top for the 4 upper mounting locations (approximate spots where circles are on figure), making sure the pre-drilled holes are a minimum of 1" deep. (fig. 39.1)

B: Attach Flange Assembly to (9574) Slide Top using 4 (S7) #12 x 2" Pan Screws (with #12 Screw Bezel) in the pre-drilled holes. (fig. 39.1). Make sure the flat surfaces of the Flange Assembly are flush to (9573) Slide Bottom and both sides of (9575) Side Posts as shown in (fig. 39.1 & 39.2 & 39.3)

C: Attach the Flange Assembly flush to bottom of (9573) Slide Bottom using 4 (S7) #12 x 2" Pan Screws (with #12 Screw Bezel) and to both sides of (9575) Slide Posts using 5 (S6) #12 x 1" Pan Screws per side. (fig. 39.1 & 39.2)

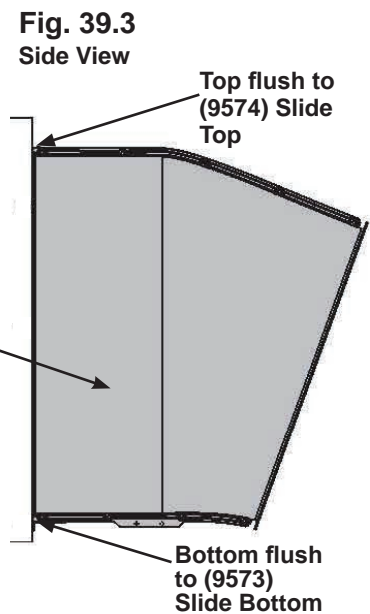
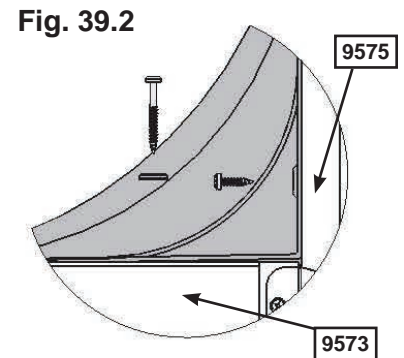
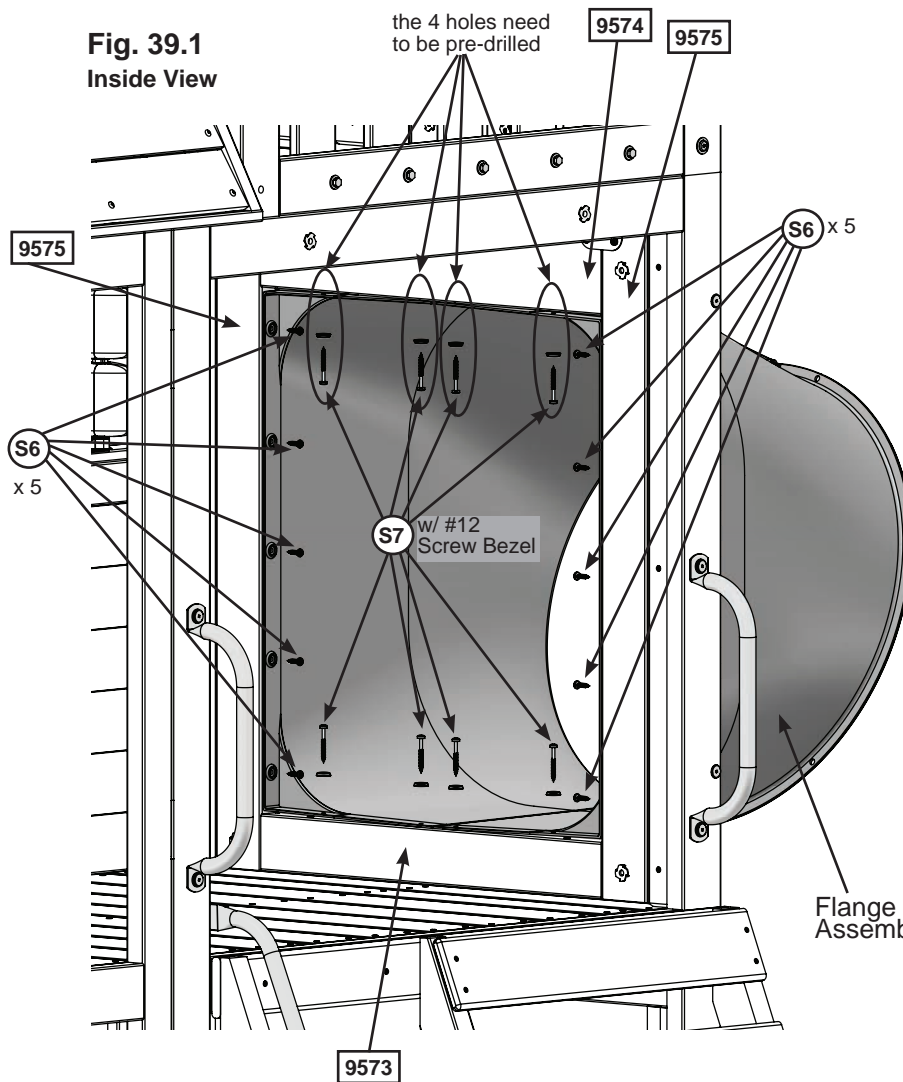

Hardware

- 10 x #12 x 1" Pan Screw
- 8 x #12 x 2" Pan Screw
(with #12 Screw Bezel)

Step 39: Attach Flange Assembly to Fort Part 2



D: Place (9576) Gusset centred and tight to Slide End Panel and attach to Flange Assembly with 2 (S6) #12 x 1" Pan Screws. (fig. 39.4 & 39.5)

E: Pre-drill pilot hole with a 3/16" drill bit then attach (9576) Gusset to Slide End Panel with 1 (WL5) 1/4 x 2-1/2" Wafer Lag (with flat washer). (fig. 39.4 & 39.5)

Fig. 39.4

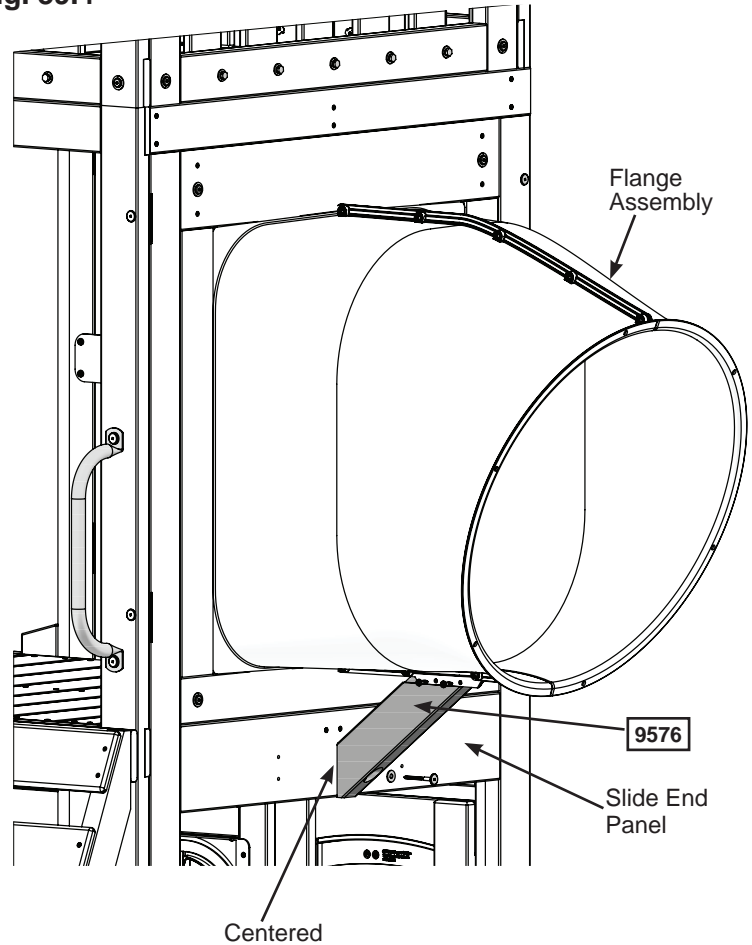
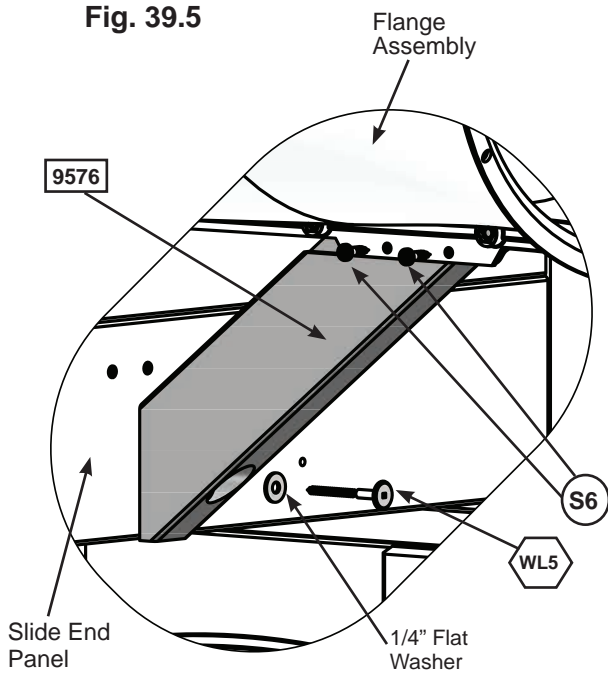

Fig. 39.5



Wood Parts

1 x **9576** Gusset 1 1/4 x 3 x 13 3/4"

Hardware

2 x **S6** #12 x 1" Pan Screw

1 x **WL5** 1/4 x 2-1/2" Wafer Lag (1/4" flat washer)

Step 40: Attach Elbow Assembly to Flange Assembly

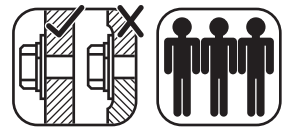

Note: Keep all bolts loose until further step.

A: Fit one of the Elbow Assemblies to the Flange Assembly by lining up the arrows on each assembly. Attach Elbow Assembly to Flange Assembly using 6 (PB1) $\frac{1}{4}$ x $\frac{3}{4}$ " Pan Bolts and Square Lock Nut. (fig. 40.1, 40.2 and 40.3)

B: Attach one of the Elbow assemblies to another Elbow Assembly making sure to line up the arrows on each assembly. Attach 6 ($\frac{1}{4}$ x 12.7mm) Pan Bolt with Square Lock Nut. Repeat this instruction for 2 more. (fig. 40.2 and 40.3)

Use Quadrex Driver as a guide pin for each hole before inserting bolt.

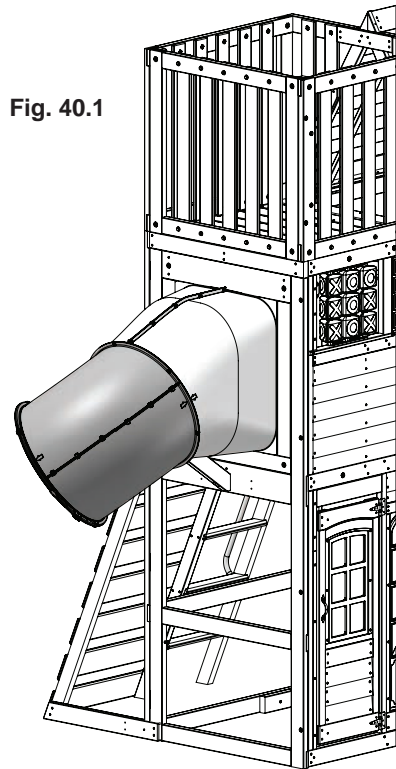

Fig. 40.1

Fig. 40.2
Top Slide Bolt Holes

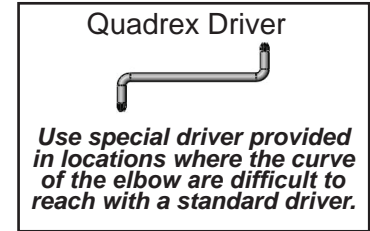
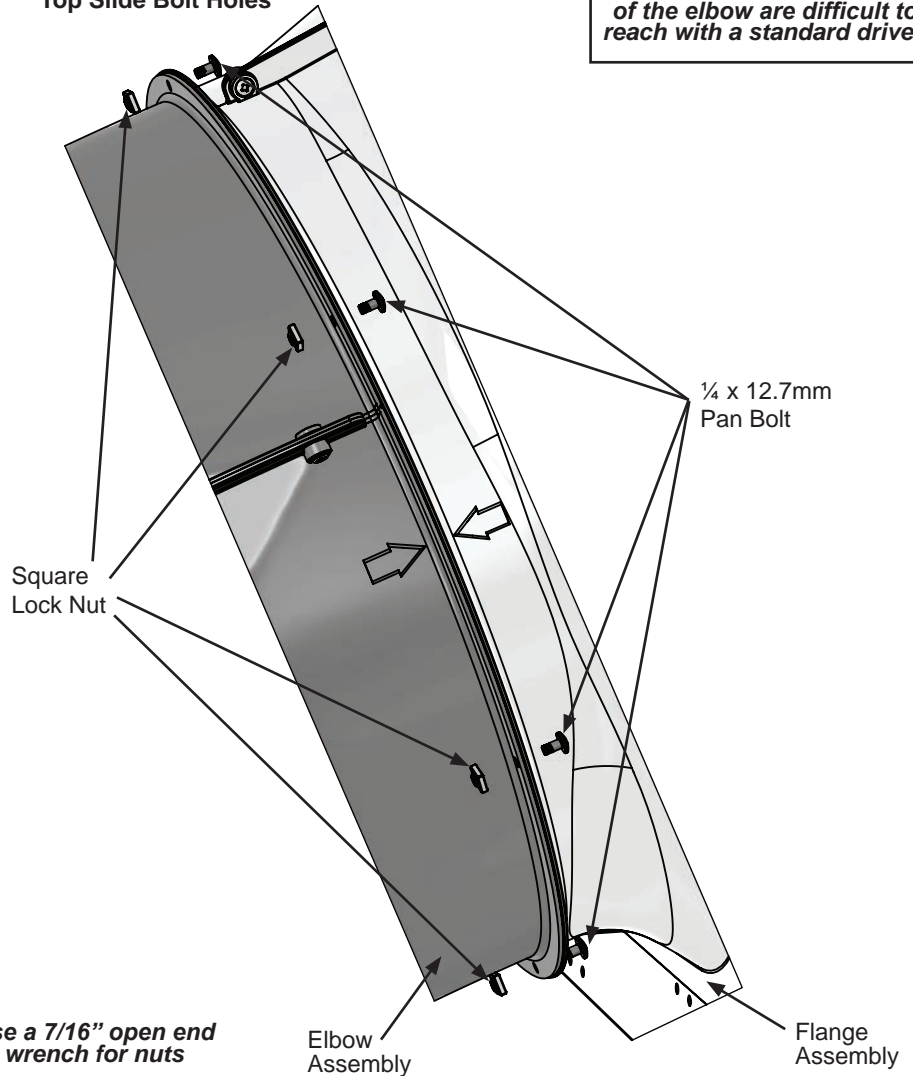
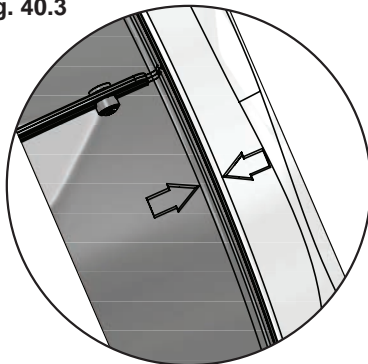

Fig. 40.3



Align each elbow using the molded arrows.

Use a 7/16" open end wrench for nuts

Other Parts

- 1 x Quadrex Driver
- 24 x $\frac{1}{4}$ x 12.7mm Pan Bolt
- 24 x $\frac{1}{4}$ " Square Lock Nut

Step 41: Attach TNR 3 Slide Exit to Elbow Assembly



A: Insert flange of Exit Elbow Assembly (slide elbow) into the slots on TNR3 Short Exit. (fig. 41.1)

B: Rotate Slide Exit and use Quadrex Driver as a guide pin so the holes are aligned and attach with 5 (PB1) 1/4 x 3/4" Pan Bolts (with lock nuts) starting with the bottom middle hole and working up each side. (fig. 41.2 and 41.3)

C: At this point make sure all the slide bolts are tight.

Use a 7/16" open end wrench to hold nut and then tighten bolt with Quadrex Driver.

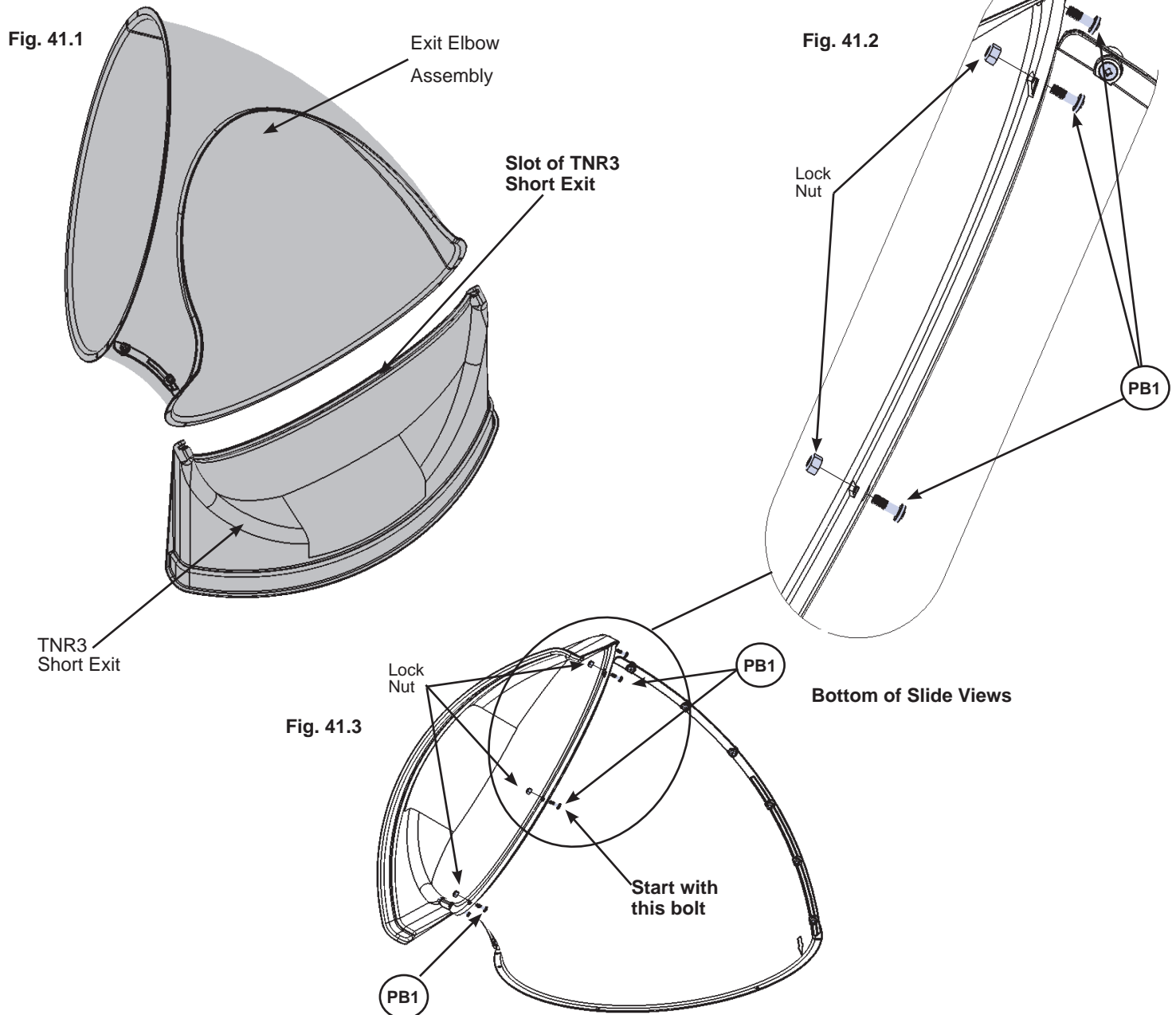

Hardware

5 x (PB1) 1/4 x 3/4" Pan Bolt
(1/4" lock nut)

Other Parts

1 x TNR3 Short Exit

Step 42: Attach Exit End Assembly to Fort



A: Fit the Exit End Assembly to the last Elbow Assembly by lining up the arrows on each assembly. Notice the elbow orientation. (fig. 42.1). Attach with 6 (1/4 x 12.7)mm Pan Bolts and Square Lock Nuts. (fig. 42.2)

Fig. 42.1

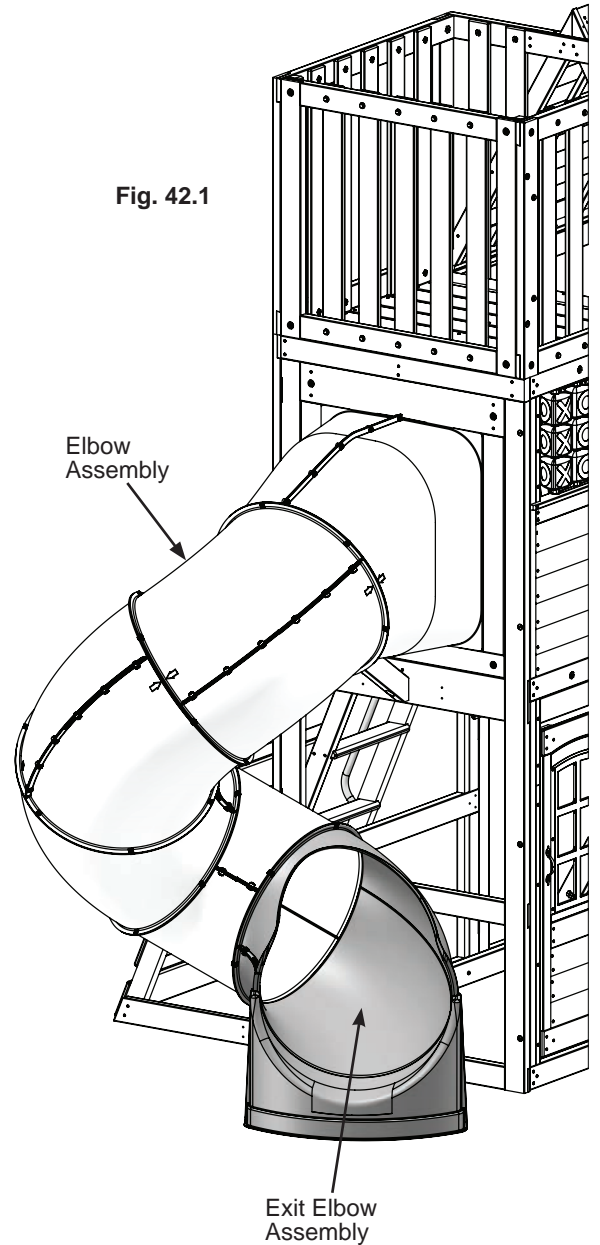
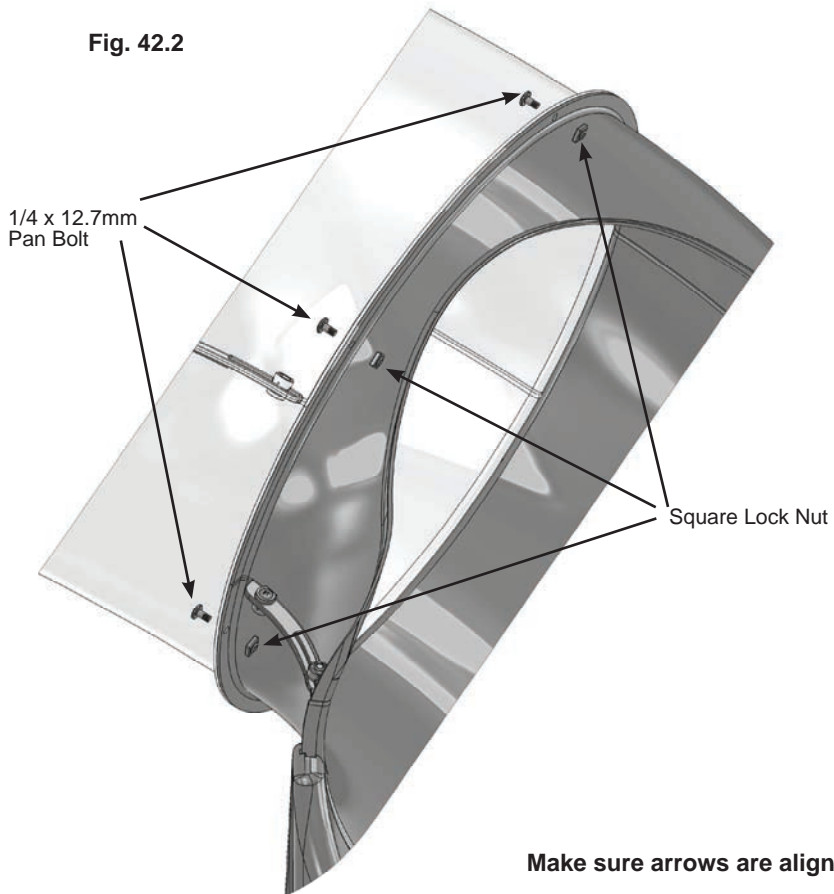

Fig. 42.2



Other Parts

- 6 x 1/4" x 12.7mm Pan Bolt
- 6 x 1/4" Square Lock Nut

Step 43: Attach TNR 4 Clamp Rings



A: Place 2 TNR4 Clamp Rings around each joint making sure to match the arrows with the end of the Clamp Ring as shown in (fig. 43.1 & 43.2).

B: Connect TNR4 Clamp Rings in 2 spots using 1 (PB6) 1/4 x 1" Pan Bolt (with lock nut) per side. (fig. 43.3)

Note: When installing Pan Bolts make sure to look at holes so bolts go through the side with the round recess and the lock nuts go through the side with the hexagonal recess.

Fig. 43.1

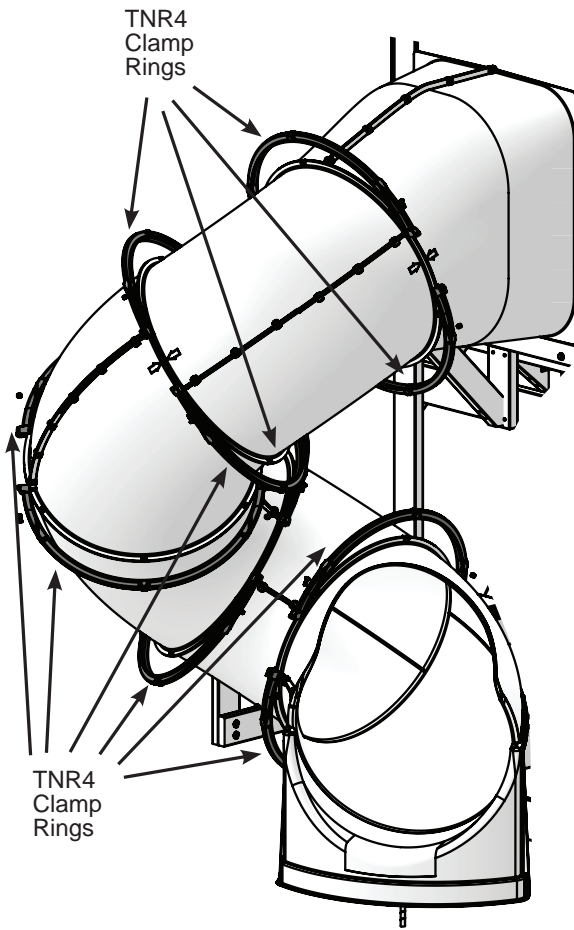

Note: For ease of assembly the bottom set of clamp rings can be turned 90 degrees to install bolts.

Fig. 43.2

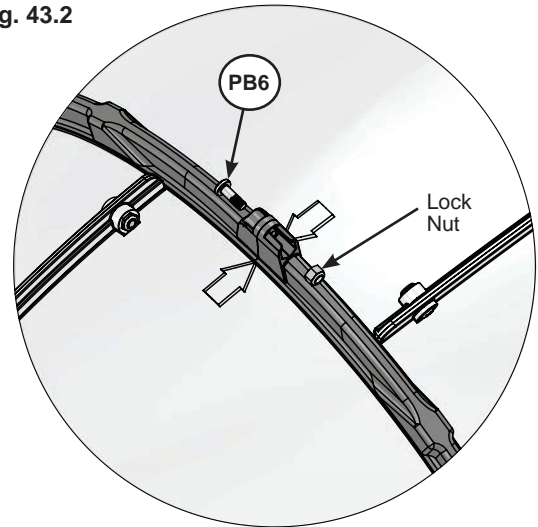

Make sure arrows are aligned

Fig. 43.3

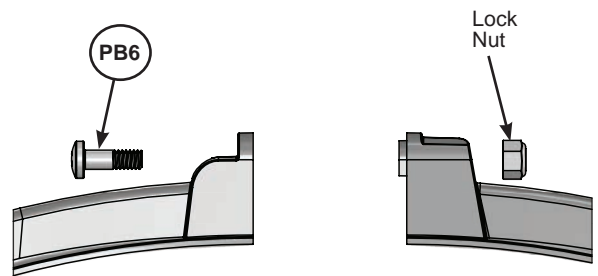

After the clamp rings are attached to the elbows, fasten them end to end with two pan bolts and lock nuts

Hardware

10 x  1/4 x 1" Pan Bolt
(1/4" lock nut)

Other Parts

10 x TNR4 Clamp Ring

Step 44: Attach TNR 3 Slide to Fort



A: On the fourth attached Elbow Assembly remove the pan bolt and nut which is facing the fort (installed in Step 38). (fig. 44.1) The bolt will no longer be needed, but keep the lock nut.

B: Loosely attach TNR3 Tube Support (at the slightly bent end) to the slide seam using 1 (PB6) 1/4 x 1" Pan Bolt (with flat washer and the previously removed lock nut). (fig. 44.2)

C: Rotate TNR3 Tube Support and attach to Slide End Panel using 1 (S6) #12 x 1" Pan Screw as shown in (fig. 44.2).

D: Fully tighten screw and bolt.

Fig. 44.2

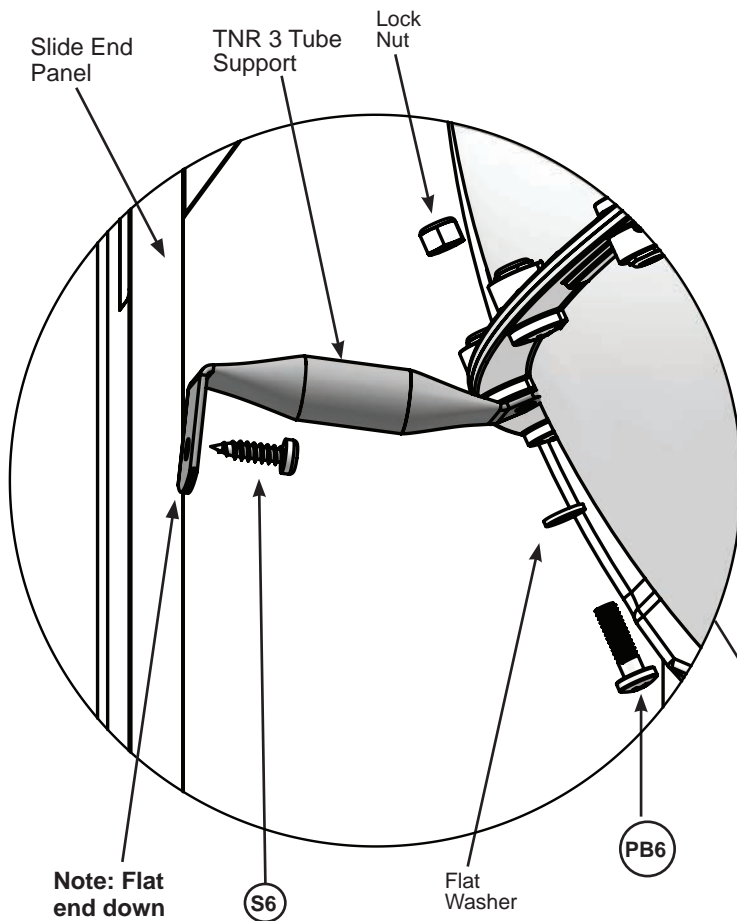
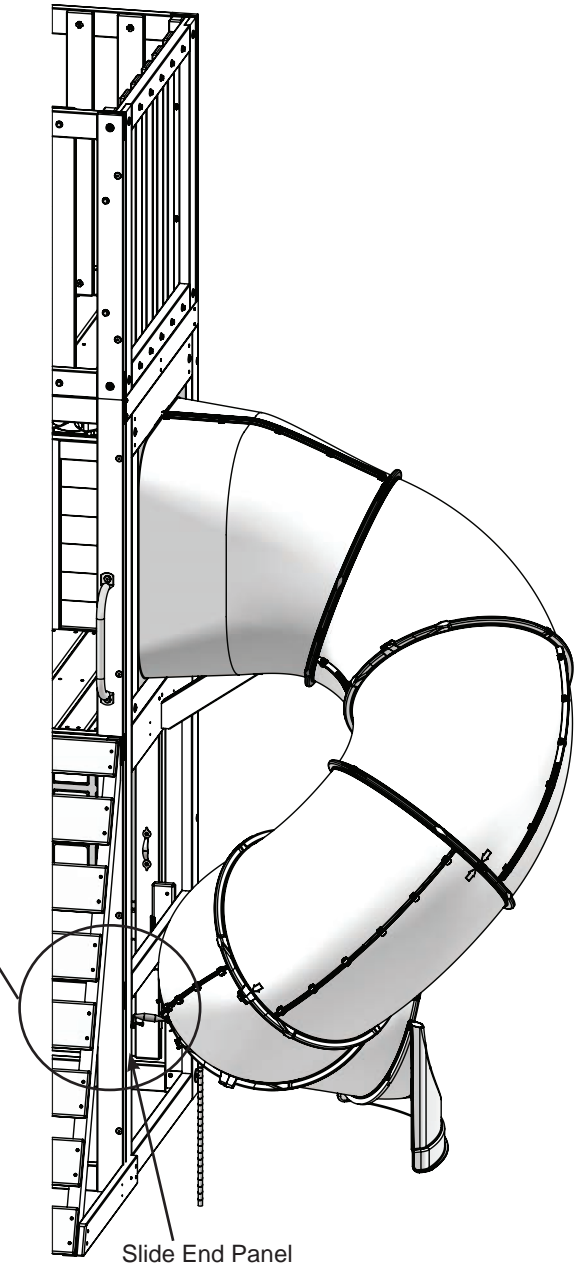

Fig. 44.1



Remove PB1 (1/4 x 3/4" Pan Bolt) first then install PB6 (1/4 x 1" Pan Bolt with flat washer)

Hardware

- 1 x (S6) #12 x 1" Pan Screw
- 1 x (PB6) 1/4 x 1" Pan Bolt (1/4" flat washer & 1/4" lock nut - previously removed)

Other Parts

- 1 x TNR3 Tube Support

Step 45: TNR Brace Assembly

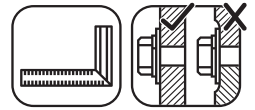

A: Attach (9680) TNR Upright to (9577) TNR Ground Brace with 1 (H8) 1/4 x 4-1/4" Hex Bolt (with lock washer, flat washer and t-nut) in the top hole. Make sure both boards are square then attach with 1 (S4) #8 x 3" Wood Screw. (fig. 45.1)

Fig. 45.1

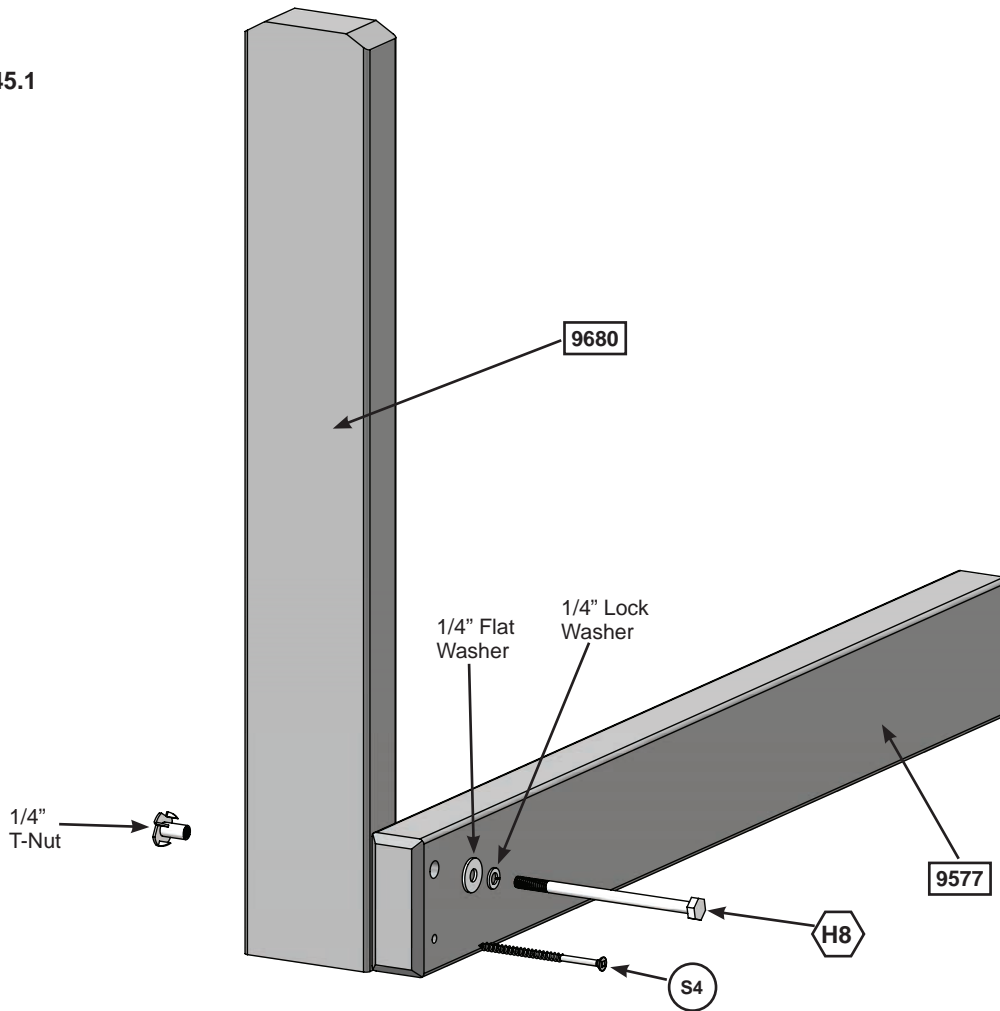

Wood Parts

- 1 x 9577 TNR Ground Brace 1 1/4 x 3 x 25 3/16"
- 1 x 9680 TNR Upright 1 1/4 x 3 x 20 1/4"

Hardware

- 1 x S4 #8 x 3" Wood Screw
- 1 x H8 1/4 x 4-1/4" Hex Bolt (1/4" lock washer, 1/4" flat washer, 1/4" t-nut)

Step 46: Attach Elbow Assemblies and TNR4 Slide

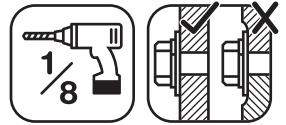

- A:** Attach (9577) TNR Ground Brace to (9548) Ground Brace using with 2 (S4) #8 x 3" Wood Screws. (fig. 46.1).
- B:** Place 1 TNR4 Post Mount Clamp on either side of the Clamp Ring so that the bent tops clip in behind the Clamp Ring. (fig. 46.2)
- C:** Insert the TNR4 Post Mount Base in between the 2 Post Mount Clamps and screw all pieces together using 1 1/4 x 14.5mm Pan Head Bolt and Square Nylock Nut. (fig. 46.2)
- D:** Attach TNR4 Post Mount Base to (9680) TNR Upright, pre-drill with a 1/8" drill bit then attach with 2 (S6) #12 x 1" Pan Screws. (fig. 46.2)
- E:** Attach the Post Mount Clamp to the clamp ring using 1 (S37) #7 x 5/8" Pan Screw. (fig. 46.2)

Fig. 46.2

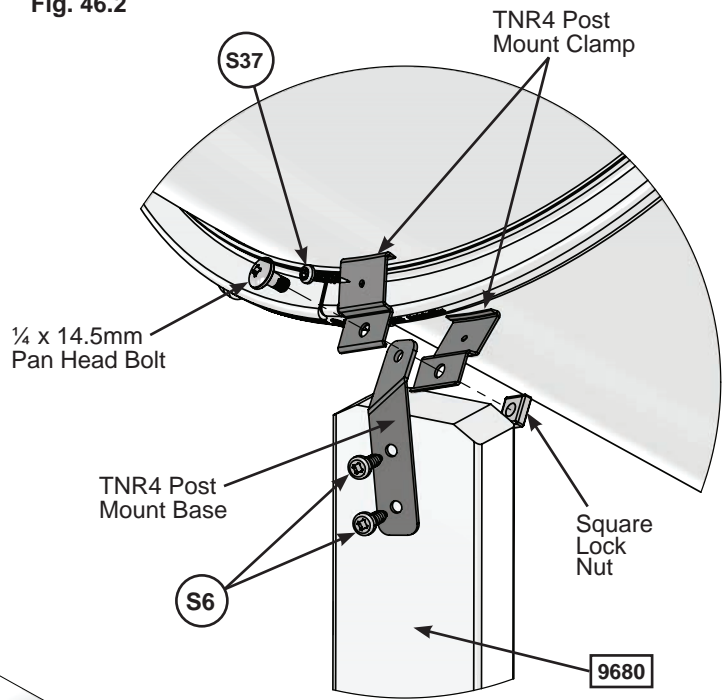
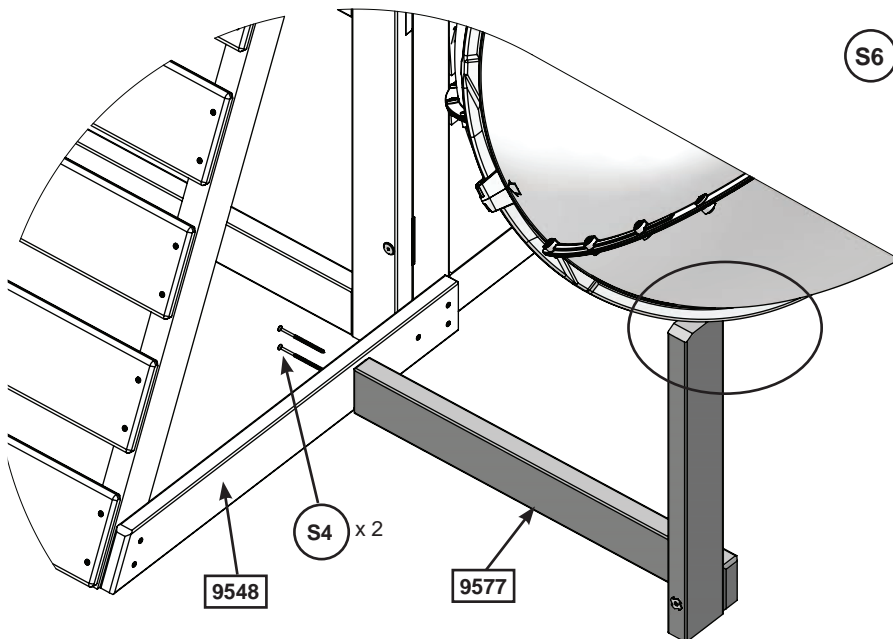

Fig. 46.1



Hardware

- 2 x (S6) #12 x 1" Pan Screw
- 2 x (S4) #8 x 3" Wood Screw
- 1 x (S37) #7 x 5/8" Pan Screw

Other Parts

- 2 x TNR4 Post Mount Clamp
- 1 x TNR 4 Post Mount Base
- 1 x 1/4 x 14.5 mm Pan Head Bolt
- 1 x Square Lock Nut

Step 47: Attach Ground Stake to TNR Upright



A: In the spot shown in fig. 47.1 drive 1 Rebar Ground Stake 13" into the ground against the (9577) TNR Ground Brace. Be careful not to hit the washer while hammering stake into the ground as this could cause the washer to break off.

B: Attach the ground stake to (9577) TNR Ground Brace just below the bolt head using 1 (S7) #12 x 2" Pan Screw as shown in fig. 47.1.

C: After driving stakes into the ground, check for sharp edges caused by the impact of the hammer. Smooth any sharp edges from impact area and touch up with outdoor paint.



Warning! To prevent tipping and avoid potential injury, stakes must be driven 13" (330mm) into ground. Digging or driving stakes can be dangerous if you do not check first for underground wiring, cables or gas lines.

Fig. 47.1

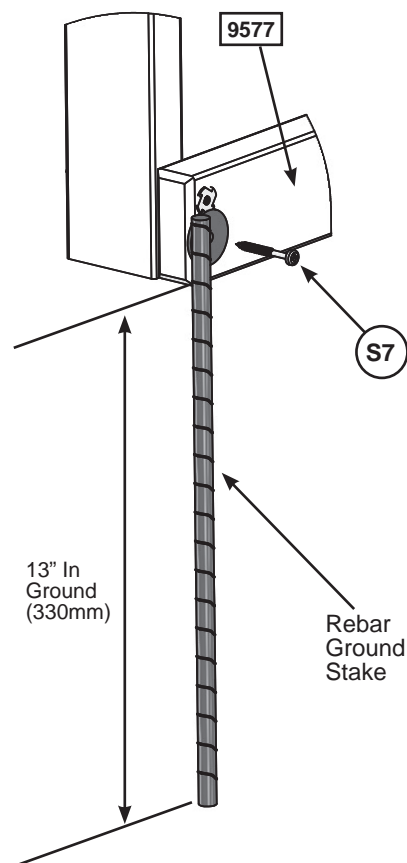

Hardware

1 x  #12 x 2" Pan Screw

Other Parts

1 x Rebar Ground Stake

Step 48: Attach Swings

A: Using 1 Threaded Quick Link per chain, join 1 Long Swing Chain to each side of the Swing Belt Seat. Make sure to close the Threaded Quick Link tightly using an adjustable wrench. (fig. 48.1 and 48.2).

B: Using 1 Threaded Quick Link per chain, join the Short Swing Chain to the Acro Bar and Acro Handle. Make sure to close the Threaded Quick Link tightly using an adjustable wrench. (fig. 48.2 and 48.3)

C: Attach the other end of the swing chains to the Spring Loaded Quick Links attached to the Heavy Duty Swing Hangers. (fig. 48.1)

Fig. 48.1

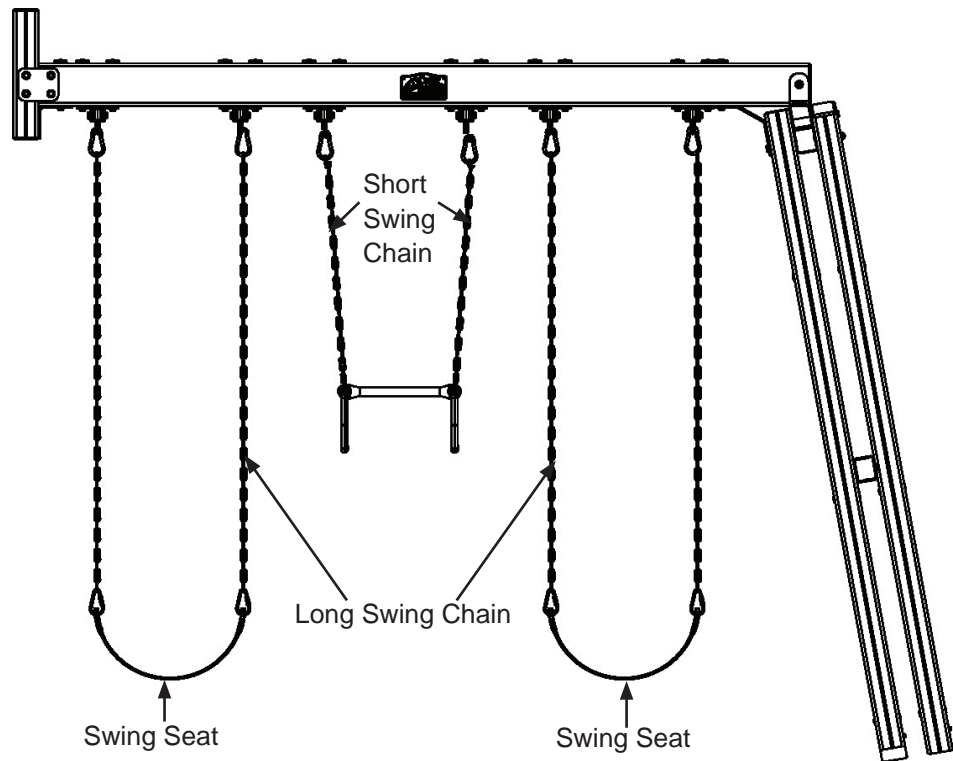

Caution: Threaded Quick Links must be installed with the gate completely down covering the threads and tighten as instructed. (fig.62.2)

Fig. 48.2



Threaded Quick Links attach to seat and Acro bar.



Tighten Threaded Quick Link using adjustable wrench

Fig. 48.3

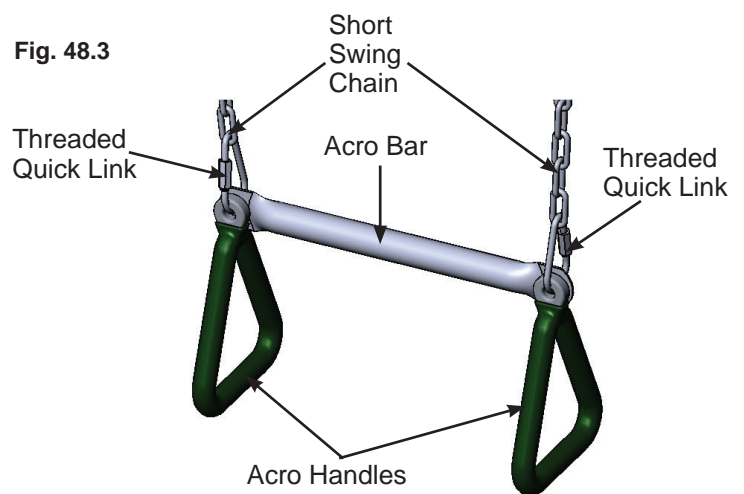

Other Parts

- 1 x Acro Bar
- 2 x Acro Handle
- 2 x Swing Belt Seat
- 2 x Short Swing Chain
- 4 x Long Swing Chain
- 6 x Threaded Quick Link

Step 49: Assemble and Attach BBQ Kitchen Part 1



A: On (9286) Front Wall place BBQ Base on (2611) Table Top. Use BBQ Cooktop as a guide so there is enough room for BBQ Cooktop and 1" gap to the edge of the wall to the left of BBQ Base. Attach BBQ Base to (2611) Table Top with 4 (S0) #8 x 7/8" Truss Screws. (fig.49.1 & 49.2 & 49.3 & 49.4)

B: Snap BBQ Lid on to the back of BBQ Base. (fig.49.2)

Fig. 49.1

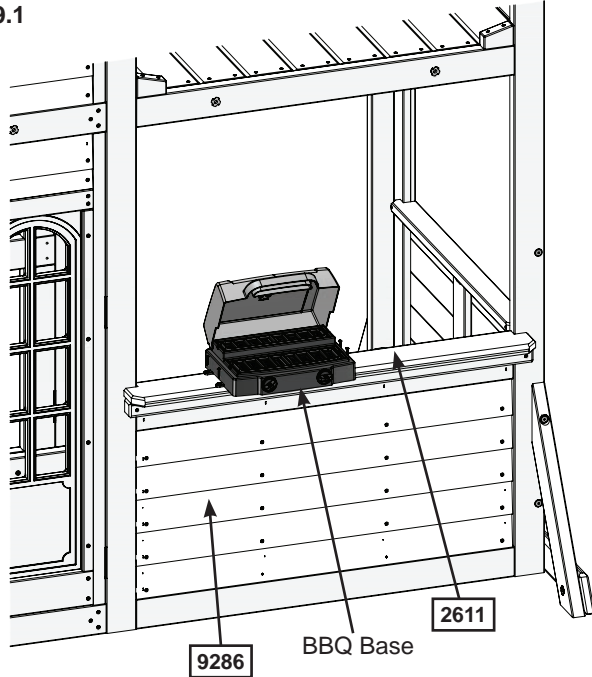

Fig. 49.2

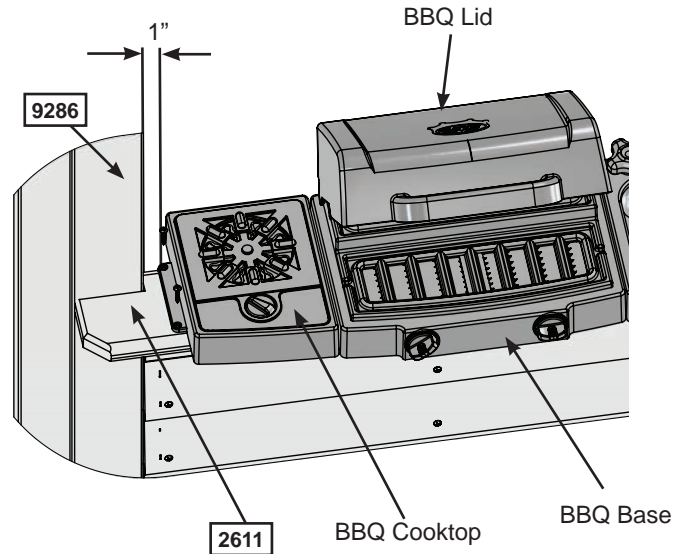

Fig. 49.3

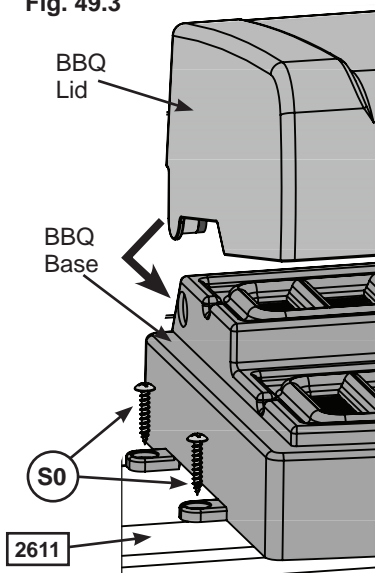
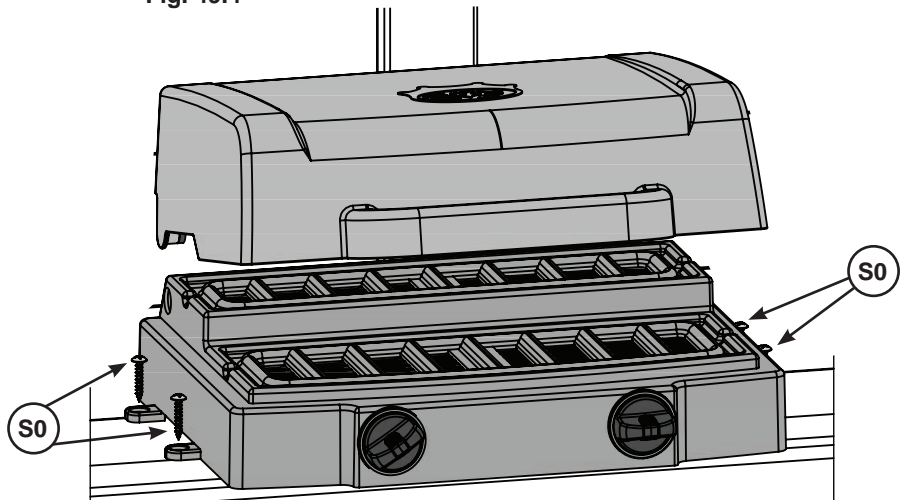

Fig. 49.4



Hardware

4 x (S0) #8 x 7/8" Truss Screw

Other Parts

1 x BBQ Base
1 x BBQ Lid

Step 49: Assemble and Attach BBQ Kitchen Part 2

C: Slide BBQ Cooktop tight beside BBQ Base on the left and BBQ Sink Set tight on the right. Attach both BBQ Cooktop and BBQ Sink Set to (2611) Tabel Top with 2 (S0) #8 x 7/8" Truss Screws each. (fig.49.5, 49.6, 49.7 and 49.8)

D: Place Faucet and 2 Sink Knobs in opening of Sink and attach Sink Knobs with included hardware. (fig. 49.9)
Important: Use a hand held screw driver and **DO NOT** over tighten.

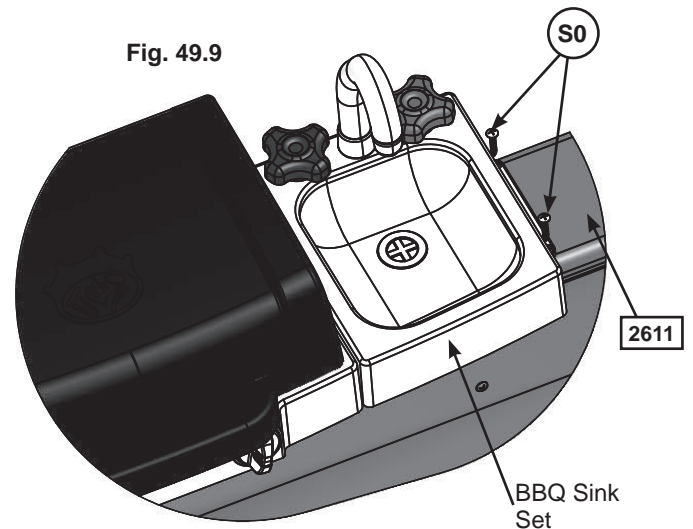
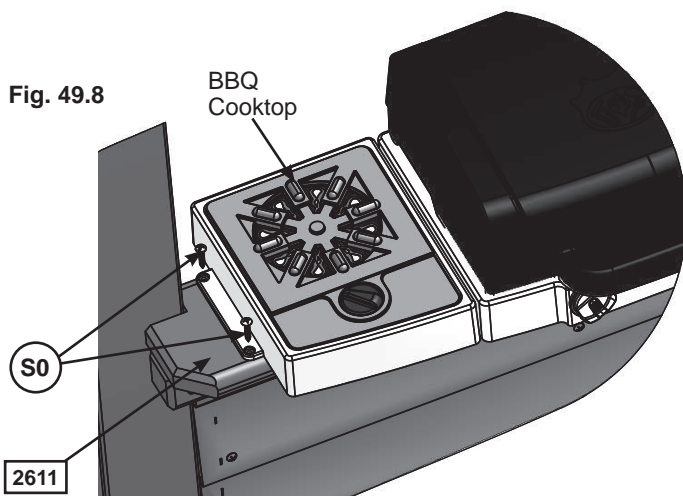
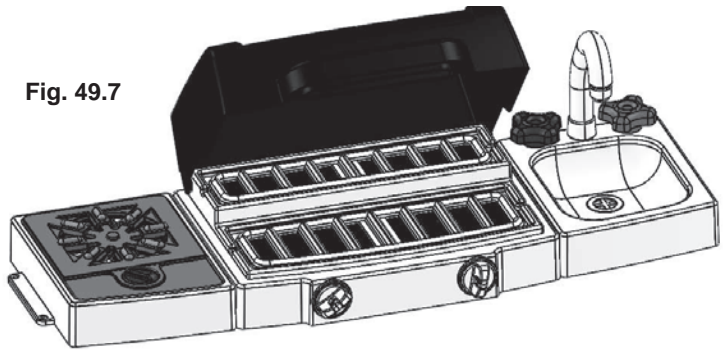
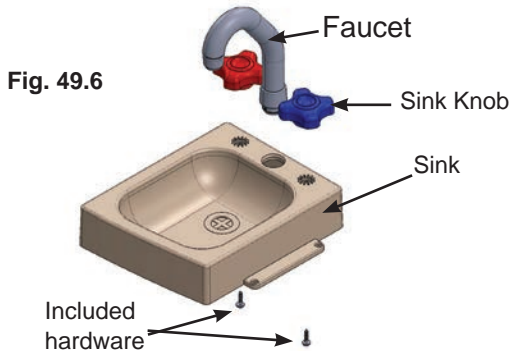
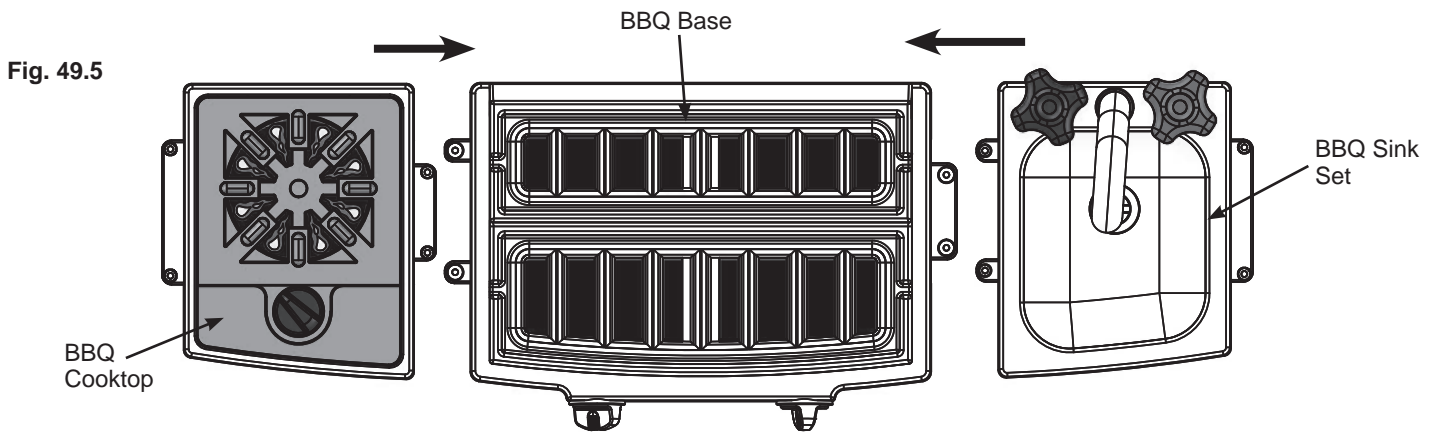

Hardware

4 x (S0) #8 x 7/8" Truss Screw

Other Parts

1 x BBQ Cooktop
 1 x BBQ Sink

Step 50: Attach Utensil Shelves Part 1

A: From outside the assembly in the top left side of the opening in (1986) Front Panel Assembly, 1" in from the panel, attach 1 Utensil Shelf with 2 (S0) #8 x 7/8" Truss Screws as shown in fig. 50.1 and 50.2.

B: Attach Sign to the Utensil Shelf.(Fig. 50.1)

C: Place Basket next to BBQ Kitchen on (9234) Table Top. (fig. 50.3)

Fig. 50.1

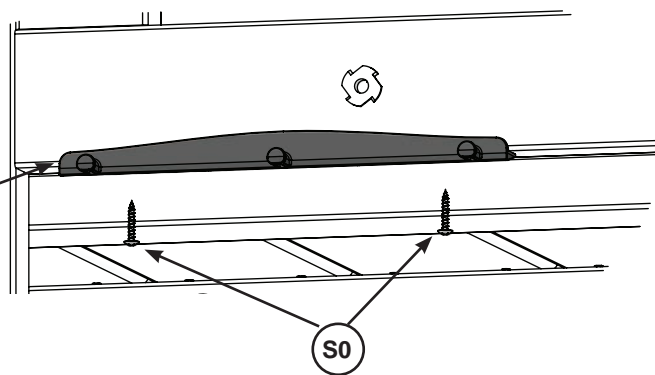

Fig. 50.2

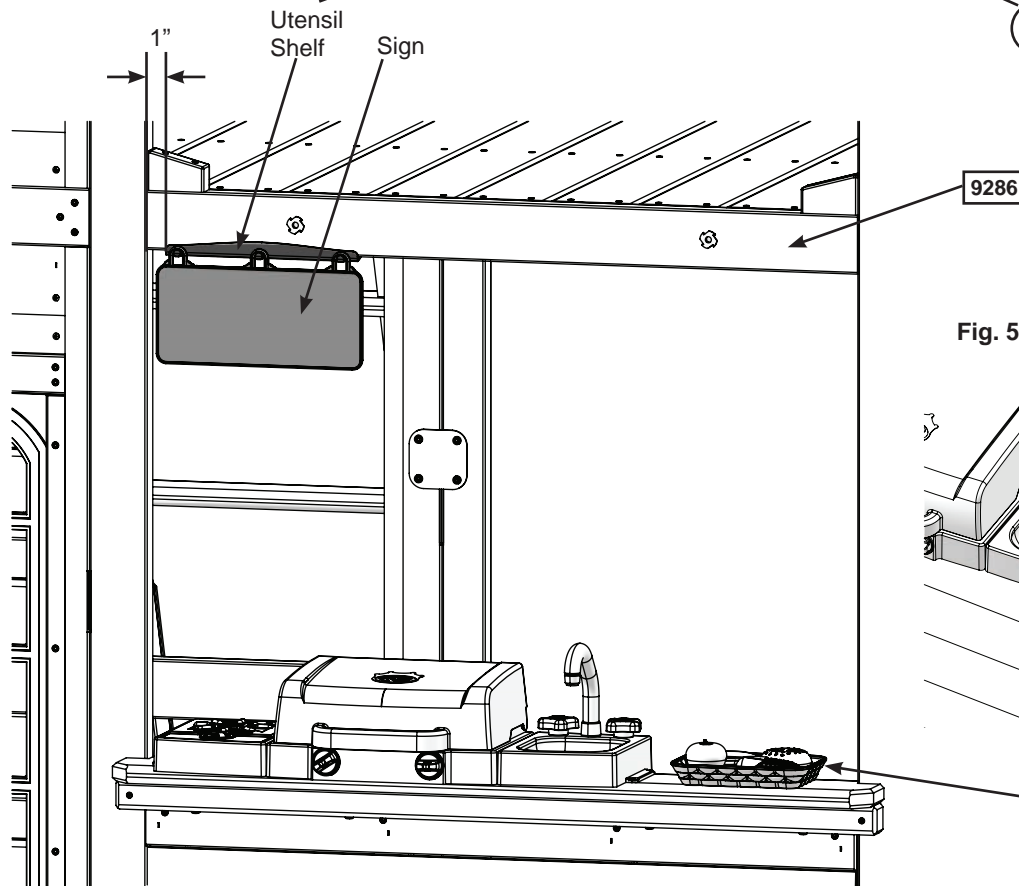
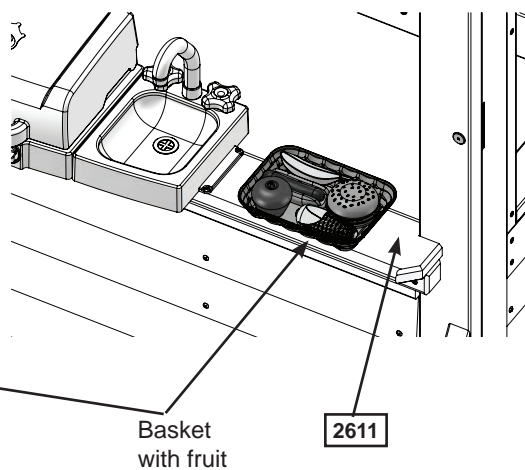

Fig. 50.3



Hardware

2 x (S0) #8 x 7/8" Truss Screw

Other Parts

1 x Utensil Shelf
1 x Sign
1 x Basket with fruit

Step 50: Attach Utensil Shelves Part 2

D: From outside the assembly, centred below the BBQ Kitchen attach 1 Utensil Shelf to (2611) Table Top with 2 (S0) #8 x 7/8" Truss Screws as shown in fig. 50.4 and 50.5.

E: Attach Pan, Tongs and Spatula to the Utensil Shelf. (fig. 50.6)

Fig. 50.4

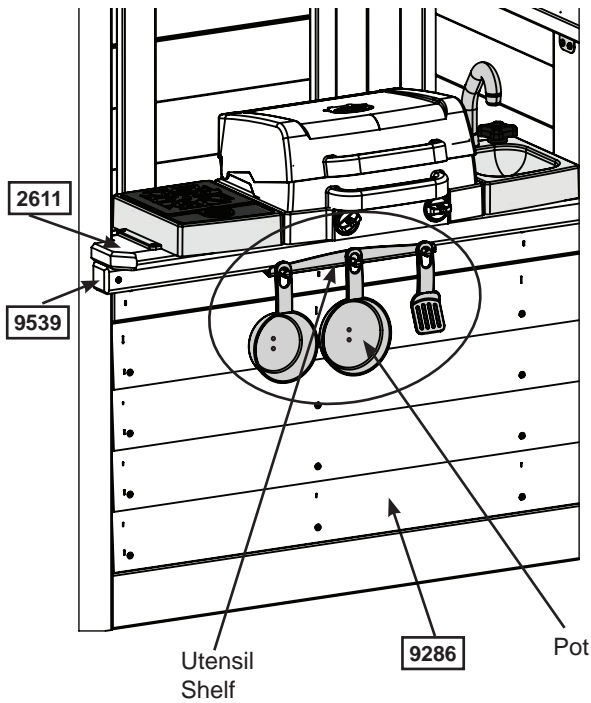

Fig. 50.5

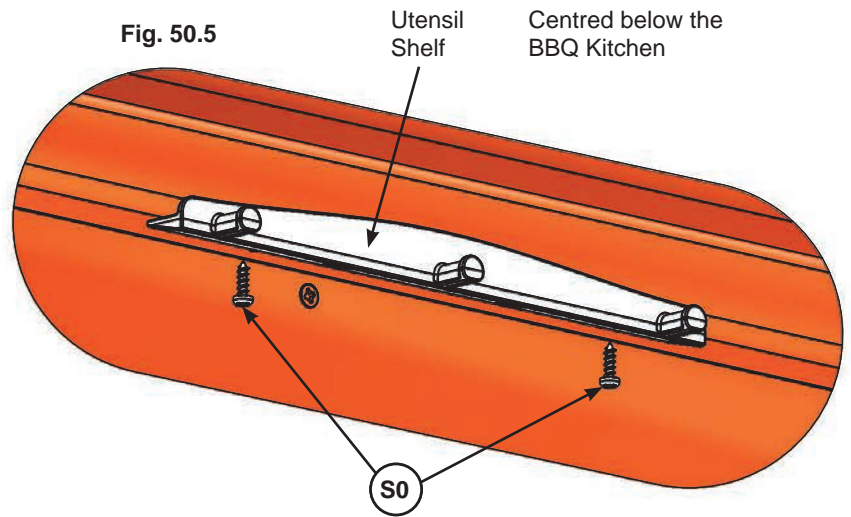
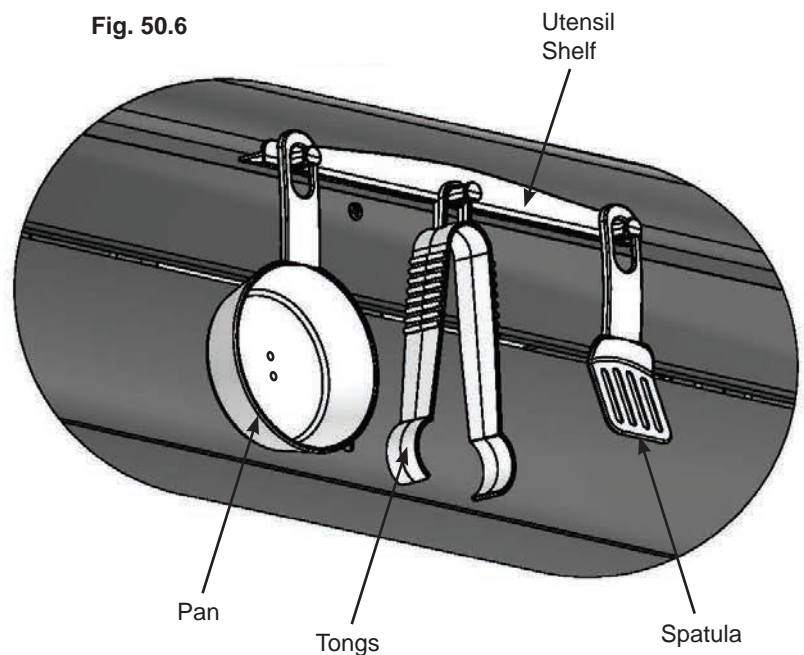

Fig. 50.6



Hardware

2 x (S0) #8 x 7/8" Truss Screw

Other Parts

1 x Utensil Shelf
1 x Pan
1 x Tongs
1 x Spatula
1 x Pot

Step 51: Attach Slides to Fort



Note: Pre-drill all holes using a 1/8" drill bit before installing the pan screws.

A: Place Slide Centered in the opening of the (9286) Front Wall Panel. (fig. 51.1)

B: Attach slide to fort using 4 (S7) #12 x 2" Pan Screws. (fig. 51.2)

Fig. 51.1

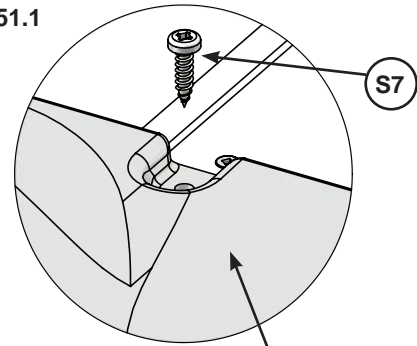
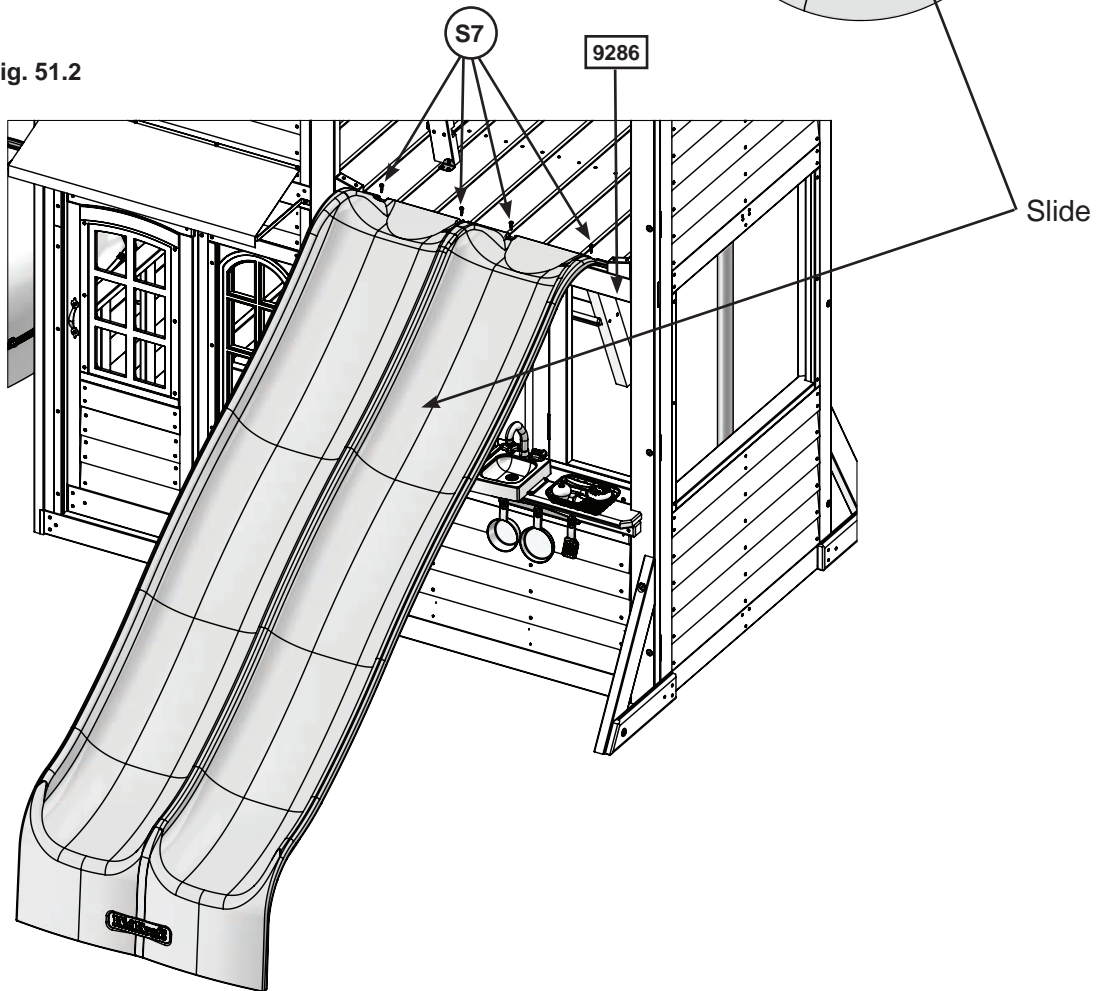



Fig. 51.2



Hardware

4 x  #12 x 2" Pan Screw

Other Parts

1 x Double Ride Maze
N Wave Slide

Step 52: Attach Pole

Part 1

A: Attach Fire Man Pole to (9580) Pipe Top using 3 (H9) 1/4 x 1- 1/4" Hex Bolts (with lock washer, flat washer and t-nut). (fig. 52.1)

Fig.52.1

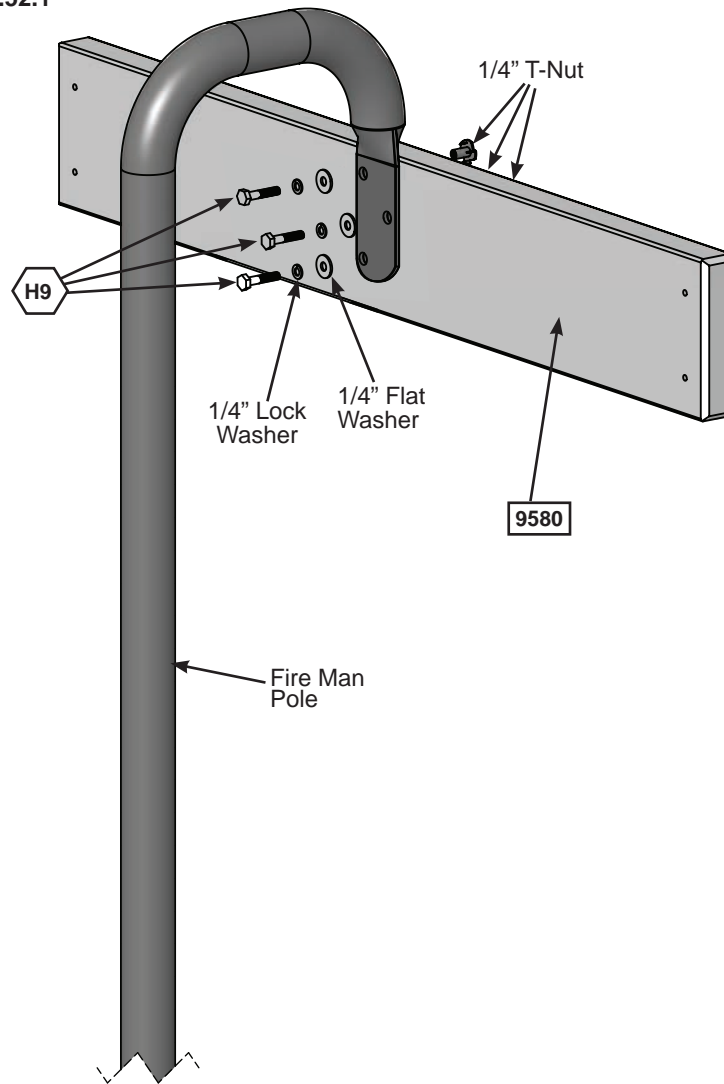

Wood Parts

1 x 9580 Pipe Top 1 1/4 x 5 1/4 x 33 5/16"

Hardware

3 x H9 1/4 x 1-1/4" Hex Bolt
(1/4" lock washer, 1/4" flat washer, 1/4" t-nut)

Other Parts

1 x Fire Man Pole

Step 52: Attach Pole Part 2



B: In the upper left side opening in the (9287) Back Panel Assembly, position (9580) Pipe Top against the frame from the outside, measuring to ensure that there is a 3-1/8" space between the top of the frame and the (9580) Pipe Top. Make sure the Fireman Pole is straight and that the bottom of the pole is inserted into the ground as needed (approximately 1-1/4"). Pre-drill using a 1/8" drill bit, then attach using 4 (WL5) Wafer Lags (with flat washer). (Fig. 52.2 & 52.3)

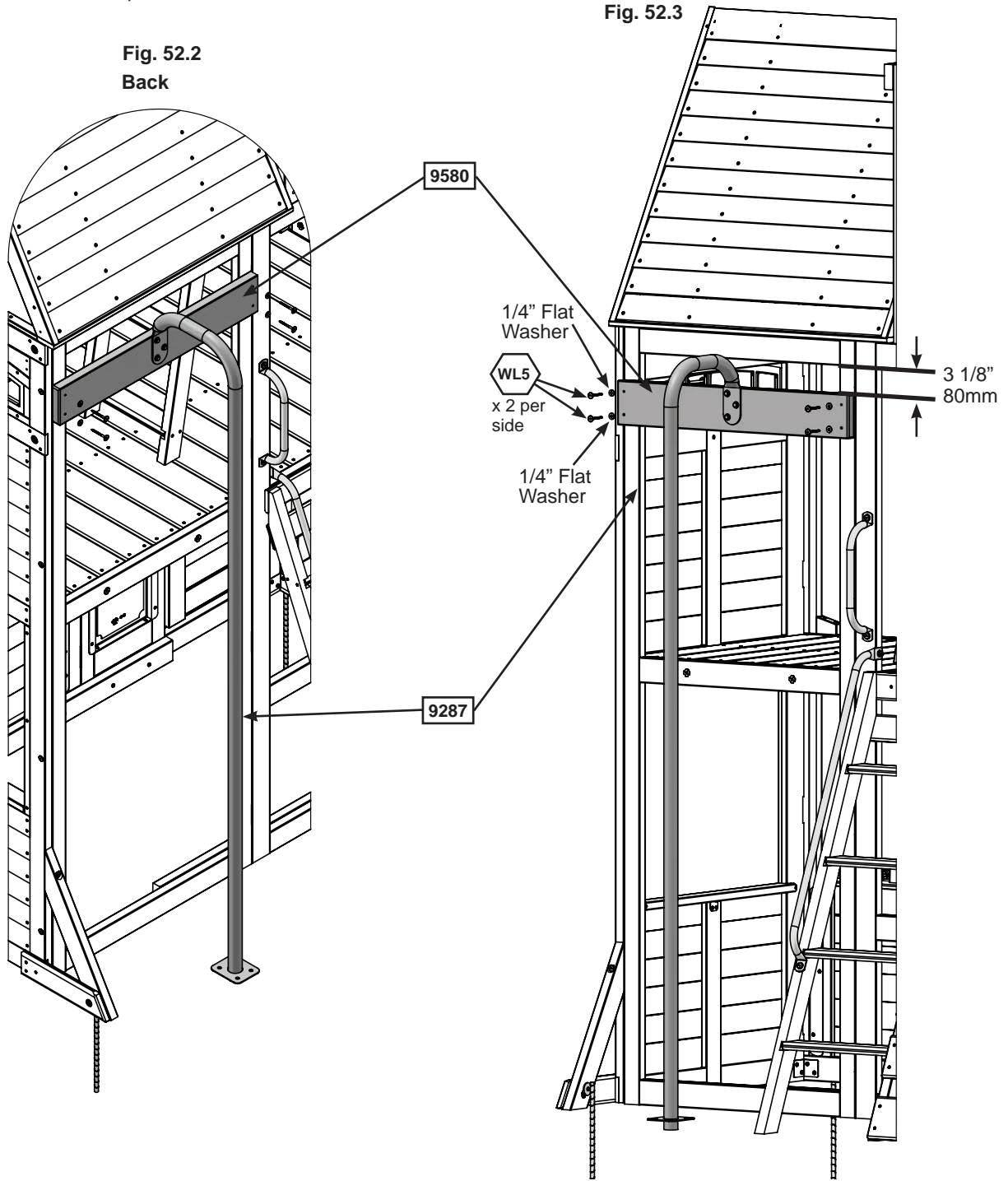

Hardware

4 x  1/4 x 2-1/2" Wafer Lag (1/4" flat washer)

Step 53: Attach U-Style Ground Stake to Pole

A: Check to ensure that the pole is approximately 1-1/4" into the ground and plate is lying flat. Hammer U-Style Ground Stakes into the holes in the plate until they are fully anchored into the ground. (Fig.53.1)

Fig. 53.1

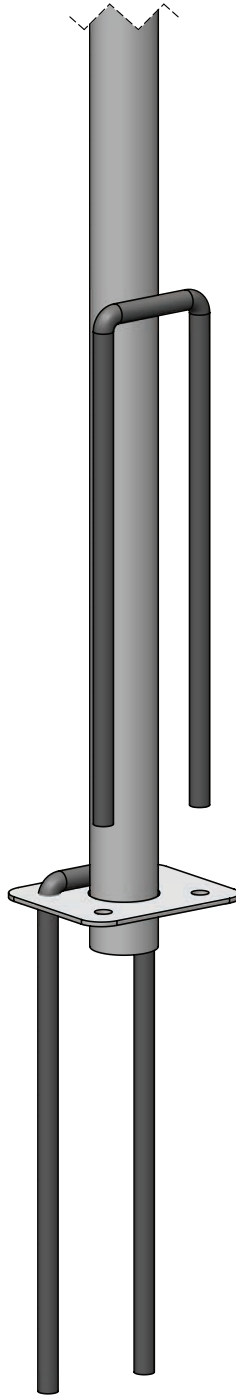

pole is to be 1-1/4" into
the ground when installed

Other Parts

2 x U-Style Ground Stake

Step 54: Attach Telescope

A: On the top left hand corner of the upper Fence, attach Telescope Base on an angle with 2 (S20) #8 x 1-3/8" Wood Screw. (fig. 54.1 & 54.2)

Fig. 54.1

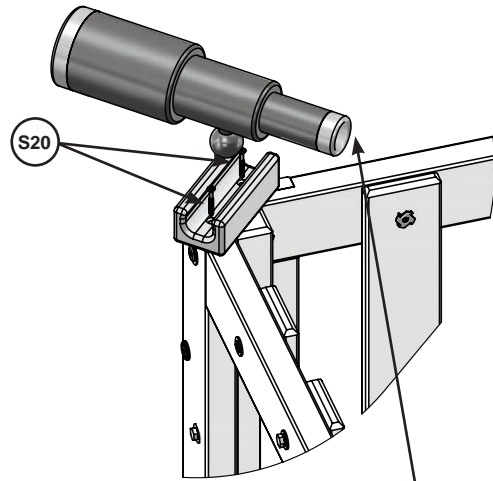

Telescope

Fig. 54.2

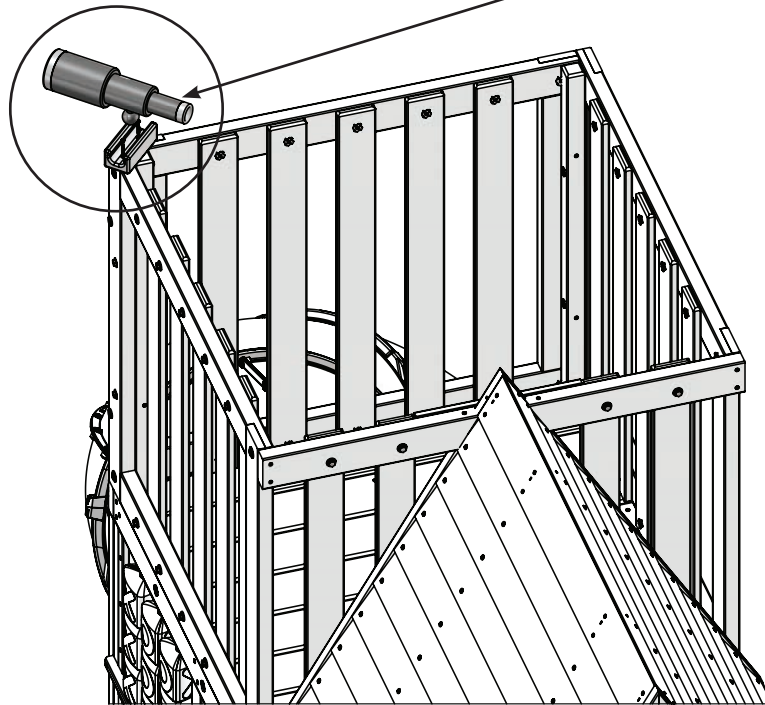

Hardware

2 x (S20) #8 x 1-3/8" Wood Screw

Other Parts

1 x Telescope

Step 55: Attach Canopy



A: Feed Cafe Canopy Frame through the pocket of the Cafe Canopy. (fig. 55.1)

B: With a helper hold the Canopy against the fort, centered over the door and window on (9286) Front Panel Assembly (fig. 55.1). Make sure the Cafe Canopy is smooth and tight then attach to the panel with 1 (S5) #8 x 1/2" Pan Screw (with #8 flat washer). Measure 1- 1/8" down from the first screw then attach a second screw and washer. Follow measurements as shown in (fig. 55.2) to install 2 more screws and washers on the opposite side, then install one more screw in the top center of the canopy. Measurements must be exact. (Fig. 55.1& 55.2 & 55.3)

C: Hold the Cafe Canopy Frame against the panel and attach with 1 (S5) #8 x 1/2" Pan Screw per side. (Fig.55.1 & 55.2)

Fig. 55.1

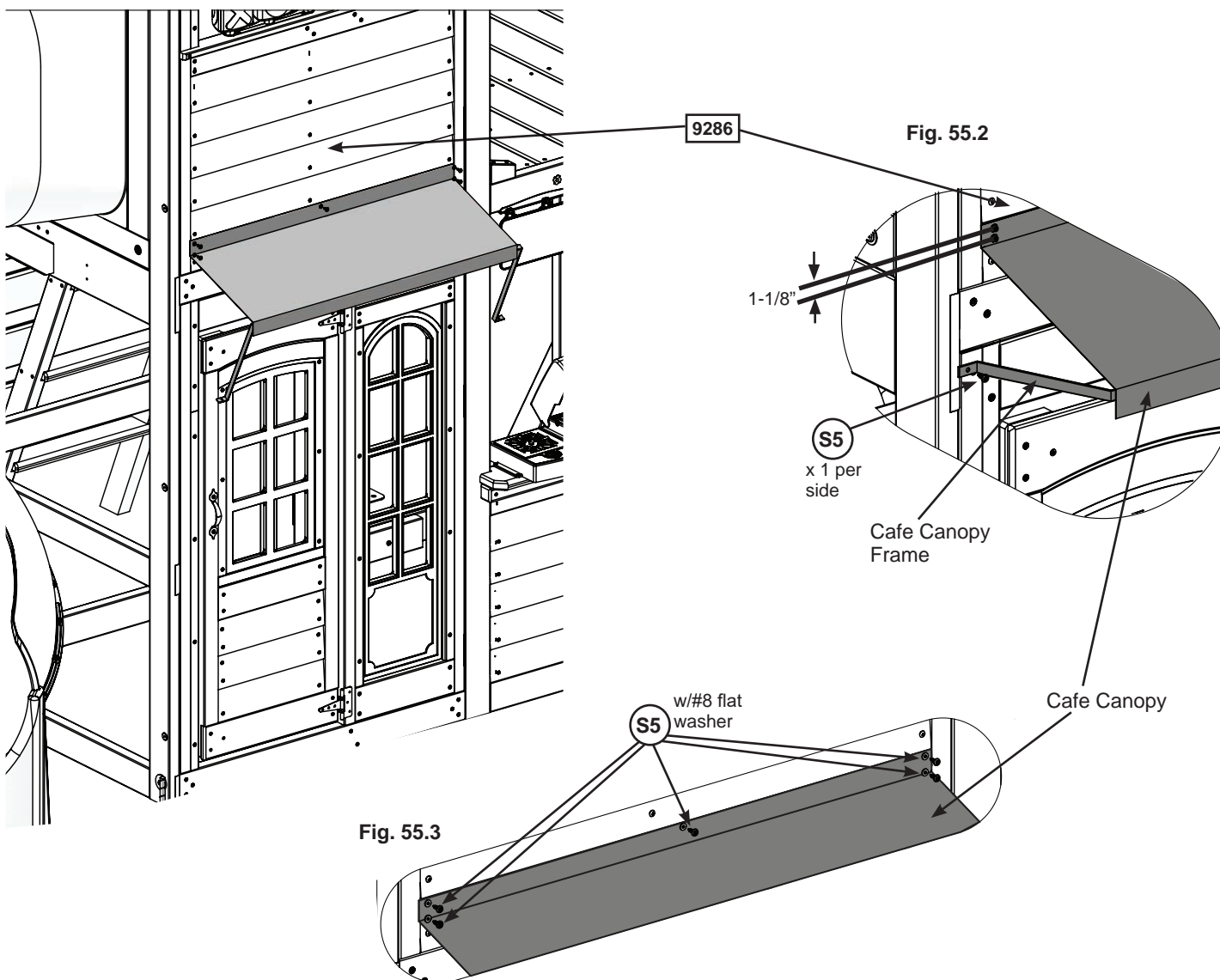

Hardware

- 5 x (S5) #8 x 1/2" Pan Screw (#8 flat washer)
- 2 x (S5) #8 x 1/2" Pan Screw

Other Parts

- 1 x Cafe Canopy Frame
- 1 x Cafe Canopy

Step 56: Attach Rocks

A: From behind the Rock Wall, place 1 Rock Back Block between the boards and hold in place. On the front of the wall, place 1 Rock over the Rock Back Block and install 2 (PB3) 1/4 x 1- 3/4" Pan Bolts (with lock washer, 3/16" flat washer and lock nut) through the Rock and the Rock Back Block as shown in figs. 56.1 and 56.2.

B: Repeat Step A to install 6 more Rocks.

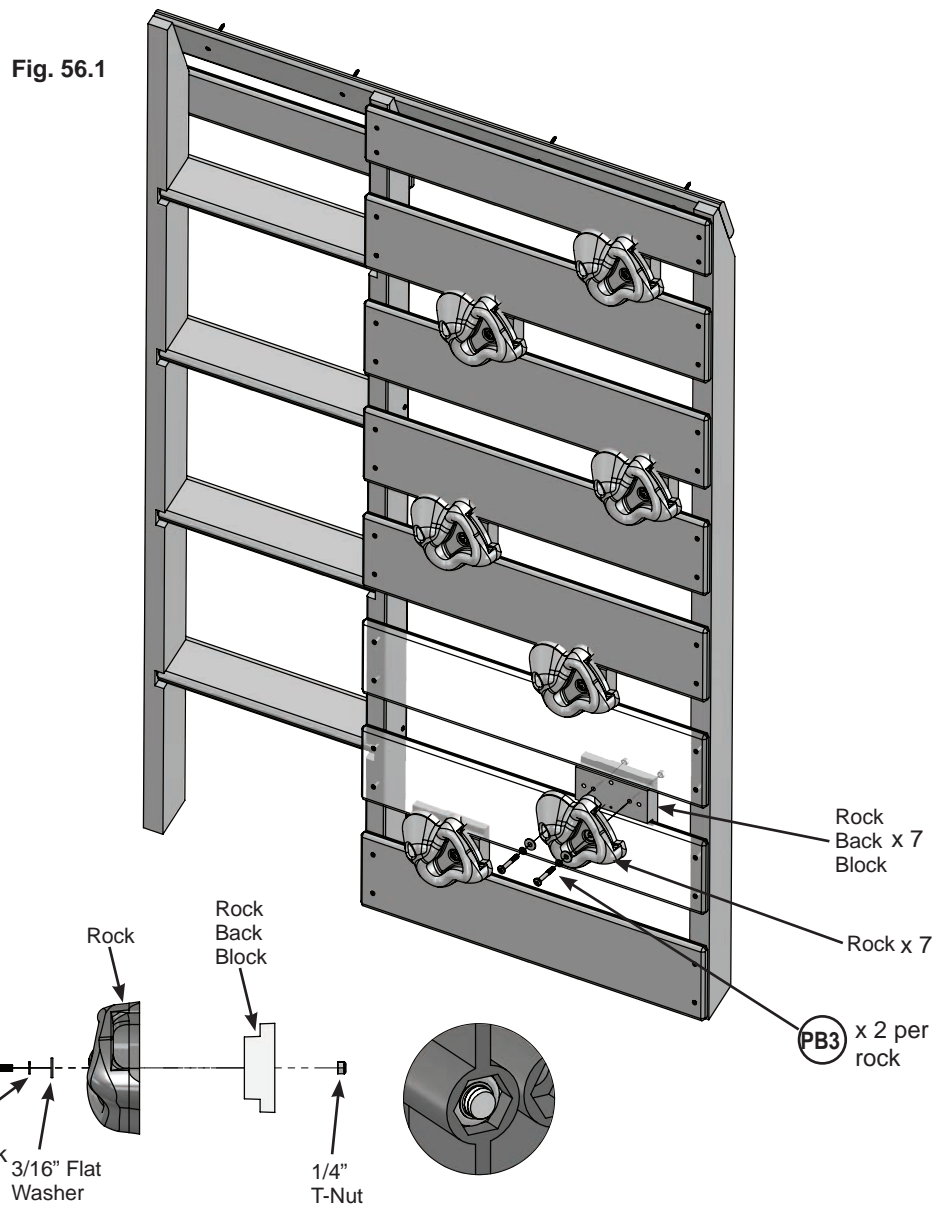

Hardware

14 x  1/4 x 1-3/4" Pan Bolt
(1/4" lock washer, 3/16" flat washer & 1/4" lock nut)

Other Parts

7 x Rock
7 x Rock Back Block

Final Step: Attach I.D. Plaque

ATTACH THIS WARNING & I.D. PLAQUE TO THIS LOCATION ON YOUR PLAY EQUIPMENT!

This provides warnings concerning safety and important contact information. A Tracking Number is provided to allow you to get critical information or order replacement parts for this specific model.

WARNING
AVERTISSEMENT

CONTINUOUS ADULT SUPERVISION REQUIRED!

STRANGULATION HAZARDS
Never allow children to play with ropes, clotheslines, pet leashes, cables, chains or cord-like items when using this playset or to attach these items to play-set.
Never allow children to wear loose fitting clothing, ponchos, hoods, scarves, capes, necklaces, or items with draw-strings, cords or ties when using this play-set.
Never allow children to wear bike or sport helmets when using this play-set.
 Failure to prohibit these items increases the risk of serious injury and death to children from entanglement and strangulation.

SERIOUS HEAD INJURY HAZARD
 Maintain shock absorbing material under and around play-set as recommended in the Installation & Operating Instructions. Installation over concrete, asphalt, dirt, grass, carpet and other hard surfaces creates a risk of serious injury or death from falls to the ground.

SURVEILLANCE CONSTANTE D'ADULTES REQUISE!

Risques d'étranglement
Ne jamais laisser les enfants jouer avec des cordes, cordes à linge, laisses pour animaux, des câbles, des chaînes ou ce type d'articles pendant l'utilisation de ce centre de jeu ou attacher un de ces éléments à la structure.
Ne jamais laissez les enfants porter des vêtements amples, des ponchos, des capuchons, des foulards, des capes, des colliers ou des articles avec cordons ou cordes libres pendant l'utilisation de ce centre de jeu.
Ne jamais laissez les enfants porter un casque de vélo ou de sport quand ils utilisent ce centre de jeu.
 Ne pas respecter ces consignes augmente le risque de blessures graves ou de décès des enfants par enchevêtrement ou étranglement.

RISQUE DE BLESSURES GRAVES À LA TÊTE
 Entretien le matériau d'absorption des chocs sous et autour de la structure de jeu tel que recommandé dans les instructions d'installation. L'installation sur du béton, de l'asphalte, le sol, l'herbe, le tapis et autres surfaces dures crée un risque de blessure à la tête grave ou mortelle en cas de chute.

THIS PRODUCT IS INTENDED FOR USE BY CHILDREN FROM AGES 3 TO 10; weight limit of 110 lbs. per child. Maximum number of users. Installation & Operating Instructions; other information is available at:
 POUR LES ENFANTS DE 3 À 10 ANS D'ÂGE: limite de 110 Livres par enfant. Nombre maximum d'utilisateurs, installation et d'utilisation; d'autres informations sont disponibles sur:

www.KidKraft.com
 Contact us at: KidKraft
 Dallas, TX 75244 USA
 1-800-933-0771

Tracking Number:
 Numéro de Suivi:

A: Attach KK Playset Plaque to a location on your set that is easily seen and read by a supervising adult using 4 (S37) #7 x 5/8" Pan Screws as shown below.

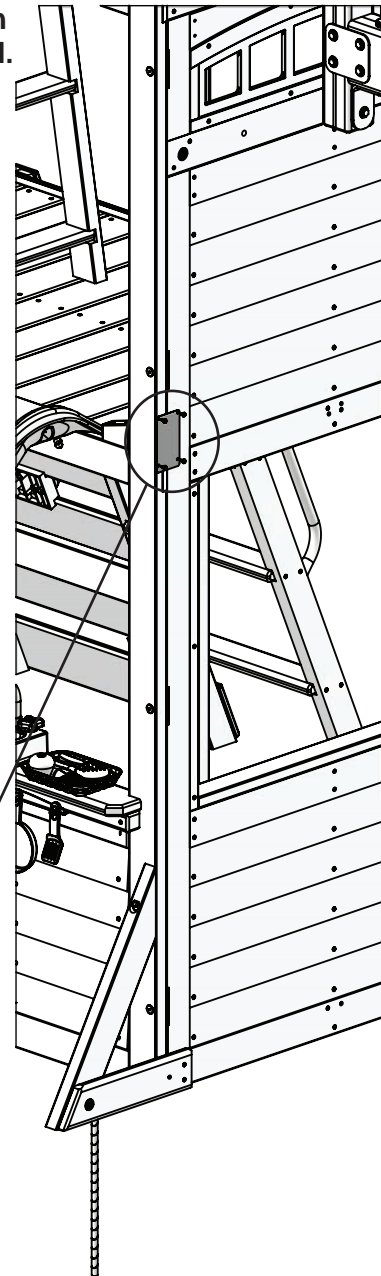
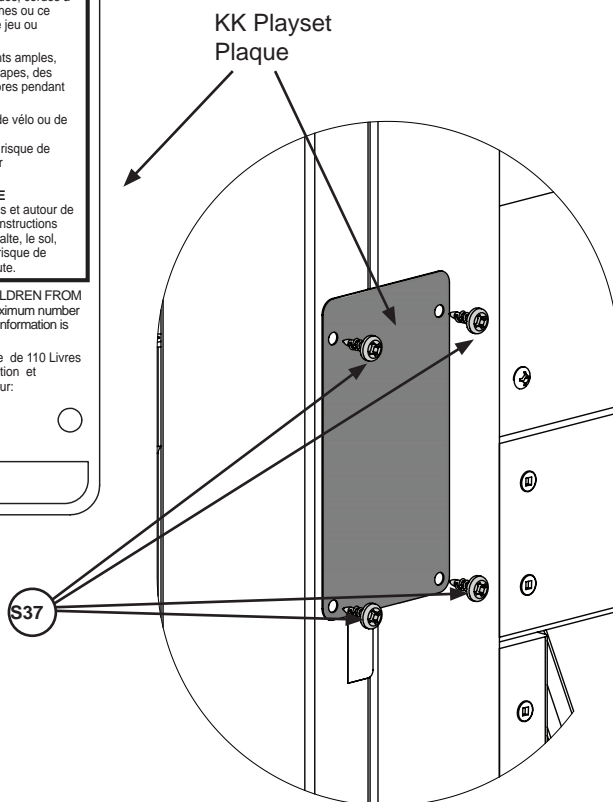

Hardware

4 x **(S37)** #7 x 5/8" Pan Screw

Other Parts

1 x KK Playset Plaque

CEDAR SUMMIT
Consumer Registration Card

First Name Initial Last Name

--	--	--

Street Apt. No.

--	--

City State/Province ZIP/Postal Code

--	--	--

Country Telephone Number

--	--

E-Mail Address

--

Model Name Model Number (Box Labels)

--	--

Serial Number (on ID Plaque)

--

Date Purchase Purchased From

--	--

MM / DD / YY

How would you rate this product for quality?

Excellent Very Good Average Below Average Poor

How would you rate this product for ease of assembly?

Excellent Very Good Average Below Average Poor

How would you rate our instructions?

Excellent Very Good Average Below Average Poor

How would you rate the quality of packaging?

Excellent Very Good Average Below Average Poor

Would you recommend the purchase of our products to friends and family?

Yes No

Comments:

MAIL TO:
KidKraft
4630 Olin Road
Dallas, TX 75244
United States
Attention: Customer Service



Fill out your registration card online at
www.cedarsummitplay.com/registration

Cedar Summit by KidKraft would like to say
Thank You for your time and feedback.

