

STANLEY®

ELECTRIC PRESSURE WASHER 2200W 2175PSI



**MODEL NO.
SXEW217501**



For service, spare parts or product information,
please contact Smart Marketing Group Pty. Ltd.

AUST. 1300 660 457 N.Z. 0800 474 876

03649 10/21

SUGGESTED APPLICATIONS

These are some suggested articles which could be cleaned by this pressure washer:

- Concrete driveway
- Paved area
- Car
- Motorbike
- Truck
- Wall
- Garden feature

TECHNICAL INFORMATION

Specifications	
Pressure washer	SXEW217501
Maximum pressure	2175PSI
Rated pressure	1740PSI
Flow rate	7.5L/min
Water inlet pressure	1.0 MPa
Max. water temp	35°C
Power Input	2200 W
Noise	93db @ 7m
Mains voltage	240V AC
Mains frequency	50Hz

CONTENTS

Section	Page
Contents	2
Suggested Applications	2
Introduction	3
Guarantee	3 – 4
General Safety Instructions	5 – 7
Specific Safety Instructions	8
Fuel & Oil Information	9
Components and Controls	10
Assembly Instructions	11 – 12
Operating Instructions	13 – 17
Cleaning Tips	18
Maintenance	19 – 20
Trouble Shooting	21
Parts Diagram	22
Service Log	23
Technical Information	24
Contact Information	24

For any queries or assistance call



Customer Service

AUST. 1300 660 457
NZ 0800 474 876

Hours of operation:

Monday to Friday 8.00am - 5.00pm AEST

Do not return to place of purchase.

Keep your purchase receipt, this will be required to make any claims under the 24 month warranty.

Please take note of serial number and write here for ease of reference:

Serial Number: _____

Date of Purchase: _____

Place of Purchase: _____

Receipt Number: _____

INTRODUCTION

Dear Customer,

Thank you for purchasing this pressure washer which has passed through our extensive quality assurance processes. Every care has been taken to ensure that it reaches you in perfect condition. However, in the unlikely event that you should experience a problem, or if you require any assistance please do not hesitate to contact us;



If you have a problem, call customer service do not return this pressure washer to the place of purchase.

CUSTOMER SERVICE

Australia: 1300 660 457

New Zealand: 0800 474 876

Operating times: Monday – Friday

8.00am - 5.00 pm

Australian Eastern Standard Time (AEST)

EXPRESS WARRANTY STATEMENT PRESSURE WASHER

You are not required to do anything to register your pressure washer purchase. Please attach the purchase receipt to this manual and ensure both are kept safe. We hope you enjoy your new pressure washer, and if you have any problems call customer service on the above phone numbers. Do not return to place of purchase.

Smart Marketing Group Pty Ltd (SMG) warrants that this pressure washer will be free from manufacturing faults or defects for 24 months from the date of purchase, providing original purchase receipt is kept and shown when needed and is subject to the terms and conditions below.

If a warranty fault appears within the warranty period, SMG reserves the right to replace or repair the product. In the event that SMG chooses to replace the product, this original warranty will expire at the original date. If the product includes various accessories or components, only the defective accessory or component will be replaced or repaired.

SMG reserves the right to replace defective parts of the product with parts and components of similar quality, grade and composition where an identical part or component is not available.

Products presented for repair may be replaced by refurbished products of the same type rather than being repaired. Refurbished parts may be used to repair the products.

WHAT IS COVERED

- Manufacturing fault or defect.

HOW TO CLAIM UNDER THIS WARRANTY

- Call customer service.
- Ensure you have the following: Original purchase receipt, Model of pressure washer, Serial number of pressure washer.
- Discuss the issue.
- Customer service will advise which authorised service agent to take the pressure washer to provided the issue is a warranty one.
- Take pressure washer to authorised service agent for repair.

WHAT IS NOT COVERED

- Use of Pressure Washer for hire.
- Commercial use of pressure washer.
- Use of pressure washer in a commercial premises.
- Damage or deterioration due to transport.
- Damage caused by negligence, misuse, abuse or accident or incorrect voltage and wattage.
- Any corrosion or rusting.
- Damage caused by incorrect set up and start up.
- Replacement parts due to general wear and tear.
- Pressure washers with serial number defacement, modification or removal.
- Pressure washers which have been serviced by other than an authorised SMG service agent.
- Pressure washers with no original purchase receipt.
- Pressure washers which have been on sold, not original purchaser.
- Damage due non-servicing of pressure washer as is required by this manual.
- Blockages / damage caused by dust, dirt, spiders webs or insects.
- Damage caused by the incorrect fitting of accessories.
- Damage caused by overloading, overworking the pressure washer.
- Damage to attached equipment or third party accessories.
- Damage caused by attached equipment or third party accessories.

CONTACT DETAILS

Smart Marketing Group Pty Ltd
33-35 Lionel Road, Mt. Waverley
Victoria 3149, Australia.
Tel (+613) 9543 7266
Fax (+613) 9543 9839
sevice.group@smga.com.au

COMPLETE WARRANTY STATEMENT – PRESSURE WASHER

As soon as you have purchased the pressure washer, we recommend that you check to make sure it is intact and that you read the operating instructions carefully before using it. The purchase receipt for this product is to be retained and must be presented if making a claim under the terms of the Smart Marketing Group (SMG) warranty. Bank account statements are not acceptable for proof of purchase.

This warranty does not cover pressure washers intended for hire or use in commercial applications or in commercial premises. The warranty will under no circumstances extend to reimbursement or payment of damages, whether direct, indirect or consequential. The warranty is void if there is evidence the pressure washers has been modified or tampered with in any way or used with unauthorised accessories without our consent.

SMG declines any responsibility or liability whatsoever arising from misuse or abuse, negligent handling of the pressure washers or if the product has not been installed or failure to comply with the relevant safety, operating, setting and maintenance instructions (see further in this manual).

The warranty does not extend to installation or disconnection costs.

Any item sent freight forward/collect for repair will be refused. Warranty repairs are free of charge, provided the appliance is delivered to our service department or authorised service agent. The pressure washer will need to be returned, adequately protected in a box. SMG will not be responsible for any in-transit loss or damage. Assistance under the warranty will only be made available if the request is made to our customer service team on the contact numbers listed below and proof of purchase is provided.

This is a repair only warranty you will need to take the pressure washer to the authorised service agent after contacting our customer service centre.

If the product includes various accessories or components, only the defective accessory or component will be replaced or repaired.

SMG reserves the right to replace defective parts of the product with parts and components of similar quality, grade and composition where an identical part or component is not available.

Products presented for repair may be replaced by refurbished products of the same type rather than being repaired. Refurbished parts may be used to repair the products.

Damage caused by third party accessories is not covered under this warranty.

Damage caused to attached equipment or third party

accessories will not be covered under this warranty.

Rust and corrosion are not covered under this warranty.

If a warranty fault is found the freight cost will be credited to the owner. If no fault is found the product will be returned and any costs associated with the service will be charged to the owner.

Blockages caused by spider webs, insects, dirt, accumulated dust, incorrect voltage and wattage are not covered by warranty. SMG reserves the right to replace or repair the appliance within the warranty period. Parts found to be defective due to a manufacturing default will be replaced free of charge.

In the event of SMG choosing to replace the appliance, the warranty will expire at the original date of purchase. If no warranty fault is found the owner will be advised and the product will be returned and any costs associated with the service will be charged to the owner.

Our goods come with guarantees that cannot be excluded under the Australian Consumer Law. You are entitled to a replacement or refund for a major failure and for compensation for any other reasonably foreseeable loss or damage. You are also entitled to have the goods repaired or replaced if the goods fail to be of acceptable quality and the failure does not amount to a major failure. The benefits of this warranty are in addition to any rights and remedies imposed by Australian State and Federal legislation that cannot be excluded.

In New Zealand, this SMG warranty is in addition to the conditions and guarantees which are mandatory as implied by the New Zealand Consumer Guarantee Act 1993. For service, spare parts or product information please contact customer service:

Australia: 1300 660 457
New Zealand: 0800 474 876

CONTACT DETAILS

Smart Marketing Group Pty Ltd
33-35 Lionel Road, Mt. Waverley
Victoria 3149, Australia.
Tel (+613) 9543 7266
Fax (+613) 9543 9839
service.group@smga.com.au

GENERAL SAFETY INSTRUCTIONS

ASSEMBLY

This pressure washer **MUST** be fully assembled by you prior to use. Failure to do so will result in the warranty being **VOID**. Failure to fully assemble this pressure washer may also result in personal injury.

SAFETY

Before attempting to operate this pressure washer the following basic safety precautions should be taken to reduce the risk of fire, electric shock and personal injury. It is important to read the instruction manual and to understand applications, limitations and potential hazards associated with this pressure washer. It is important that you read, understand and follow these instructions very carefully. This pressure washer is not intended for use by persons (including children) with reduced physical, sensory or mental capabilities, or lack of experience and knowledge, unless they have been given supervision or instruction concerning the use of the appliance by a person responsible for their safety.

BEWARE OF CHILDREN & PETS

Children and pets should be kept out of the operating area. Children should not be allowed to touch or operate pressure washers. All pressure washers should be kept out of reach of children. When **NOT** in use keep the pressure washer preferably stored or locked in a secure well ventilated cabinet or room.

WORK AREA

Work areas and benches should be kept tidy. Cluttered benches and work areas can cause accidents. Floors should be kept clean and free from rubbish. Special care should be taken when the floor is slippery due to sawdust or wax. Always leave sufficient distance, at least 5 metres between the pressure washer and the work area.

OPERATING ENVIRONMENT

ALWAYS use your pressure washer in an open well ventilated area. Do not expose your pressure washer to rain. Do not expose your pressure washer to direct sunlight. Keep the work area well lit. Do not use your pressure washer in areas where there is a risk of explosion or fire from combustible materials, flammable liquids, paint, varnish, petrol, etc flammable gases and dust of an explosive nature. As a precaution it is recommended that you consult an expert on selecting and using a suitable fire extinguisher and have it available for use in an emergency when operating the pressure washer.

SELECT A PRESSURE WASHER WITH A SUFFICIENT RATING

Select the right pressure washer for the job. Do not use a pressure washer to do a job for which it was not designed. Do not force a small pressure washer to do the job of a heavy duty pressure washer. Any damage caused by overloading will void the warranty. Do not use pressure washers for purposes not intended.

HOT COMPONENTS

Beware many of the components will get hot during use. Never touch any of the metal pipes, pump or motor as these may burn.

GUARD AGAINST ELECTRIC SHOCK

Avoid body contact with earthed or grounded surfaces (e.g. pipes and refrigerators).

DO NOT ABUSE THE POWER CORD

Never yank or pull on the power cord to disconnect it from the mains supply socket. Never carry or pull your pressure washer by its power cord. Keep the power cord away from heat, oil, solvents and sharp edges. Regularly check the plug and cord and if damaged stop using the pressure washer immediately and have it replaced by an authorised service facility.

EXTENSION CORDS AND REELS

Use of an extension cord with this product is **NOT RECOMMENDED**. If you must use an extension cord, use only extension cords that are intended for outdoor use. These cords are identified by a marking "ACCEPTABLE FOR USE WITH OUTDOOR APPLIANCES, STORE INDOORS WHILE NOT IN USE." Use only extension cords having an electrical rating not less than the rating of the product. Examine extension cord before use. **DO NOT USE DAMAGED EXTENSION CORDS!** If damaged never use always replace.

Always disconnect the extension cord from the power point before disconnecting the product from the extension cord.

WARNING – To reduce the risk of electrocution, keep all connections dry and off the ground. Do not touch the plug with wet hands.

- Do not use the appliance if a supply cord or important parts of the appliance are damaged, e.g. safety devices, high pressure hoses, trigger gun.
- If an extension cord is used, the plug and socket must be of watertight construction.
- **WARNING:** Inadequate extension cords can be dangerous
- Remove the plug from the socket-outlet during cleaning or maintenance and when replacing arts or converting the machine to another function.

GENERAL SAFETY INSTRUCTIONS

MAINTAIN YOUR PRESSURE WASHER WITH CARE

When not using your pressure washer ensure the ON/OFF switch is 'OFF'. Never leave the ON/OFF switch 'ON' as this can damage the pressure washer, and is also a danger if it is started with the switch 'ON' and the power cord is plugged in. Follow the instructions for lubricating and changing accessories. Keep handles clean, dry and free from oil and grease. Ensure that ventilation slots are kept clean and free from dust at all times. Blocked ventilation slots can cause overheating and damage to the motor.

STOP PRESSURE WASHER

Ensure that the pressure washer has stopped and is turned off when not in use, before servicing, lubricating, making adjustments or when changing any accessories.

DISCONNECT PRESSURE WASHER

Ensure that the pressure washer is disconnected from the mains supply when not in use, before servicing, making adjustments or when changing any accessories.

AVOID UNINTENTIONAL STARTING

Ensure that the switch is in the 'OFF' position before plugging the pressure washer into the mains supply.

REMOVE ADJUSTING KEYS AND WRENCHES

Form the habit of always checking to see that any adjusting keys or wrenches have been removed from the pressure washer before operating.

FIRE PRECAUTIONS

Always contact your fire authority before using the pressure washer on fire restricted days. It is not recommended to use your pressure washer when a total fire ban is in force. As a precaution it is recommended that an expert is consulted on obtaining and using a suitable fire extinguisher.

CLEANING YOUR PRESSURE WASHER

Always stop your pressure washer before you commence cleaning. Always ensure that your pressure washer has cooled, about one (1) hour, before cleaning and storing. When cleaning your pressure washer use only a damp soft cloth. NEVER use liquid or solvents of any type.

RISK OF DAMAGE

Damage may occur if nozzle is used too close to appliance being cleaned. Always trial test the pressure washer on an inconspicuous part of the appliance. Beware poor paint and rust as the water will lift poor paint and cause rust spots to grow. Damage caused by pressure washer is not covered by warranty.

CHECK DAMAGED PARTS

Before using the pressure washer it should be carefully checked to determine that it will operate properly and perform its intended function.

Check for broken or missing parts and have them replaced or repaired at an authorised service facility. Check any other condition that may affect the operation of the pressure washer. A guard or any other part of the pressure washer that is damaged should be properly repaired or replaced by an authorised service facility unless otherwise indicated in this instruction manual.

Any switch that does not operate correctly must be replaced by an authorised service facility.

DO NOT use the pressure washer if the 'ON / OFF' motor switch does not turn the pressure washer 'ON' and 'OFF'.



FOR YOUR SAFETY

This pressure washer is to be connected directly to an outdoor power point.

The electrical system of this pressure washer must be connected with an automatic 30mA circuit breaker and/or residual current device (RCD). If uncertain have a qualified electrician check your electrical system before use.

All electrical connections are made in a dry area.

Outdoor power points must be weatherproof and installed by a qualified electrician.

PERSONAL SAFETY INSTRUCTIONS

CLOTHING

Do not wear loose clothing, jewellery or anything that could get caught in moving machinery.

HAIR

Long hair should be tied back or contained in a protective covering.

EYE PROTECTION

The use of safety goggles is highly recommended (normal glasses are not sufficient for eye protection) when using pressure washers. Prescription glasses do not have safety lenses.

FOOTWEAR

Where there is the risk of heavy objects or if there is a risk of slipping on wet or slippery floors, suitable non-slip safety footwear should be worn. Protect your feet from dropping accidents.

EAR PROTECTION

The use of ear protection is highly recommended when using pressure washers. The continual noise may damage your ears.

RESPIRATORY PROTECTION

When cleaning dirt, concrete, man-made fibres, especially MDF (Medium Density Fibre board), the resin used in these materials can be hazardous to your health. Use an approved face mask with replaceable filter.

DO NOT OVER REACH

Do not over reach. Keep a proper footing and maintain your balance at all times. Avoid using abnormal stances and awkward body positions.

STAY ALERT

Watch what you are doing, use common sense, and never operate a pressure washer when you are tired, drinking alcohol, taking drugs or if taking medication that causes drowsiness.



WARNING

Only use pressure washer when fully assembled

Do not attempt to modify the pressure washer in any way; this will VOID your warranty.

The use of any attachment or accessory other than those recommended in this instruction manual could result in damage to the pressure washer and could cause injuries to the operator.

This pressure washer complies with Australian / New Zealand and International standards and safety requirements.

Repairs should only be carried out by qualified persons using original spare parts. Failure to do so may result in considerable danger to the operator.

SPECIFIC SAFETY INSTRUCTIONS

Warning! Do not use the pressure washer in areas where there is a risk of explosion or fire from combustible materials. The sparks possibly caused when using this pressure washer may ignite combustible materials as well as flammable liquids, paint, varnish, petrol, flammable gases and dust of an explosive nature. As a precaution it is recommended that you consult an expert on a suitable fire extinguisher and its use. Ensure that the work area is kept clear of combustible materials.

Warning! Do not use the pressure washer indoors or in confined spaces.

- Fully assemble pressure washer before use.
- Ensure the pressure cleaner is 'OFF' before plugging into the mains power supply.
- Always use the pressure washer in an open well ventilated area.
- Unit will become hot during use. Please keep pressure washer at least one metre (1m) away from buildings, other equipment, pedestrian areas or flammable materials.
- Ensure the pressure washer has stopped before servicing, or changing accessories.
- Do not attempt to modify the pressure washer, guards or the supplied accessories in any way.
- Never operate or store the pressure washer on its side, ALWAYS operate or store in an upright manner on firm, solid ground.
- Ensure that the pressure washer has stopped and turned off when not in use, before servicing, lubricating, making changes and when changing accessories.
- Your pressure washer is factory set, NEVER attempt to speed it up as this could endanger the user and damage the pressure washer and/or attached accessories.
- If the pressure washer makes an unfamiliar sound or vibrates excessively, switch the pressure washer 'OFF' immediately. Investigate the possible cause or consult your authorised service agent.
- Never use coolant in the pressure washer as damage may occur.
- Do not tamper or alter any parts as this may cause personal injury or damage the pressure washer.
- Never point gun/lance at people or animals.
- Never hose or wet people or animals.
- Never spray the pressure cleaner.
- Never spray electrical connections, electrical outlets or electrical appliances/fixtures.
- Never operate the pressure cleaner without water, any damage caused will not be covered by warranty.
- Never use hot water.
- Maximum water temperature is 35°C.
- Only use cold water with this pressure cleaner.
- Bystanders or people watching must be at least 10m away from operating the pressure cleaner.
- Only use clean water with this pressure cleaner.
- Never pump acids, alkaline, solvents or flammable liquids through this pressure cleaner, any damage caused will not be covered under warranty.
- Inlet water hose size must be at least 12mm diameter.
- Inlet flow rate must be at least 18 L/min and mains pressure.
- Damage may occur if pressure washer nozzle is held too close to the cleaning surface. Damage caused will not be covered under warranty.
- Always trial the pressure washer cleaner and selected nozzle on an inconspicuous part of the product to be cleaned.
- Ensure that the pressure cleaner is disconnected from the mains supply when not in use, before making changes or cleaning.
- Always carry your pressure cleaner by its handle.
- Only use Bio-Degradable detergent, with a PH level 6 – 8.
- NEVER use hot, dirty or chemically infested water as it will damage your pressure cleaner. Only use cold clean water
- Do not start the pressure cleaner with the water trigger 'ON'.
- Never use a pressure cleaner when standing on a ladder. If additional height is required a stable platform or approved scaffold must be used.
- Never clamp your pressure cleaner to a bench or other device, IT IS A HAND HELD TOOL.



ELECTRICAL DATA IMPORTANT

This pressure washer is fitted with a sealed electrical connection plug that is compatible with the mains power supply for Australia / New Zealand and meets the requirements of Australian Standards. This air compressor must be connected to a supply voltage that is equal to that stated on the rating label. If the mains power connection plug or power cord becomes damaged you must stop using the pressure washer immediately and it must be replaced with a complete assembly that is identical to the original, and this must be replaced by an authorised service centre. Always follow the Australian / New Zealand requirements for connection to the mains supply. If in doubt always consult a qualified electrician.

PIC. 1



- 1. Variable detergent control
- 2. On / Off Switch
- 3. Power cord holder
- 4. Gun with trigger
- 5. High pressure hose
- 6. Gun Holder
- 7. Handle
- 8. Lance
- 9. Hose reel handle
- 10. Adjustable nozzle
- 11. Wheel
- 12. Lance Support

UNPACKING & ASSEMBLY

UNPACKING

Note: Carefully unpack your pressure washer. Dispose of all packing material in an environmentally responsible manner.

Open carton, gently lift the pressure washer clear of the carton and packaging. Remove from plastic bag.

Note: Plastic bags can be a danger to young children, dispose of immediately. Always dispose of packaging in a responsible manner.

Your Pressure Washer needs minor assembly before use

CONNECTING LANCE TO GUN (PIC. 2)

- Push the lance into the gun firmly.
- While holding the end of the gun push the lance in and screw the lance clockwise to tighten.

PIC. 2

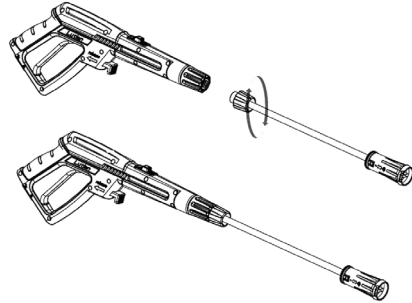

PUSH IN AND SCREW TOGETHER

HOLDERS PIC. 3

GUN HOLDER

To fit slide down onto the long lug

POWER CORD HOLDER

To fit slide down onto the lug and push down till it locks in place

LANCE SUPPORT

Position lance support and secure with the 2 screws

HOSE REEL HANDLE

The hose reel handle is already fitted. Locate the handle behind the reel and push through till it locks into place, ready for use.

PIC. 3

**GUN
HOLDER**

**POWER
CORD
HOLDER**

LANCE SUPPORT

PRESSURE HOSE TO GUN CONNECTION

PIC. 4

To connect hose;

Push the hose fitting in until it clicks into place. Hose fitting should be locked in place.

To disconnect hose;

Push hose lever in towards the gun and pull the hose fitting out and release the hose lever. Hose is now loose and able to be wound up for storage.

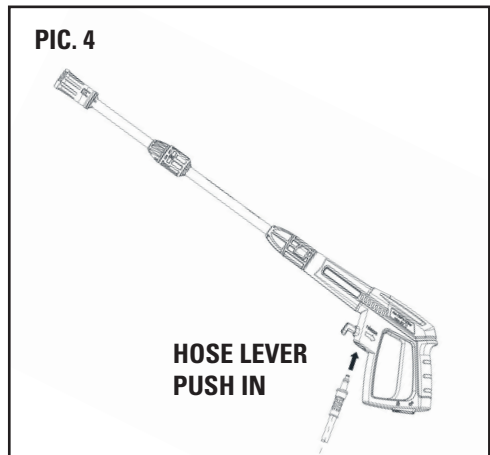

GARDEN CONNECTION

PIC. 5

Screw clear garden hose/filter connection to pump

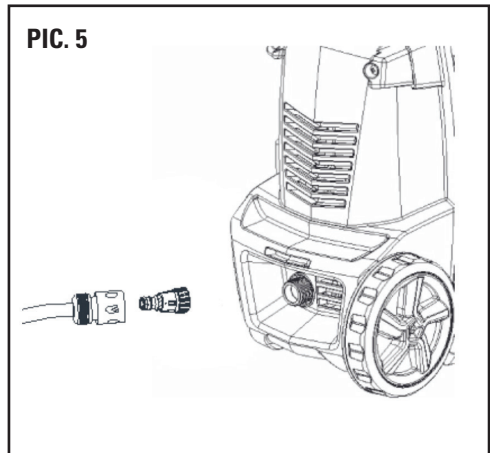

OPERATING INSTRUCTIONS

WARNING: THIS UNIT IS INTENDED TO BE USED WITH COLD WATER ONLY! DO NOT USE HOT WATER IN THIS PRESSURE CLEANER!

STARTING AND STOPPING YOUR PRESSURE CLEANER

Never switch your pressure cleaner ON unless the water has been turned on and connected to the pressure cleaner first.

Your pressure cleaner is equipped with an automatic on/off switch. The pressure cleaner will only run when the power switch is in the ON position and the trigger on the gun is squeezed, with water flowing through. When you release the trigger to stop spraying water through the gun, the motor will automatically shut off. Simply squeeze the trigger again to resume using the cleaner. Always ensure that you plug your pressure cleaner into a standard 240V AC power point.

OPERATING SWITCH

To turn your pressure cleaner ON, rotate the switch to 'ON/I'.

To turn your pressure cleaner OFF, push the switch to 'OFF/O'.

GUN SAFETY LOCK (PIC. 6)

This pressure cleaner is equipped with a gun trigger safety lock. When not using the pressure cleaner, use the safety lock to keep from accidentally engaging the high pressure spray.

BLEEDING THE PRESSURE WASHER SYSTEM

It is very important to bleed the gun before using the pressure cleaner.

To bleed the gun, simply connect the garden hose to the pressure cleaner and squeeze the trigger BEFORE turning the electrical supply on. This allows any air trapped inside the pressure cleaner and gun to be removed before using the unit. Continue holding trigger for approximately one minute to allow any excess air out of the unit. Water will flow through the gun at low pressure during this procedure.

TO START USING

1. Ensure your pressure washer is fully assembled, including the lance and nozzle.
2. Ensure the high pressure hose is firmly connected to the units outlet.
3. Connect your water hose to the pressure cleaner inlet.
4. Connect your water hose to the mains tap and turn on.
5. Un-lock the safety gun lock.
6. Bleed the pressure washer system.
7. Connect your pressure cleaner to a 240V AC power outlet and turn on.
8. Switch pressure cleaner ON.
9. Pick up gun, point at object to be cleaned and squeeze trigger.

NOTE: The unit should be turned completely OFF while not in use or while unattended.

GUN ROTATION PIC, 7

To ensure user comfort and ideal cleaning angle this model allows for the gun to rotate independent of the fitted nozzle.

To rotate the gun;

1. Release trigger to stop water flow.
2. Rotate the nozzle to the desired position.
3. Squeeze trigger to start using pressure washer again.

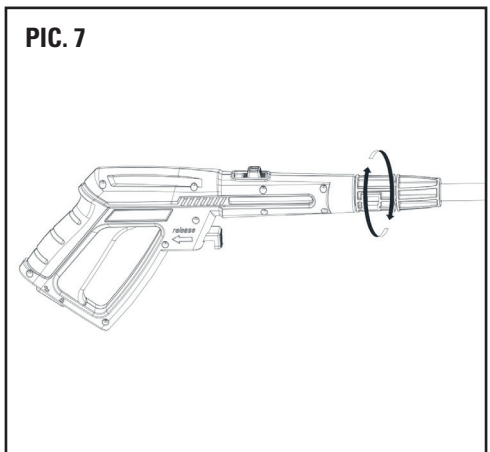
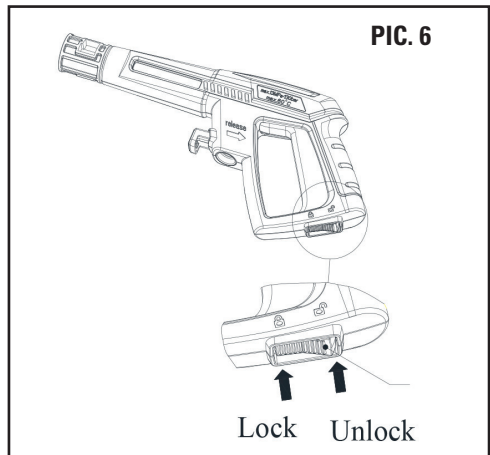

DETERGENT

This pressure washer comes with a built-in detergent bottle and variable detergent rate control. The detergent rate control is located below the ON/OFF switch while the detergent bottle is located on the rear of the pressure washer body. Only fill the detergent bottle with detergent only. Do not put any water into the container. The pressure cleaner will mix water and detergent automatically. Only use a biodegradable detergent as this will not clog the detergent bottle/nozzle.

This pressure washer is fitted with a variable detergent control, see Pic. 8. This is located below the ON/OFF switch.

Twisting this variable detergent control, see Pic. 8, clockwise you increase the amount of detergent used.

Twisting this variable detergent control, see Pic. 8, anti-clockwise you decrease the amount of detergent used.

PIC. 8

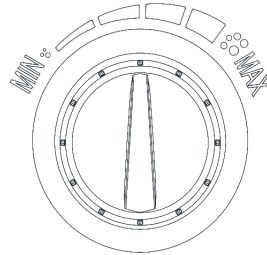

OPERATING

- 1 Ensure your pressure washer is fully.
- 2 Ensure the high pressure hose is firmly connected to the gun.
- 3 Connect your water hose to the pressure cleaner inlet
- 4 Connect your water hose to the mains tap and turn on
- 5 Un-lock the safety gun lock
- 6 Bleed the pressure washer system.
- 7 Connect your pressure cleaner to a 240V AC power outlet and turn on
- 8 Switch pressure cleaner ON
- 9 Pick up gun, point at object to be cleaned and squeeze trigger

NOTE: The unit should be turned completely OFF while not in use or while unattended.

To stop using;

- 1 Release the trigger and switch the unit to the OFF position.
- 2 Turn the main water tap OFF.
- 3 Squeeze the trigger to release the water pressure.
- 4 Engage the safety gun lock
- 5 Disconnect the water hose and pack up your pressure washer.
- 6 Once cool, about 1hr, wipe your pressure washer down and store in a secure location.

NOZZLES

Your pressure washer is supplied with these nozzles;

ADJUSTABLE NOZZLE PIC. 9

This nozzle can be adjusted while in use there is no need to stop the water flow.

Being an adjustable nozzle, there are many different positions which will give a variety of different spray widths and water pressure.

WARNING: Never point or spray water at people or animals, injury will occur.

WARNING: When adjusting the nozzle be careful of your hand as the injury may occur if the water spray touches your hand.

Low pressure and wide spray

- While holding the gun twist the nozzle to the left

High pressure and narrow spray

- While holding the gun twist the nozzle to the right

DETERGENT NOZZLE

Only use a biodegradable detergent as this will not clog the detergent bottle/nozzle. When finished using the detergent ensure that you have cleaned the detergent bottle/nozzle with clean water before storing.

- 1 Turn pressure washer off.
- 2 Lift the lid and fill the bottle with your desired detergent. Ideally use a biodegradable detergent as this will not clog the detergent bottle/nozzle.
- 3 Clip the detergent lid back in place
- 4 Pull the nozzle outward this is the detergent setting.
- 5 Rotate the nozzle clockwise or anti-clockwise to adjust the spray pattern.
- 6 Turn pressure washer on and continue cleaning
- 7 If you need a greater amount of detergent rotate the variable control "Clockwise", see page 14 Pic. 8.
- 8 If you need a lesser amount of detergent rotate the variable control "Anti-Clockwise", see page 14 Pic. 8.
- 9 Return nozzle to high pressure setting by pulling nozzle back inwards.

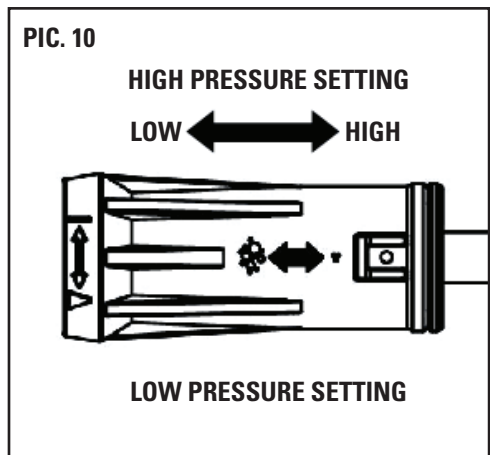
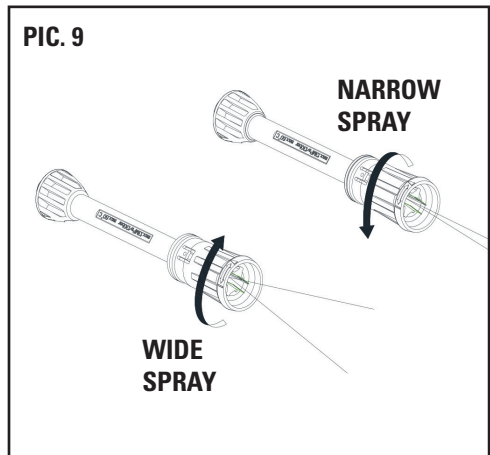

MAINTENANCE INFORMATION

It is recommended after every use or when required that following items are cleaned.

NOZZLE PIC. 11

When the nozzle is clogged, it will cause the pump to build pressure and may cause unit to surge, you can clean the nozzle inserting needle into the tip to rid of the deposits.

For the adjustable nozzle, you can also lubricate the nozzle collar (high pressure to low pressure) by using non-water soluble grease regularly.

INLET FILTER

The inlet filter may become blocked.

To check and clean:

- 1 Turn unit OFF and disconnect from mains power.
- 2 Turn water OFF.
- 3 Bleed off excess water and disconnect from mains water.
- 4 Unscrew and remove hose connector.
- 5 Remove white filter and check and clean.
- 6 Once clean replace white filter and re-fit the hose connector.
- 7 Turn Water on and bleed pressure washer
- 8 Turn pressure washer on and resume cleaning

CLEANING

NEVER use this pressure cleaner to clean itself. Damage caused by cleaning the pressure washer with its own gun will not be covered under warranty. Ensure pressure washer is cool before cleaning, about 1 hour after use.

To remove detergent bottle for cleaning;

1. Un-clip lid and remove detergent tube.
2. Pull out detergent bottle.
3. Pour excess detergent back into the original bottle.
4. Thoroughly rinse the bottle in clean water.
5. Push back into place, replace detergent tube and clip lid back on.

To finish cleaning pressure washer

- Wipe down all surfaces with a soft clean cloth.
- Rinse all nozzles in a bucket of clean water.
- Allow to dry before storing

PIC. 11

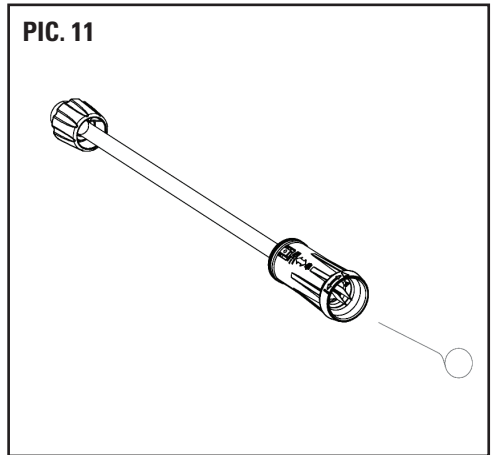

STORAGE

NOTE: When storing the pressure washer, parts, and accessories always store in a secure area with a temperature above 0° C.

Long-Term Storage

FOLLOW ALL OF THE NORMAL SHUT-DOWN PROCEDURES HOWEVER ADD THESE FOLLOWING STEPS....

- After disconnecting the water supply, and before disconnecting the high-pressure hose, turn the pressure cleaner on for 2-3 seconds, until any remaining water in the pump exits. TURN UNIT OFF IMMEDIATELY.

CONTINUED USE OF THE PRESSURE CLEANER WITHOUT WATER SUPPLY ATTACHED WILL CAUSE SEVERE DAMAGE TO THE UNIT!

CLEANING TIPS

RECOMMENDATIONS

If painted surfaces are peeling or chipping, use extreme caution as pressure washer may remove the loose paint from the surface. Note: Always pre-test any paint work in an inconspicuous area in case of paint damage.

DECK CLEANING - WITH OR WITHOUT DETERGENT

Pre-rinse deck and surrounding area with fresh water. If using deck wash, place deck wash into a bucket of cold water and apply with a brush and thoroughly clean area.

For best results, limit your work area to smaller sections of approximately 2m square, allow deck wash to remain on surface 1-3 minutes.

Do not allow deck wash to dry on surface, if surface appears to be drying, simply wet down surface with fresh water.

Rinse at high pressure in a long sweeping motion keeping the spray nozzle approximately 75mm to 150mm from the cleaning surface. Always clean from top to bottom and from left to right. For stubborn dirt/stains you can use the turbo nozzle. Be careful as the turbo nozzle may damage timber or some surfaces if held too close or too long on the area.

When moving on to a new section of the cleaning surface, be sure to overlap the previous section to eliminate stop marks and ensure a more even cleaning result.

HOUSE SIDING - WITH OR WITHOUT DETERGENT

Pre-rinse cleaning surface with fresh water. If using house wash, place house wash into a bucket of cold water and apply with a brush and thoroughly clean area. For best results apply house wash from bottom to top and limit your work area to smaller sections of approximately 2m square, allow house wash to remain on surface 1-3 minutes.

Do not allow house wash to dry on surface, if surface appears to be drying, simply wet down surface with fresh water.

Rinse at high pressure from top to bottom in an even sweeping motion keeping the spray nozzle approximately 150mm from the cleaning surface.

CEMENT PATIOS, BRICK & STONE - WITH OR WITHOUT DETERGENT

Pre-rinse cleaning surface with fresh water. If using all purpose cleaner, place all purpose cleaner into a bucket of cold water and apply with a brush and thoroughly clean area. For best results, limit your work area to smaller sections of approximately 2m². Allow all purpose cleaner to remain on surface 1-3 minutes.

Do not allow all purpose cleaner to dry on surface, if surface appears to be drying, simply wet down surface with fresh water.

Rinse at high pressure in a sweeping motion keeping the spray nozzle approximately 75mm to 150mm from the cleaning surface.

Always clean from top to bottom and from left to right. For stubborn dirt/stains you can use the turbo nozzle. Be careful as the turbo nozzle may damage timber or some surfaces if held too close or too long on the area.

CARS, BOATS & MOTORCYCLES - WITH OR WITHOUT DETERGENT

Pre-rinse vehicle with fresh water. If using vehicle wash, place vehicle wash into a bucket of cold water and apply with a soft sponge or cloth and thoroughly clean area. For best results, limit your work area to smaller sections of approximately 2m². Allow vehicle wash to remain on surface 1-3 minutes. For best results, clean one side of vehicle at a time and always apply vehicle wash from bottom to top, do not allow vehicle wash to dry on surface. Rinse at high pressure in a sweeping motion keeping the spray nozzle approximately 150mm to 200mm from the cleaning surface (distance should increase with pin-stripping, decals or other sensitive surfaces).

Always clean from top to bottom and from left to right. For best results, wipe surface dry with a chamois or soft dry cloth.

BBQ GRILLS, OUTDOOR POWER EQUIPMENT & GARDENING TOOLS - WITH OR WITHOUT DETERGENT

Pre-rinse surface with fresh water. If using all purpose cleaner, place all purpose cleaner into a bucket of cold water and apply with a brush and thoroughly clean area. For best results, limit your work area to smaller sections of approximately 2m². Allow all purpose cleaner to remain on surface 1-3 minutes.

Do not allow all purpose cleaner to dry on surface, if surface appears to be drying, simply wet down surface with fresh water.

Rinse at high pressure keeping the spray nozzle approximately 75mm to 150mm from the cleaning surface. For removing extremely stubborn dirt, it may be necessary to move the spray nozzle even closer to the surface for greater dirt cutting action or you can use the turbo nozzle. Be careful as the turbo nozzle may damage timber or some surfaces, including chipped paint if held too close or too long on the area. To remove caked-on mud from garbage cans, lawn mower blades, wheelbarrows or other non-sensitive metal surfaces.

PATIO & LAWN FURNITURE - WITH OR WITHOUT DETERGENT

Pre-rinse surface with fresh water. If using all purpose cleaner, place all purpose cleaner into a bucket of cold water and apply with a brush and thoroughly clean area. For best results, limit your work area to smaller sections of approximately 2m². Allow all purpose cleaner to remain on surface 1-3 minutes.

Do not allow all purpose cleaner to dry on surface, if surface appears to be drying, simply wet down surface with fresh water.

Rinse at high pressure keeping the spray nozzle approximately 75mm to 150mm from the cleaning surface. For stubborn dirt/stains you can use the turbo nozzle. Be careful as the turbo nozzle may damage timber or some surfaces, including chipped paint if held too close or too long on the area.

TROUBLE SHOOTING

WHEN THE SWITCH IS IN THE "I" POSITION THE MACHINE WILL NOT START	
Possible Cause	Suggested Fix
Electrical socket is faulty	Check plug, socket, fuses
Voltage is inadequate	Check that the voltage is adequate
Power cord is not plugged in	Plug in power cord
THE PUMP DOES NOT REACH ADEQUATE PRESSURE OR FLUCTUATES	
Water inlet filter is clogged	Remove and clean filter
Pump is drawing air	Tighten connections/bleed system
Nozzle could be in Detergent Mode	Pull nozzle back inwards to high pressure setting
Diameter of garden hose too small	Replace with 3/4 inch garden hose
Water supply is restricted	Check hose for kinks or leaks
Insufficient water supply	Fully open water source
THE PRESSURE CLEANER HAS OR WILL NOT MAINTAIN PRESSURE	
Excessive air in waterline and pump	Turn unit off
THE PRESSURE CLEANER MAKES EXCESSIVE NOISE	
Intake is blocked	Check the intake valves
Valves are worn, dirty, or clogged	Check, clean or replace valves
Filter is dirty	Check, clean, or replace filter

PARTS DIAGRAM

User replaceable parts listed below. All other parts must be serviced/replaced by an authorised service agent.

Part	Description	Part No.
1	Hose	84 EW2175H
2	Gun & Lance	84 EW2175GT
3	Gun Holder	84 EW2175GH
4	Lance Support	84 EW2175N
5	Power Cord Holder	84 EW2175PCH
6	Hose Holder and Handle	84 EW2175HR



For any queries or assistance call



Customer Service

AUST. 1300 660 457

NZ 0800 474 876

Hours of operation:

Monday to Friday 8.00am - 5.00pm AEST

Do not return to place of purchase.

Keep your purchase receipt, this will be required to make any claims under the 24 month warranty.

STANLEY **STANLEY**

STANLEY®, The STANLEY Logo, The Notched Rectangle and the Yellow and Black Diagonal Package Design are all trademarks of the Stanley Black & Decker, Inc or an affiliate thereof and are used under license. Product manufactured and distributed by Smart Marketing Group Pty Ltd. Manufactured in China.