

EMS6008-C

FOTILE RANGE HOOD



Specification

Product Size(W*D*H)(mm):	595 x 522 x (566-905)
Control:	Touch&wave
Odour reduction rate(%)	99
IEC Air Flow(m ³ /h):	1090
Gear:	3+T
Noise Level(dB):	Max: 57 Min: 39
Max Static Pressure(Pa):	900
LED Light Power(W):	LED 3Wx2
Minimum installation height(mm):	Distance between hob and range hood: 650

IEC 61591: International standard for air volume testing

Unit: mm

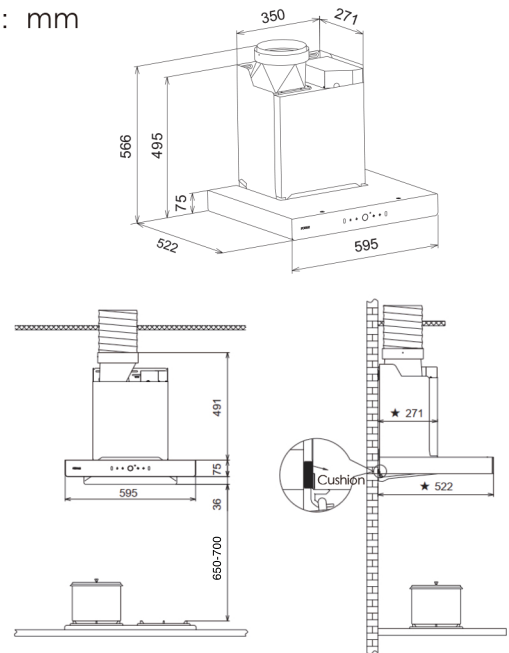

Wing-like Surround Suction Plate

Surround suction achieves complete coverage



Wave to Control

No need to touch, just wave



All-in-one Grease Cup

Can be put into the dishwasher



BLDC Motor

Low noise, powerful extraction

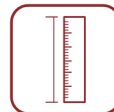

60CM Prefert Size

Simplified Installation

Warranty

Two year On-Site Warranty (including parts and labour); motor (all models) and adjustable elevation rods are covered by a ten-year (parts only) warranty.