

## EMG9008-C

FOTILE RANGE HOOD



With Decorative Cover

### Specification

Product Size(W*D*H)(mm):	895 x 522 x (566-905)
Voltage/frequency:	220-240V 50Hz
Motor Power(W):	294W
IEC Air Flow(m <sup>3</sup> /h):	1180
Gear:	Boost+3
Noise Level(dB):	High: 56 Low: 39
Max Static Pressure(Pa):	900
LED Light Power(W):	3Wx2
Minimum installation height(mm):	Distance between hob and range hood: 650

IEC 61591: International standard for air volume testing

Unit: mm

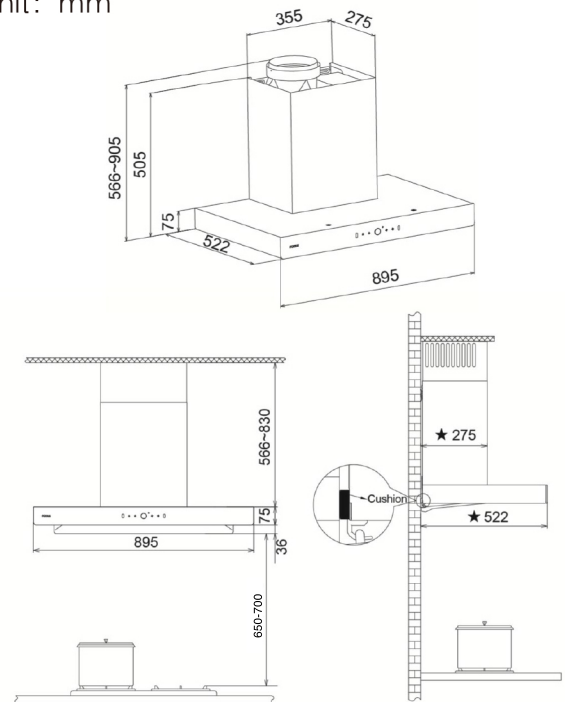

#### Wing-like Surround Suction Plate

Surround suction extraction achieves complete coverage



#### BLDC Motor

Low noise, powerful extraction



#### Wave to Control

No need to touch, just wave



#### Seamless installation

Integrated forming process, perfect match cabinets

### Warranty

Two year On-Site Warranty (including parts and labour); motor (all models) and adjustable elevation rods are covered by a ten-year (parts only) warranty.